

Precision Indexing (IN)

Full catalogue 2024

11/21/2024

 **IPT Kereskedelmi Kft.**
Ipar, ProfiL, Technika

Mazur Péter

IPT Kereskedelmi Kft.

Házgyári út 7.

Veszprém 8200

Magyarország

+36705583201

mazur.peter@iptker.hu

iptker.hu

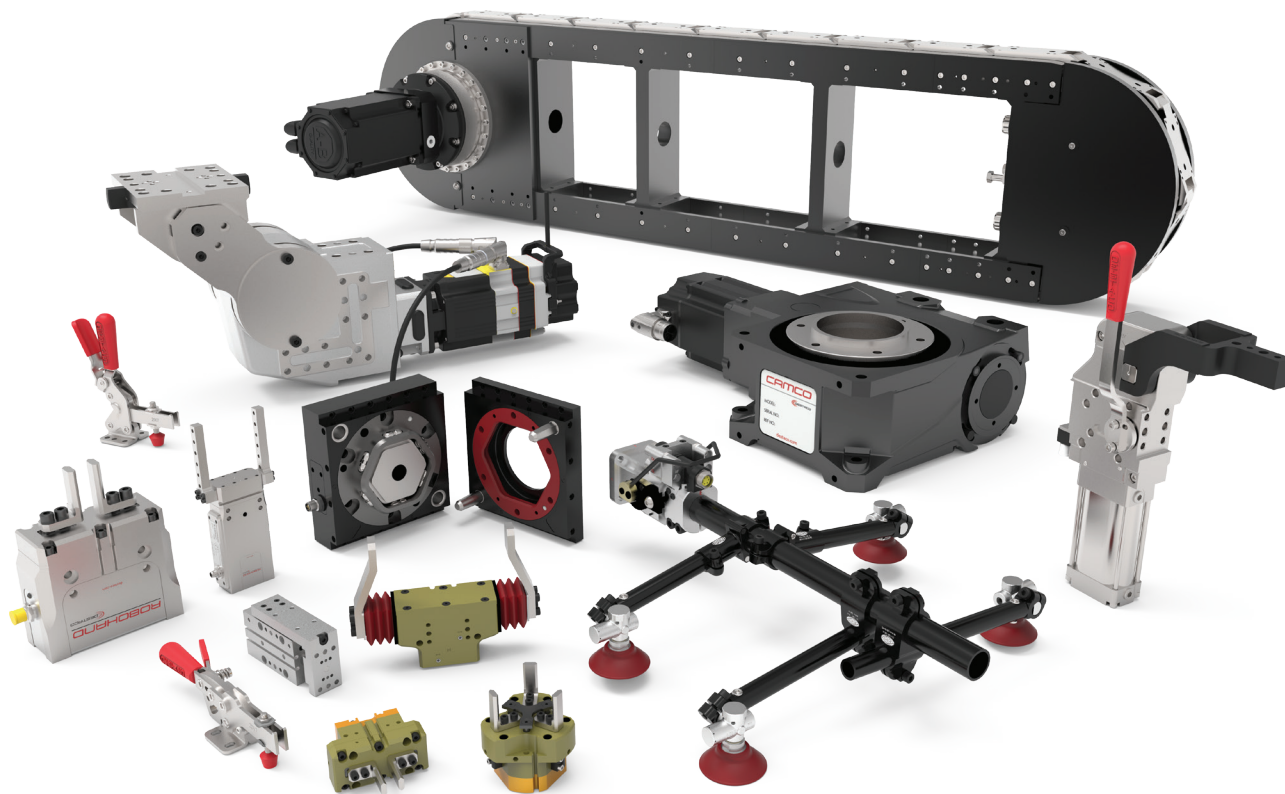

Precision Indexing (IN)

11/21/2024

This catalog is a custom document and the products included is based on your unique selection from portions of complete catalogs that already exist. Please refer to our full catalogs for more information on products not included in this customized document.

Table of Contents

GTB Roller Gear Servo Positioner	IN-SRV-1
PGM Parallel Gear Servo Positioner	IN-SRV-19
RSD Servo Indexers	IN-SRV-25
RDM Dial Indexers	IN-MCH-1
RD HD Dial Indexers	IN-MCH-41
E-Series HD Drives	IN-MCH-53
RA Right Angle Drives	IN-MCH-65
RGS/RGD Shaft/Flange Drives	IN-MCH-75
Parallel Shaft/Flange Drives	IN-MCH-95
RNG Easy Access Dial Indexers	IN-MCH-107
Overload Clutches	IN-CLU-1
Custom Cams	IN-CAM-1
Rite-Link Conveyors	IN-CNV-1
Table-Top Modular Conveyors	IN-CNV-3
Heavy Duty Modular Conveyors	IN-CNV-15
LPP Lineal Part Handles	IN-PRT-1
RPP Rotating Part Handlers	IN-PRT-7

Precision Indexing (IN)

11/21/2024

Table of Contents (continued)

GTB SERIES

Globoidal (Roller Gear) Servo Positioner | Table of Contents



Features:

Destaco's **CAMCO GTB Series** are lightweight, compact, high-accuracy programmable servo positioners.

The exceptional low profile high-torque output design supports the demands of high inertia load applications.

Available in four sizes, the GTB series units are lubricated for life and can be mounted in either horizontal or vertical orientations. The GTB Series feature the largest utility through hole diameter available for its size, making it ideal for space constrained machine applications.

Table of Contents

IN-SRV-#

Features & Benefits	2
How to Order	3
Specifications	5
Indexer Sizing	6
GTB40	7
GTB63	10
GTB80	13
GTB100	16

Zero Backlash Roller Gear Cam Mechanism

Innovative roller gear design provides exceptionally smooth motion performance. The globoidal cam and output turret with integrated rollers are a preloaded system that delivers zero backlash for superior accuracy, stiffness and long term durability.

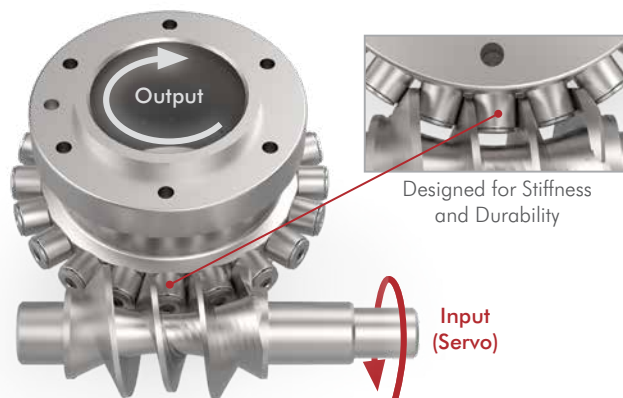

Flexible Drive Options

Each GTB model can be ordered in two different drive options. The high-torque gear drive option is used for applications with large inertia requirements while maintaining a small motor size. The direct drive option provides zero backlash, high precision operation. Both options interface with an array of servo motor suppliers.

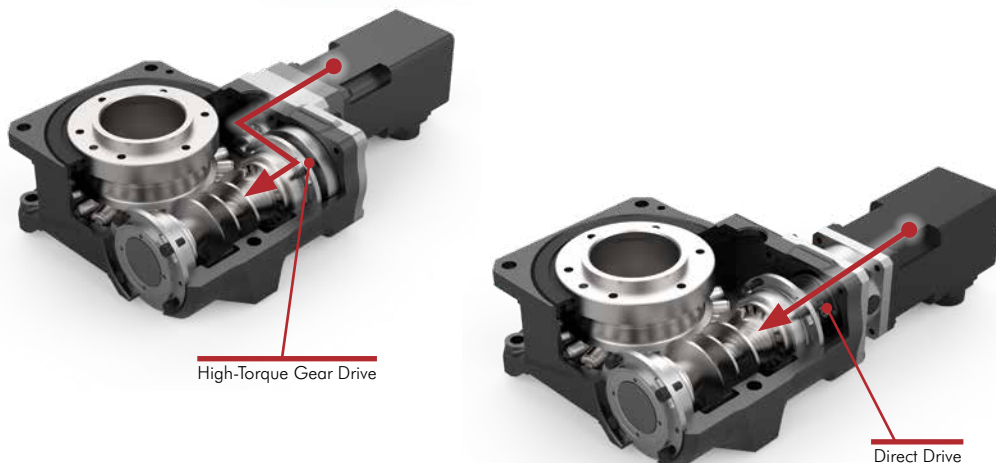

Orientation Independent Mounting

GTB Series units can be mounted in any orientation for easy installation and machine standardization.

Install units in any configuration:

- Flat horizontal table mounting
- Vertical mounting
- Trunnion Mounting
- Inverted (upside down) mounting



GTB SERIES

Globoidal (Roller Gear) Servo Positioner | How To Order

GTB Series: How To Order

Globoidal (Roller Gear) Servo Positioner Base Unit

GTB Series units can be interfaced with wide variety of servo motor manufacturers. Use the MI code tables to identify the supported motors for each GTB unit. The MI code specifies the motor adapter plate that provides direct easy motor mounting to the GTB servo positioner.

The -H option for independent mounting orientation comes standard with every GTB series unit. The -T option for precision dial plate locating dowel hole and -B option for precision mounting dowel holes are also provided as standard.



GTB Series without motor installed

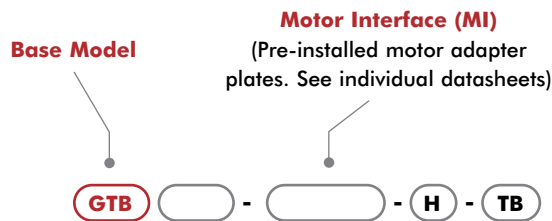

Size	Supported Gear Ratios
40	45:1
	15:1
63	60:1
	20:1
80	60:1
	20:1
100	60:1
	20:1

Standard Features

- H** Orientation independent mounting. Supports vertical, horizontal, trunnion applications
- T** Single output flange surface dowel hole for precision dial plate locating
- B** Precision placement housing dowel holes, 2 on top of unit, 2 on bottom of unit

Easily Integrates with a Variety of Servo Motor Manufacturers

Allen Bradley	Mitsubishi
AMK	Panasonic
Mitsubishi	Sanyo
FANUC	SEW
Keyence	Siemens
KUKA	Yaskawa

Units are available in two different gear ratios based on Direct or Geared motor coupling. Contact Sales to determine what motors are supported for precision direct drive applications and geared drive high torque configurations.



Gear Drive:
High Inertia Applications
45:1 GTB40
60:1 GTB63, GTB80, GTB100



Direct Drive:
Zero Backlash Precision Applications
15:1 GTB40
20:1 GTB63, GTB80, GTB100

GTB Series: How to Order configured System (Allen Bradley only)

Servo Positioner Configured Systems

GTB Series units can be interfaced with wide variety of servo motor manufacturers. Use the MI code table to identify the supported motors for each GTB unit.

GTB series are also offered as a configured system when selecting Allen Bradley servo motors. The Allen Bradley servo motor will be installed to the GTB unit and shipped as a complete assembly. The GTB series and motor combinations are a matched pair that supports a variety of servo positioning rotary table applications. To use one of the configured systems you must verify the application requirements are within the operating parameters of the GTB unit and motor combination.



GTB Series with Allen Bradley Motor Installed*

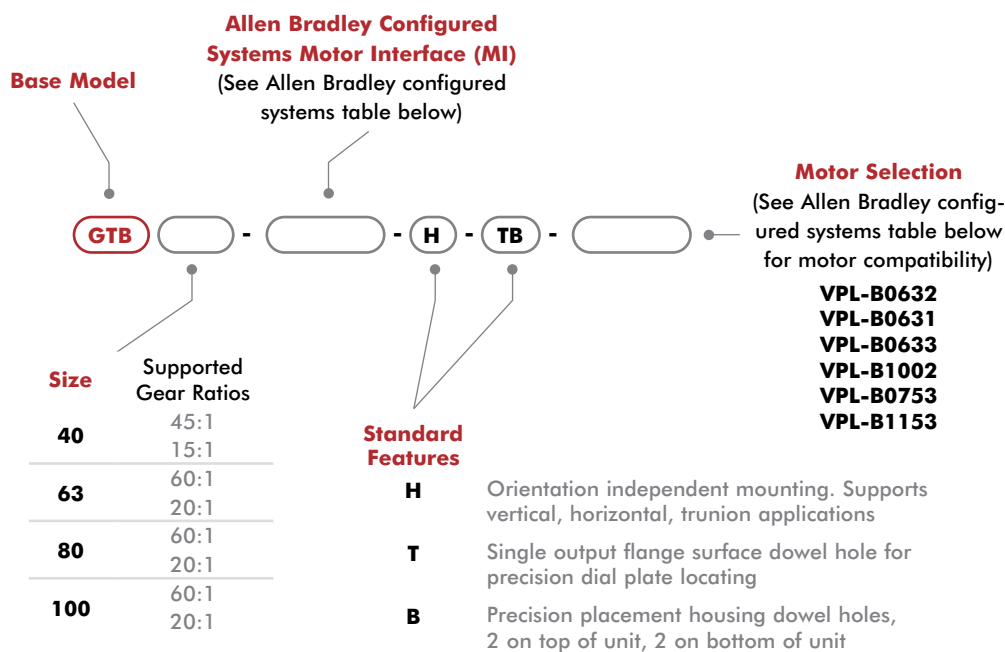

Allen Bradley Configured Systems

Size	Base Part #	Allen Bradley MI Code #	Motor Coupling	Gear Ratio	Motor Vendor	Allen Bradley Motor Part #	Motor Frame mm [in]	Flange size mm [in]	Shaft Ø mm [in]
40	GTB40	FDG20	Direct	15:1	Allen Bradley	VPL-B0632	60 [2.36]	63 [2.48]	9 [0.35]
	GTB40	FGC20	Geared	45:1		VPL-B0631			
63	GTB63	GDP20	Direct	20:1		VPL-B0633			
	GTB63	GGC22	Geared	60:1		VPL-B0632			
80	GTB80	HDP20	Direct	20:1		VPL-B1002	100 [3.94]	100 [3.94]	16 [0.63]
	GTB80	HGD24	Geared	60:1		VPL-B0753	80 [3.15]	75 [2.95]	11 [0.43]
100	GTB100	JDG20	Direct	20:1		VPL-B1153	100 [3.94]	115 [4.53]	19 [0.75]
	GTB100	JGE27	Geared	60:1					

* = Servo Positioner units are assembled, tested and shipped with the above recommended motor for best performance.

GTB SERIES

Globoidal (Roller Gear) Servo Positioner | Specifications

High Torque Gear Drive: High Inertia Application

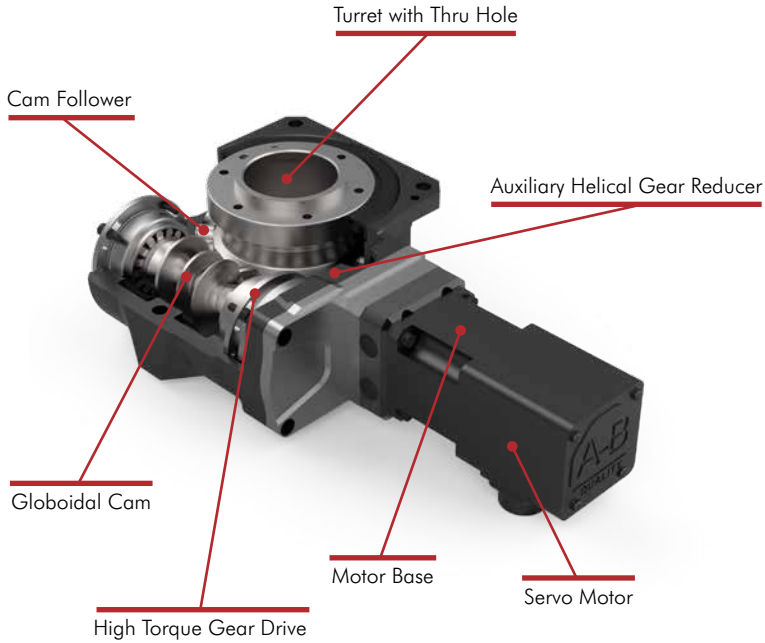

Direct Drive: Zero Backlash Precision Applications

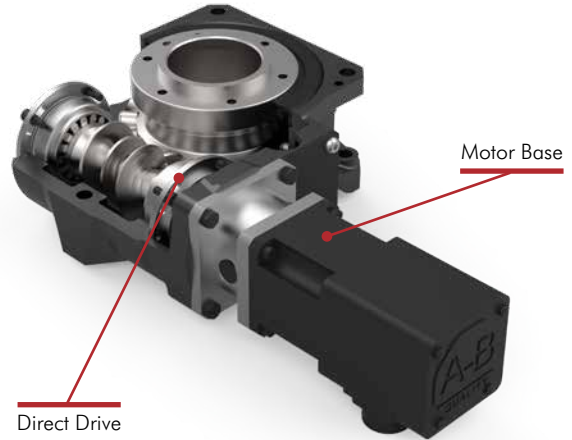

NOTE:

Motor brake must be applied for applications with gravity torque acting on output table (trunnion mounting) in the case of power loss. Follow the instruction manual for fitting and installing motor. Improper handling can cause damage or product malfunction.

General Specifications	Symbol	Units	GTB40		GTB63		GTB80		GTB100	
			Direct	Geared	Direct	Geared	Direct	Geared	Direct	Geared
Motor Coupling			Direct	Geared	Direct	Geared	Direct	Geared	Direct	Geared
Constant lead ratio			15:1	45:1	20:1	60:1	20:1	60:1	20:1	60:1
Center distance		mm [in]	40 [1.57]		63 [2.48]		80 [3.15]		100 [3.94]	
Through hole diameter	Ø	mm [in]	25 [0.98]		50 [1.97]		75 [2.95]		85 [3.35]	
Accuracy		arc-sec	90 ±45		60 ±30		40 ±20		40 ±20	
Repeatability		arc-sec	20 ±10		14 ±7		10 ±5		10 ±5	
Allowable static torque	T _s	N-m [in-lb]	176 [1558]		411 [3637]		600 [5310]		1341 [11868]	
Max start / stop torque	T _U	N-m [in-lb]	94 [832]		210 [1859]		307 [2717]		880 [7789]	
Allow. mean output speed	N _m	rpm	86		55		50		45	
Allow. ultimate output speed	N _U	rpm	100		70		60		50	
Allow. axial cap. on output	P _a	N [lbs]	1100 [247]		1850 [416]		3632 [816]		4100 [922]	
Allow. radial cap. on output	P _r	N [lbs]	740 [166]		1500 [337]		3100 [697]		3420 [769]	
Allow. moment cap. on output	P _{moment}	N-m [in-lb]	40 [354]		85 [752]		226 [2000]		313 [2770]	
Inertia moment on input axis	J	[lb-ft ²] x 10 ⁻⁴ [kg-m ²] x 10 ⁻⁴	[6.24] 0.263	[4.03] 0.17	[20.67] 0.871	[9.49] 0.4	[76.27] 3.214	[36.07] 1.52	[246.55] 10.39	[96.82] 4.08
Backlash		arc-sec	0	25	0	15	0	15	0	10
Average efficiency		%	90	80	90	80	90	80	90	80
Lubrication (Maint. Free)			Grease		Grease		Grease		Grease	
Weight		[lbm] kg	[7.28] 3.3	[7.72] 3.5	[13.01] 5.9	[13.67] 6.2	[28.44] 12.9	[31.09] 14.1	[53.58] 24.3	[55.57] 25.2

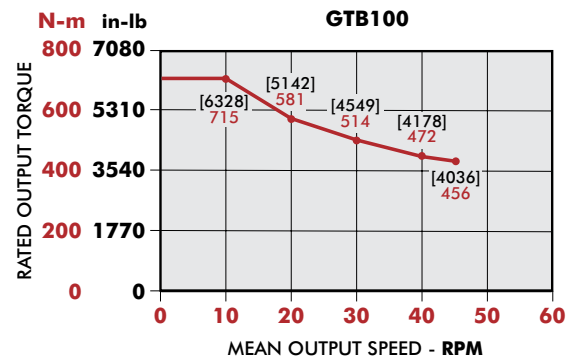
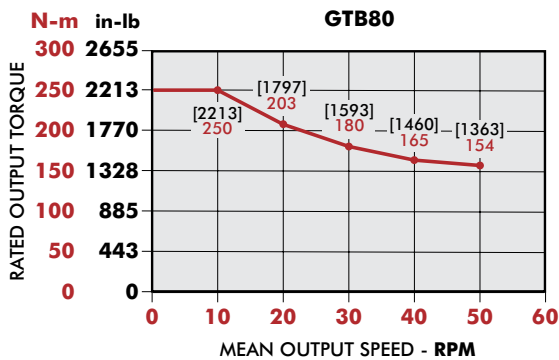
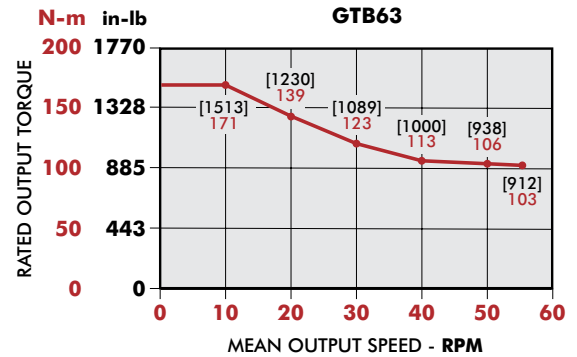
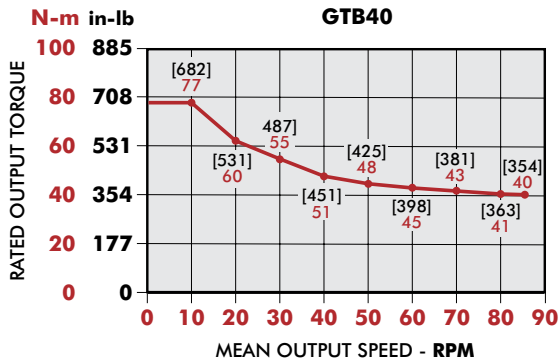

Sizing GTB Series for an Application (Contact Destaco for sizing application support)

1. Load diagram

Check motion profile and resultant inertia torque.
(Add working torque if applied).

Start and stop speed can be simplified to average speed within a segment.

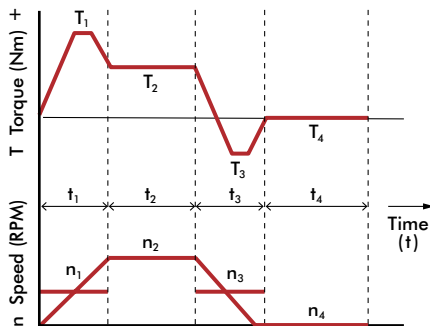

2. Check key conditions

$$\text{Mean torque } T_{mean} = \frac{10}{3} \sqrt{\frac{n_1 \cdot t_1 \cdot |T_1|^{\frac{10}{3}} + n_2 \cdot t_2 \cdot |T_2|^{\frac{10}{3}} + \dots + n_n \cdot t_n \cdot |T_n|^{\frac{10}{3}}}{n_1 \cdot t_1 + n_2 \cdot t_2 + \dots + n_n \cdot t_n}} \quad (\text{N-m})$$

$$\text{Mean output speed } n_{mean} = \frac{n_1 \cdot t_1 + n_2 \cdot t_2 + \dots + n_n \cdot t_n}{t_1 + t_2 + \dots + t_n} \quad (\text{rpm})$$

$$\text{Max output speed } n_{max} \quad (\text{rpm})$$

3. Pre-selection

Choose a size that meets these criteria.

$$T_{mean} < \text{Maximum rated output torque (N-m)}$$

$$n_{mean} < \text{Allowable mean output speed Nm (rpm)}$$

$$n_{max} < \text{Allowable ultimate output speed Nu (rpm)}$$

4. Check specifications

Start/stop torque $T_1 < \text{Maximum rated output torque (N-m)}$
 $T_3 < \text{Maximum rated output torque (N-m)}$

Operation condition factor
 Smooth without any impact or sudden load $f = 1.0$
 Normal, but occasional emergency stop $f = 1.5$
 Operation with frequent impact or sudden load $f = 3.0$

$$\text{Estimated lifetime } L_h = 12000 \left(\frac{T_{op}}{f \cdot T_{mean}} \right)^{\frac{10}{3}} \quad (\text{hours})$$

5. Selection complete

If above values don't satisfy requirements, go back to step 2 and 3 to re-select size.

GTB40 SERIES

Globoidal (Roller Gear) Servo Positioner | Dimensions

GTB40-FG (Motor Frame Size □ = 38 [1.50], 40 [1.57])

Gear Drive: High Inertia Applications: Ratio 45:1

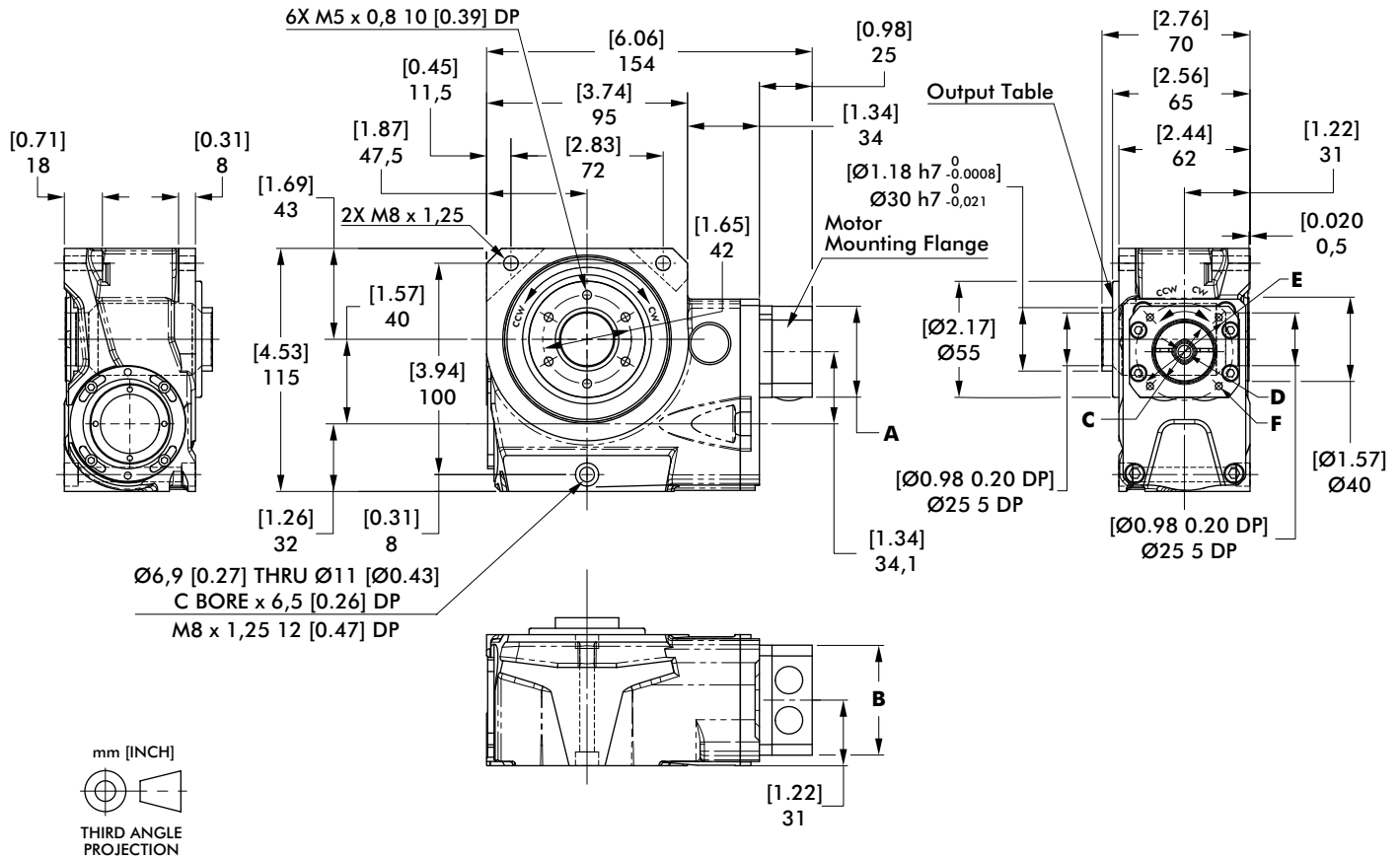

Input/Output Rotation: CW/CCW

MI CODE	A Width mm [in]	B Height mm [in]	C Pilot Ø x Depth mm [in]	D Shaft Ø mm [in]	E Fixing Holes PCD mm [in]	F Fixing Holes Qty x Size mm [in]
FGA20	43 [1.69]	52 [2.05]	Ø30 [1.18] x 4 [0.16]	8 [0.31]	46 [1.81]	4X M4 x 11,5 [0.45] DEEP
FGB20	43 [1.69]	52 [2.05]	Ø30 [1.18] x 4 [0.16]	8 [0.31]	45 [1.77]	4X M3 x 8,5 [0.33] DEEP
FGC20	55 [2.17]	55 [2.17]	Ø40 [1.57] x 3 [0.12]	9 [0.35]	63 [2.48]	4X M5 X 14 [0.55] DEEP
FGD20	55 [2.17]	55 [2.17]	Ø40 [1.57] x 3 [0.12]	9 [0.35]	63 [2.48]	4X M4 X 11,5 [0.45] DEEP

GTB40 SERIES

Globoidal (Roller Gear) Servo Positioner | Dimensions

GTB40-FD (Motor Frame Size □ = 60 [2.37])

Direct Drive: Zero Backlash Precision Applications: Ratio 15:1

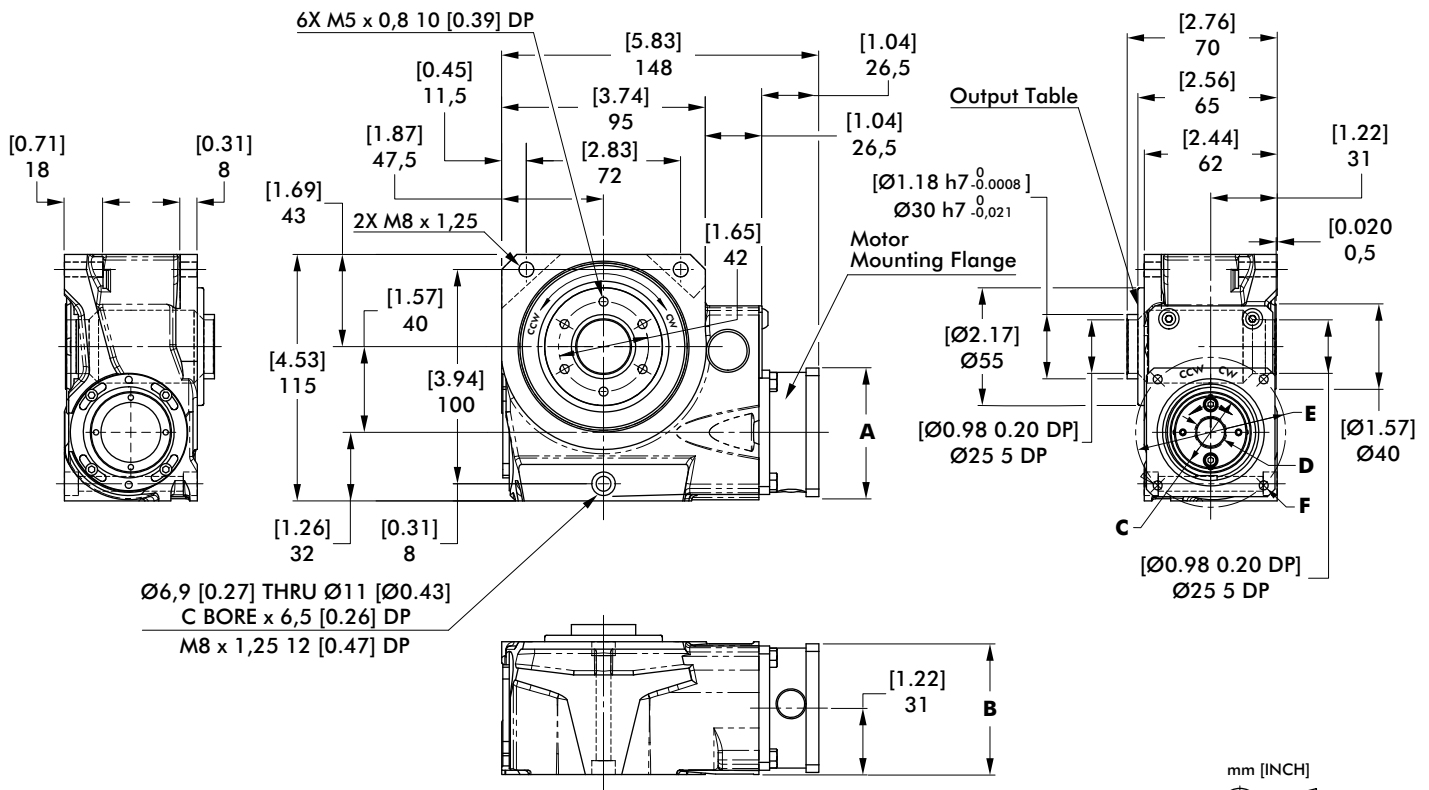

Input/Output Rotation: CW/CCW

MI CODE	A Width mm [in]	B Height mm [in]	C Pilot Ø x Depth mm [in]	D Shaft Ø mm [in]	E Fixing Holes PCD mm [in]	F Fixing Holes Qty x Size mm [in]
FDA20	60 [2.36]	60 [2.36]	Ø50 [1.97] x 4 [0.16]	Ø14 [0.55]	Ø70 [2.76]	4X M5 THRU
FDB20				Ø11 [0.43]		
FDC20				Ø14 [0.55]		
FDD20				Ø9 [0.35]		
FDE20				Ø12 [0.47]		
FDG20	55 [2.17]	55 [2.17]	Ø40 [1.57] x 4 [0.16]	Ø9 [0.35]	Ø63 [2.48]	4X M5 THRU
FDH20	70 [2.76]	70 [2.76]	Ø60 [2.36] x 2,5 [0.10]	Ø11 [0.43]	Ø75 [2.95]	4X M5 THRU
FDJ20	55 [2.17]	55 [2.17]	Ø40 [1.57] x 4 [0.16]	Ø9 [0.35]	Ø63 [2.48]	4X M4 THRU
FDK20	90 [3.54]	90 [3.54]	Ø80 [3.15] X 4 [0.16]	Ø16 [0.63]	Ø100 [3.94]	4X M6 THRU

GTB40 SERIES

Globoidal (Roller Gear) Servo Positioner | Dimensions

GTB40 Option Specifications

Dowel Hole Option -B, Housing -T: Output Table

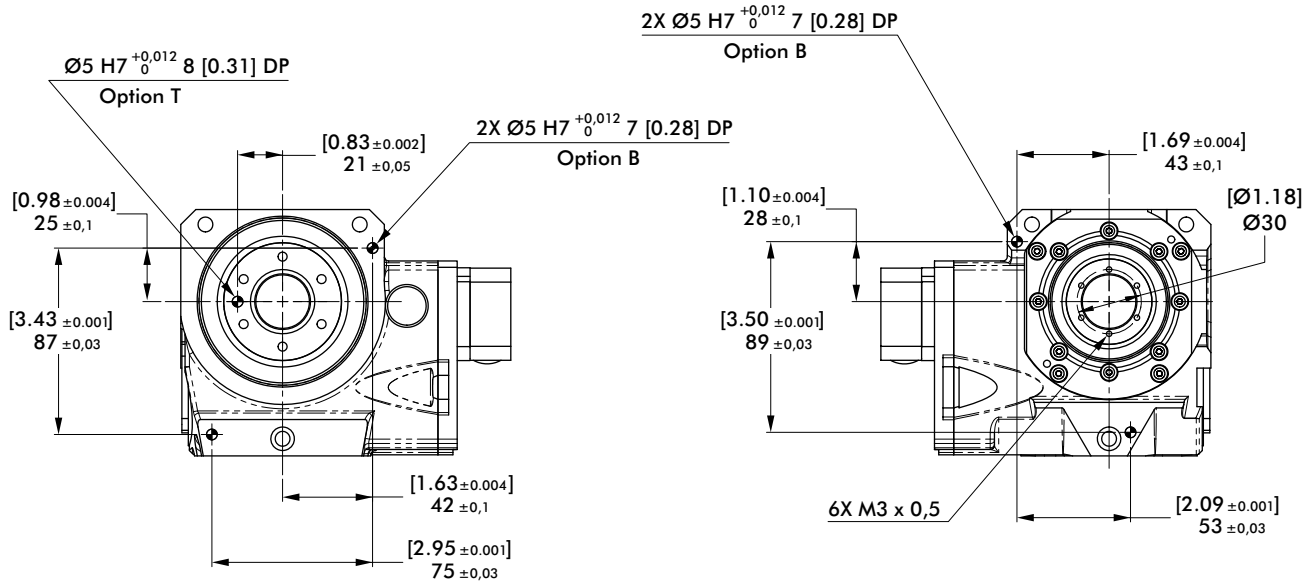

GTB63 SERIES

Globoidal (Roller Gear) Servo Positioner | Dimensions

GTB-63-GG (Motor Frame Size □ = 60 [2.37])

Gear Drive: High Inertia applications: Ratio 60:1

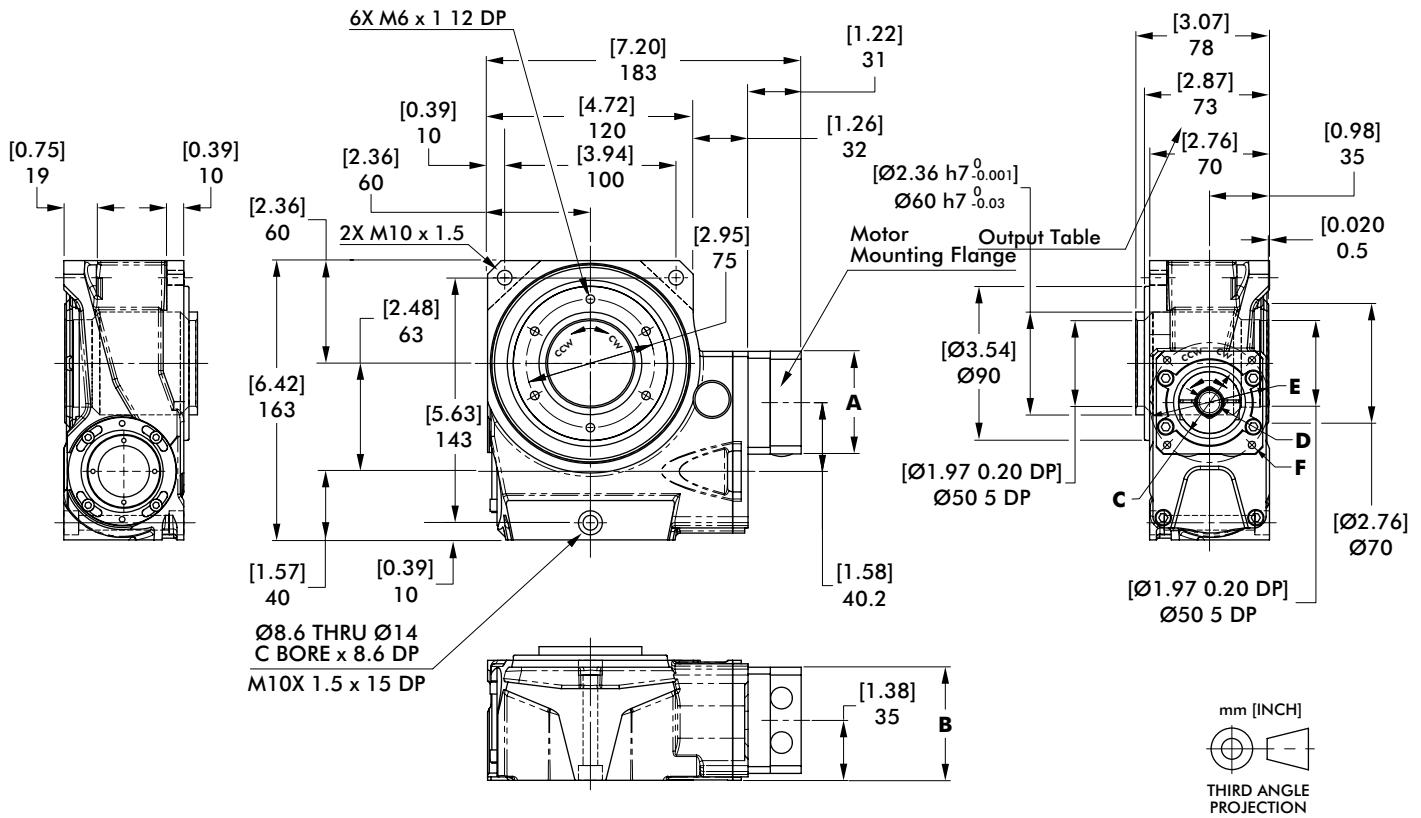

Input/Output Rotation: CW/CCW

MI CODE	A Width mm [in]	B Height mm [in]	C Pilot Ø x Depth mm [in]	D Shaft Ø mm [in]	E Fixing Holes PCD mm [in]	F Fixing Holes Qty x Size mm [in]
GGA20	60 [2.36]	62 [2.44]	Ø50 [1.97] x 5 [0.20]	Ø14 [0.55]	Ø70 [2.76]	4X M5 x 14 [0.55] Deep
GGA22				Ø9 [0.35]		
GGB20				Ø14 [0.55]		
GGB21				Ø11 [0.43]		
GGC22	70 [2.76]	70 [2.76]	Ø40 [1.57] x 3 [0.12]	Ø9 [0.35]	Ø63 [2.48]	4X M5 x 14 [0.55] Deep
GGD23				Ø12 [0.47]	Ø70 [2.76]	
GGE24				Ø11 [0.43]	Ø75 [2.95]	
GGF22	60 [2.36]	62 [2.44]	Ø40 [1.57] x 3 [0.12]	Ø9 [0.35]	Ø63 [2.48]	4X M4 x 11,5 [0.45] Deep
GGG20	70 [2.76]	70 [2.76]	Ø60 [2.36] x 5 [0.20]	Ø14 [0.55]	Ø75 [2.95]	4X M6 x 16 [0.63] Deep

GTB63 SERIES

Globoidal (Roller Gear) Servo Positioner | Dimensions

GTB63-GD (Motor Frame Size □ = 60 [2.36], 80 [3.15], 86 [3.39], 90 [3.54])

Direct Drive: Ratio 20:1

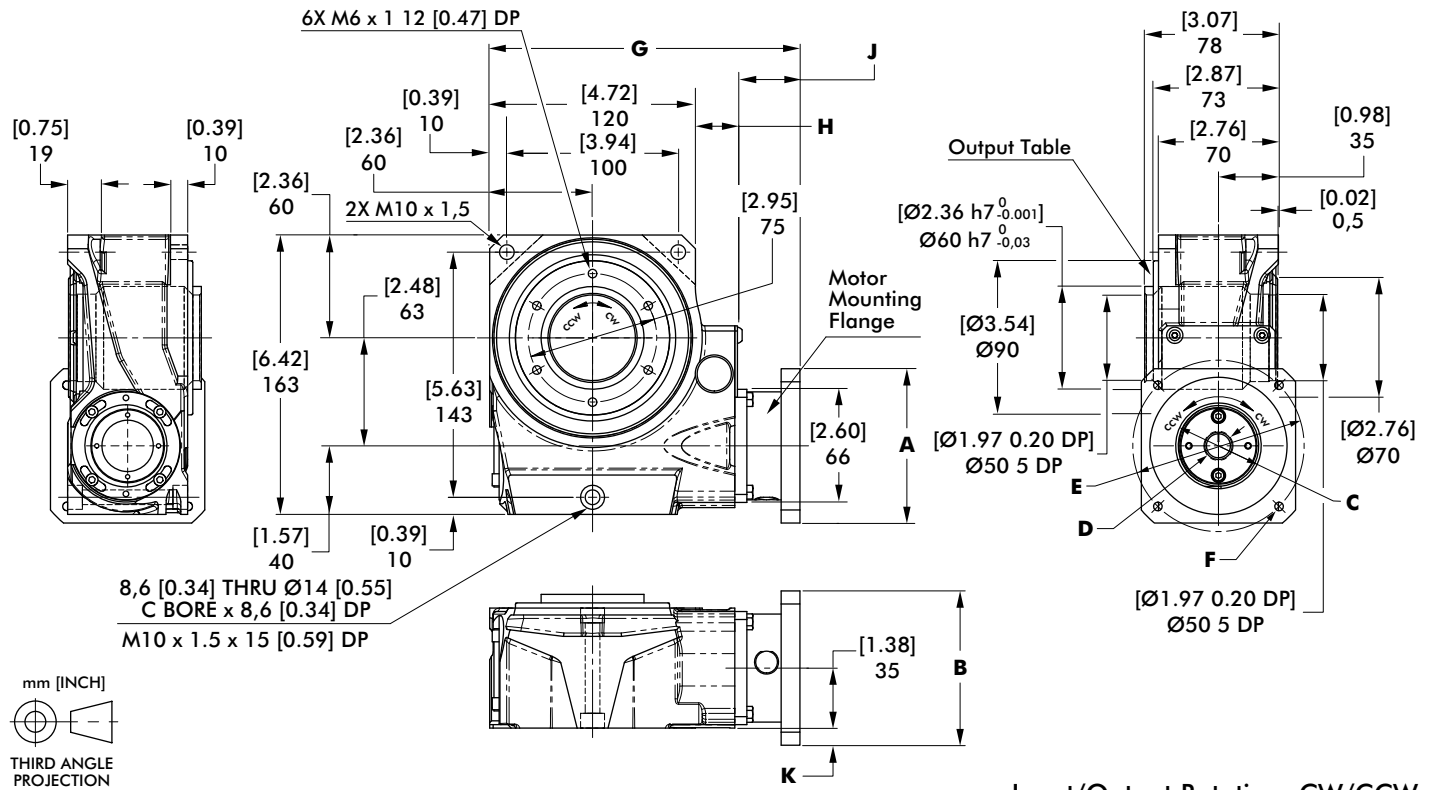

MI CODE	A Width mm [in]	B Height mm [in]	C Pilot Ø x Depth mm [in]	D Shaft Ø mm [in]	E Fixing Holes PCD mm [in]	F Fixing Holes Qty x Size mm [in]
GDA20	60 [2.36]	60 [2.36]	Ø50 [1.97] x 4 [0.16]	Ø14 [0.55]	Ø70 [2.76]	4X M5 THRU
GDB20	80 [3.15]	80 [3.15]	Ø70 [2.76] x 4 [0.16]	Ø19 [0.75]	Ø90 [3.54]	
GDC20				Ø14 [0.55]		4X M6 THRU
GDD20	90 [3.54]	90 [3.54]	Ø80 [3.15] x 6 [0.24]	Ø16 [0.63]	Ø100 [3.94]	
GDE20						4X M6 THRU
GDF20	60 [2.36]	60 [2.36]	Ø50 [1.97] x 4 [0.16]	Ø14 [0.55]	Ø70 [2.76]	4X M4 THRU
GDG20				Ø19 [0.75]		4X M5 THRU
GDH20	80 [3.15]	80 [3.15]	Ø70 [2.76] x 4 [0.16]	Ø14 [0.55]	Ø90 [3.54]	
GDJ20				Ø16 [0.63]		4X M6 THRU
GDK20	90 [3.54]	90 [3.54]	Ø80 [3.15] x 6 [0.24]	Ø10 [0.39]	Ø100 [3.94]	
GDL20	60 [2.36]	60 [2.36]	Ø50 [1.97] x 4 [0.16]	Ø12 [0.47]	Ø70 [2.76]	4X M5 THRU
GDM20	80 [3.15]	80 [3.15]	Ø70 [2.76] x 4 [0.16]	Ø16 [0.63]	Ø90 [3.54]	4X M6 THRU
GDN20	72 [2.83]	72 [2.83]	Ø60 [2.36] x 4 [0.16]	Ø14 [0.55]	Ø75 [2.95]	
GDP20	55 [2.17]	55 [2.17]	Ø40 [1.57] x 5 [0.20]	Ø9 [0.35]	Ø63 [2.48]	
GDQ20						4X M5 THRU
GDR20	70 [2.76]	70 [2.76]	Ø60 [2.36] x 4 [0.16]	Ø11 [0.43]	Ø75 [2.95]	



Frame Size	G	H	J	K
60	178 [7.01]	24,5 [0.96]	33,5 [1.32]	--
80	180 [7.09]		35,5 [1.40]	5 [0.20]
86	181 [7.13]		36,5 [1.44]	10 [0.39]
90				

GTB63 SERIES

Globoidal (Roller Gear) Servo Positioner | Dimensions

GTB63 Option Specifications

Dowel Hole Option -B, Housing -T: Output Table

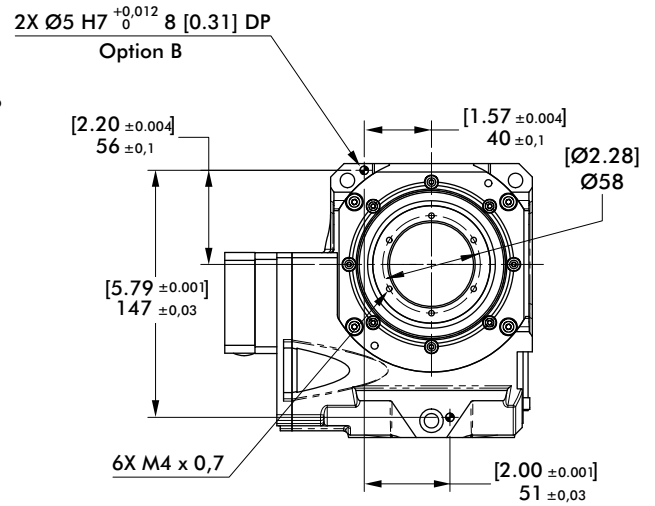
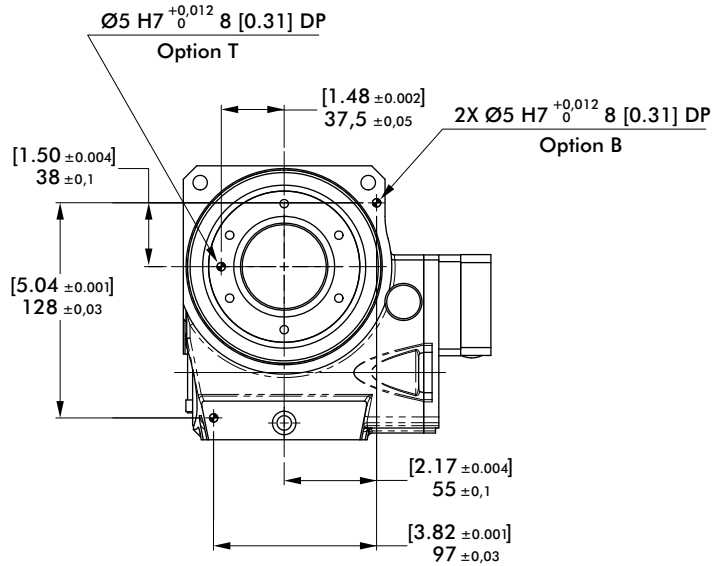

GTB80 SERIES

Globoidal (Roller Gear) Servo Positioner | Dimensions

GTB80-HG (Motor Frame Size □ = 80 [3.15], 86 [3.39], 90 [3.54])

Gear Drive: High Inertia Applications: Ratio 60:1

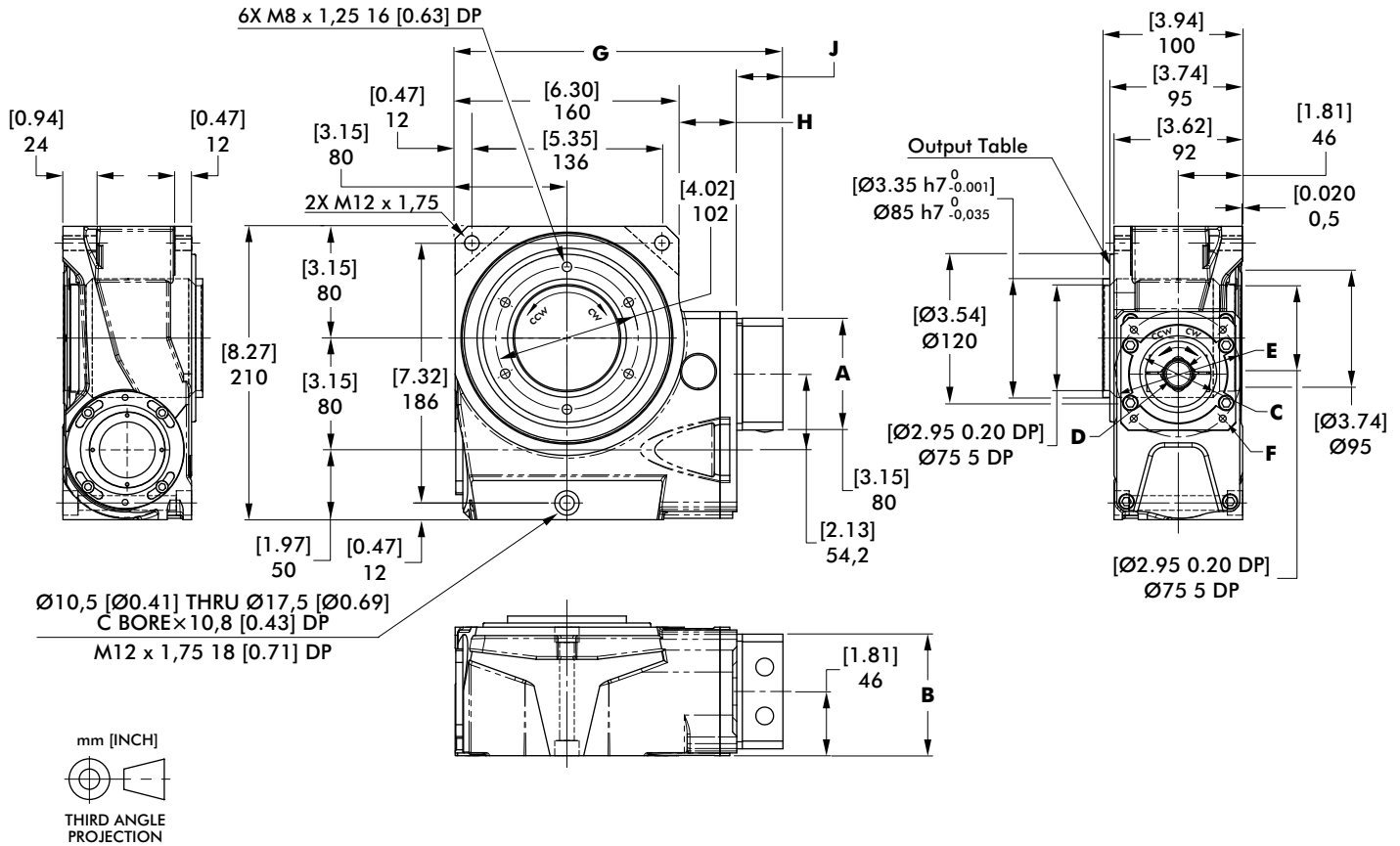

Input/Output Rotation: CW/CCW

MI CODE	A Width mm [in]	B Height mm [in]	C Pilot Ø x Depth mm [in]	D Shaft Ø mm [in]	E Fixing Holes PCD mm [in]	F Fixing Holes Qty x Size mm [in]
HGA20	80 [3.15]	82 [3.23]	Ø70 [2.76] x 4,5 [0.18]	Ø19 [0.75]	Ø90 [3.54]	4X M6 THRU
HGA22				Ø16 [0.63]		4X M6 x 17 [0.67] DEEP
HGB21	90 [3.54]	88 [3.46]	Ø80 [3.15] x 7 [0.28]	Ø14 [0.55]	Ø100 [3.94]	4X M6 THRU
HGB22				Ø16 [0.63]		4X M6 x 17 [0.67] DEEP
HGB23	80 [3.15]	82 [3.23]	Ø70 [2.76] x 4,5 [0.18]	Ø10 [0.39]	Ø75 [2.95]	4X M6 THRU
HGC20				Ø11 [0.43]		4X M5 x 14 [0.55] DEEP
HGD24	80 [3.15]	82 [3.23]	Ø60 [2.36] x 3 [0.12]	Ø16 [0.63]	Ø90 [3.54]	4X M6 THRU
HGE22				Ø14 [0.55]		
HGF25	90 [3.54]	88 [3.46]	Ø80 [3.15] x 4 [0.16]	Ø16 [0.63]	Ø100 [3.94]	4X M6 x 15 [0.59] DEEP
HGG26				Ø14 [0.55]		
HGG25	90 [3.54]	88 [3.46]	Ø80 [3.15] x 4 [0.16]	Ø16 [0.63]	Ø100 [3.94]	4X M6 x 15 [0.59] DEEP
HGG25				Ø14 [0.55]		
HGH20	98 [3.86]	98 [3.86]	Ø95 [3.74] x 4 [0.16]	Ø19 [0.75]	Ø115 [4.53]	4X M8 x 22,5 [0.89] DEEP



80



86/90

Frame Size	G	H	J
80	234 [9.21]	41,5 [1.63]	33 [1.30]
86	241 [9.49]	45,5 [1.79]	35,5 [1.40]
90			

GTB80 SERIES

Globoidal (Roller Gear) Servo Positioner | Dimensions

GTB80-HD (Motor Frame Size □ = 80 [3.15], 86 [3.39], 90 [3.54], 100 [3.94])

Direct Drive: Zero Backlash Precision Applications: Ratio 20:1

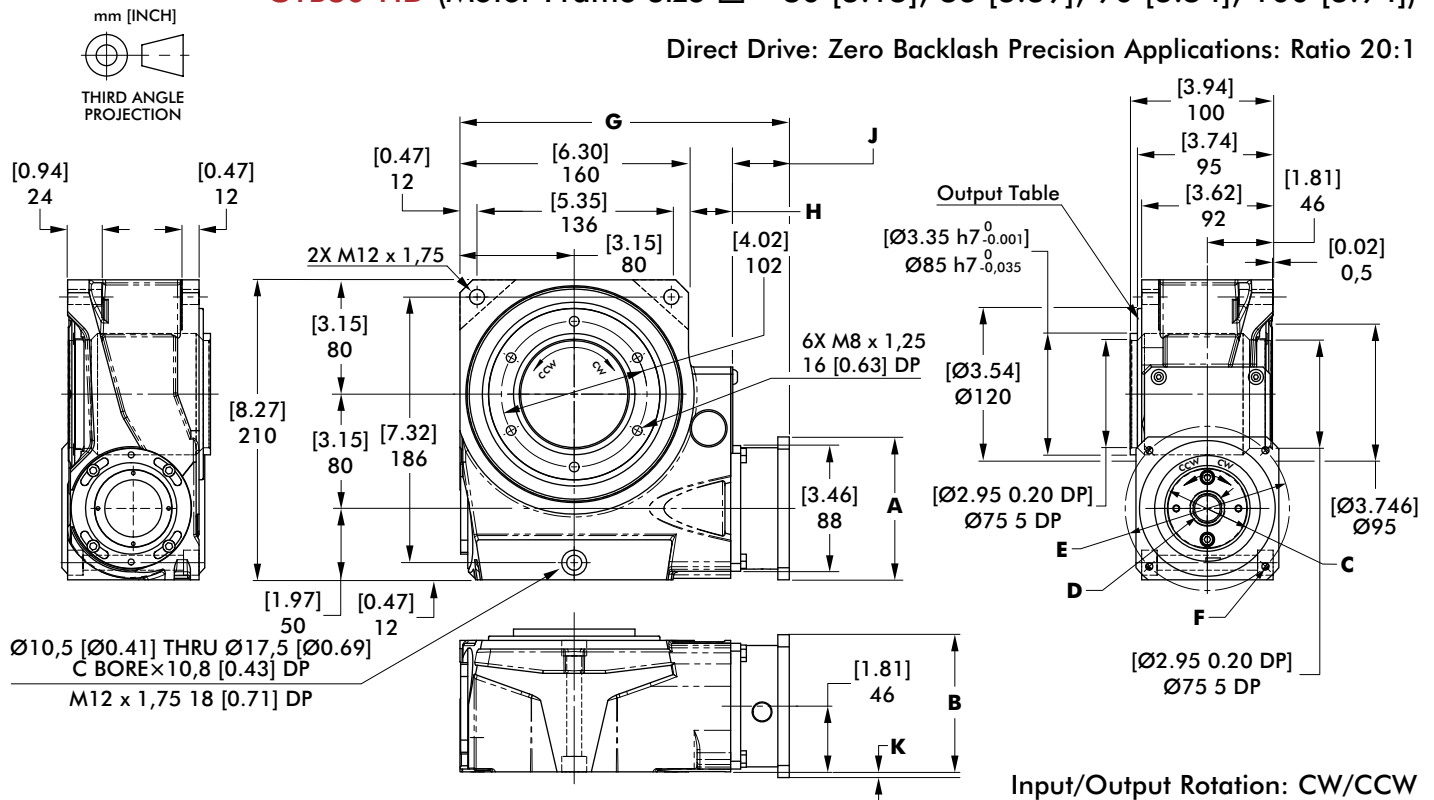

MI CODE	A Width mm [in]	B Height mm [in]	C Pilot Ø x Depth mm [in]	D Shaft Ø mm [in]	E Fixing Holes PCD mm [in]	F Fixing Holes Qty x Size mm [in]
HDA20	80 [3.15]	80 [3.15]	Ø70 [2.76] x 4,5 [0.18]	Ø19 [0.75]	Ø90 [3.54]	
HDB20	90 [3.54]	90 [3.54]	Ø80 [3.15] x 5,5 [0.22]	Ø14 [0.55]	Ø100 [3.94]	4X M6 THRU
HDC20				Ø16 [0.63]		
HDD20	100 [3.94]	100 [3.94]	Ø95 [3.74] x 3,5 [0.14]	Ø24 [0.94]	Ø115 [4.53]	
HDE20	80 [3.15]	80 [3.15]	Ø70 [2.76] x 4,5 [0.18]	Ø19 [0.75]	Ø90 [3.54]	4X M5 THRU
HDF20	100 [3.94]	100 [3.94]	Ø95 [3.74] x 3,5 [0.14]		Ø115 [4.53]	4X M8 THRU
HDG20				Ø95 [3.74] x 7,5 [0.30]		
HDH20	80 [3.15]	80 [3.15]	Ø70 [2.76] x 4,5 [0.18]	Ø16 [0.63]	Ø90 [3.54]	4X M6 THRU
HDJ20	90 [3.54]	90 [3.54]	Ø80 [3.15] x 5,5 [0.22]		Ø100 [3.94]	
HDK20	100 [3.94]	100 [3.94]	Ø95 [3.74] x 3,5 [0.14]	Ø22 [0.87]	Ø115 [4.53]	4X M8 THRU
HDL20	90 [3.54]	90 [3.54]	Ø80 [3.15] x 5,5 [0.22]	Ø10 [0.39]	Ø100 [3.94]	4X M6 THRU
HDM20	100 [3.94]	100 [3.94]	Ø95 [3.74] x 7,5 [0.30]	Ø22 [0.87]	Ø115 [4.53]	4X M8 THRU
HDN20	96 [3.78]	96 [3.78]	Ø80 [3.15] x 4 [0.16]	Ø19 [0.75]	Ø100 [3.94]	4X M6 THRU
HDP20	90 [3.54]	90 [3.54]	Ø80 [3.15] x 3,5 [0.14]	Ø16 [0.63]		4X M3 THRU
HDQ20	100 [3.94]	100 [3.94]	Ø95 [3.74] x 3,5 [0.14]	Ø19 [0.75]	Ø115 [4.53]	4X M8 THRU
HDR20	90 [3.54]	90 [3.54]	Ø80 [3.15] x 3,5 [0.14]	Ø14 [0.55]	Ø100 [3.94]	4X M6 THRU
HDS20						
HDT20	114 [4.49]	114 [4.49]	Ø110 [4.33] x 4 [0.16]	Ø24 [0.94]	Ø130 [5.12]	4X M8 THRU



Frame Size	G	H	J	K
80	226,5 [8.92]	31 [1.22]	35,5 [1.40]	--
86				
90	230,5 [9.07]		39,5 [1.56]	
100				4 [0.16]

GTB80 SERIES

Globoidal (Roller Gear) Servo Positioner | Dimensions

GTB80 Option Specifications

Dowel Hole Option -B, Housing -T: Output Table

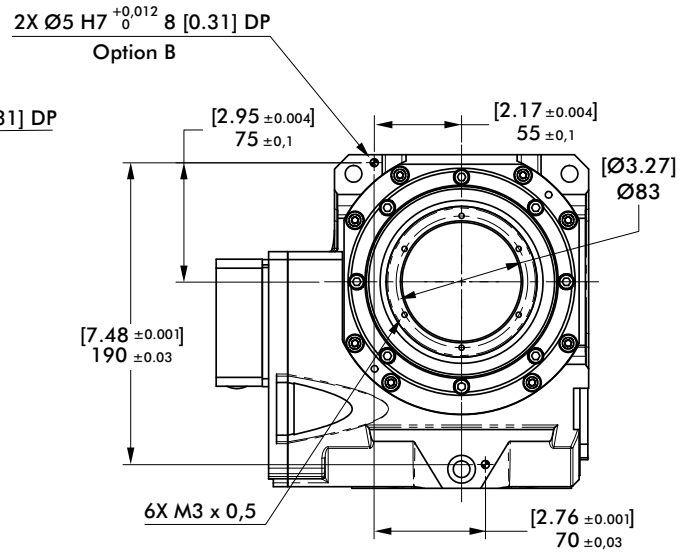
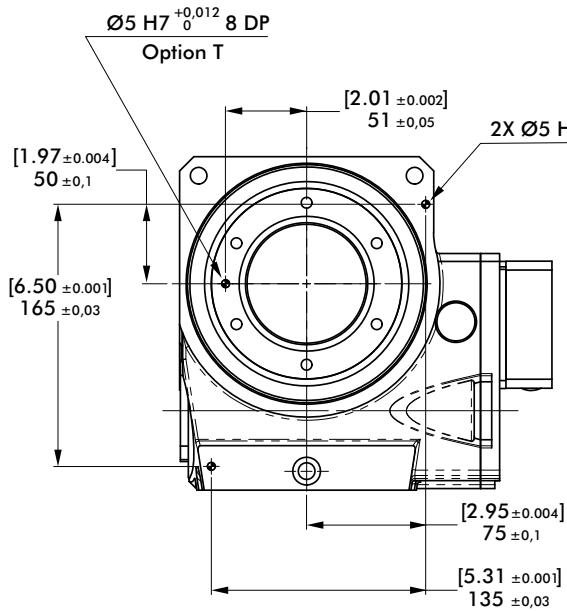

GTB100 SERIES

Globoidal (Roller Gear) Servo Positioner | Dimensions

GTB100-JG (Motor Frame Size □ = 90 [3.54], 100 [3.94], 130 [5.12])

Gear Drive: High Inertia applications: Ratio 60:1

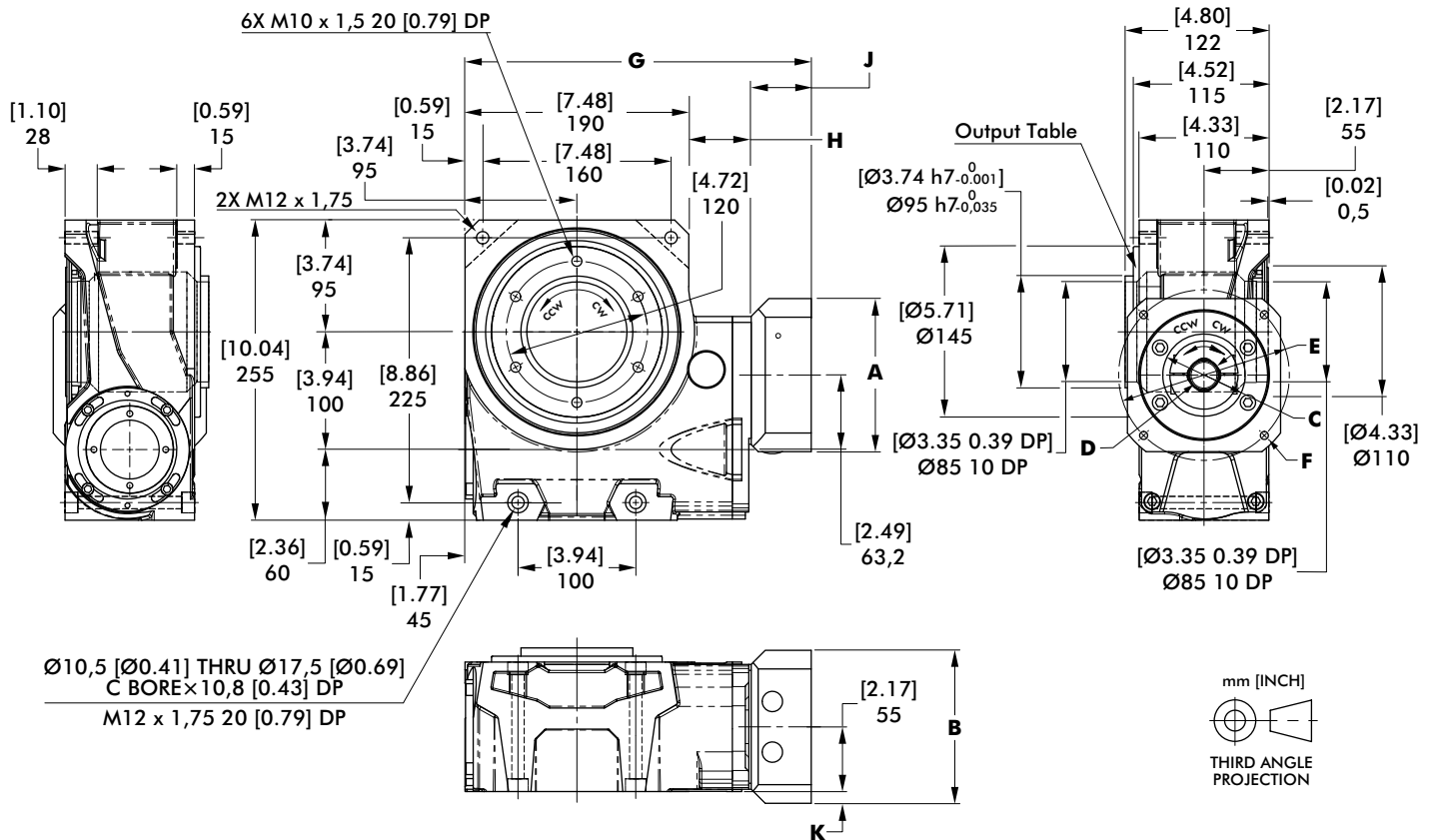

Input/Output Rotation: CW/CCW

MI CODE	A Width mm [in]	B Height mm [in]	C Pilot Ø x Depth mm [in]	D Shaft Ø mm [in]	E Fixing Holes PCD mm [in]	F Fixing Holes Qty x Size mm [in]
JGA20				Ø24 [0.94]		
JGA21	130 [5.12]	130 [5.12]	Ø110 [4.33] x 7 [0.28]	Ø19 [0.75]	Ø145 [5.71]	4X M8 x 22,5 [0.89] Deep
JGA22				Ø22 [0.87]		
JGB23				Ø14 [0.55]		
JGB24	90 [3.54]	90 [3.54]	Ø80 [3.15] x 9,5 [0.37]	Ø16 [0.63]	Ø100 [3.94]	
JGB25				Ø10 [0.39]		4X M6 x 17 [0.67] Deep
JGC20	100 [3.94]	100 [3.94]	Ø95 [3.74] x 5,5 [0.22]	Ø24 [0.94]	Ø115 [4.53]	
JGD26	90 [3.54]	90 [3.54]	Ø80 [3.15] x 9,5 [0.37]	Ø16 [0.63]	Ø100 [3.94]	
JGE22				Ø22 [0.87]		
JGE27	100 [3.94]	100 [3.94]	Ø95 [3.74] x 7,5 [0.30]	Ø19 [0.75]	Ø115 [4.53]	4X M8 x 22,5 [0.89] Deep
JGF27	96 [3.78]	96 [3.78]	Ø80 [3.15] x 5 [0.20]	Ø19 [0.75]	Ø100 [3.94]	4X M6 x 17 [0.67] Deep
JGG20	114 [4.49]	114 [4.49]	Ø110 [4.33] x 3,5 [0.14]	Ø24 [0.94]	Ø130 [5.12]	4X M8 x 22,5 [0.89] Deep



Frame Size	G	H	J	K
90	280 [11.02]	51 [2.01]	39 [1.54]	--
100	281 [11.06]	53 [2.09]	38 [1.50]	
130	280 [11.02]		51 [2.01]	10 [0.39]

GTB100 SERIES

Globoidal (Roller Gear) Servo Positioner | Dimensions

GTB100-JD (Motor Frame Size □ = 100 [3.94], 130 [5.12])

Direct Drive: Zero Backlash Precision Applications: Ratio 20:1

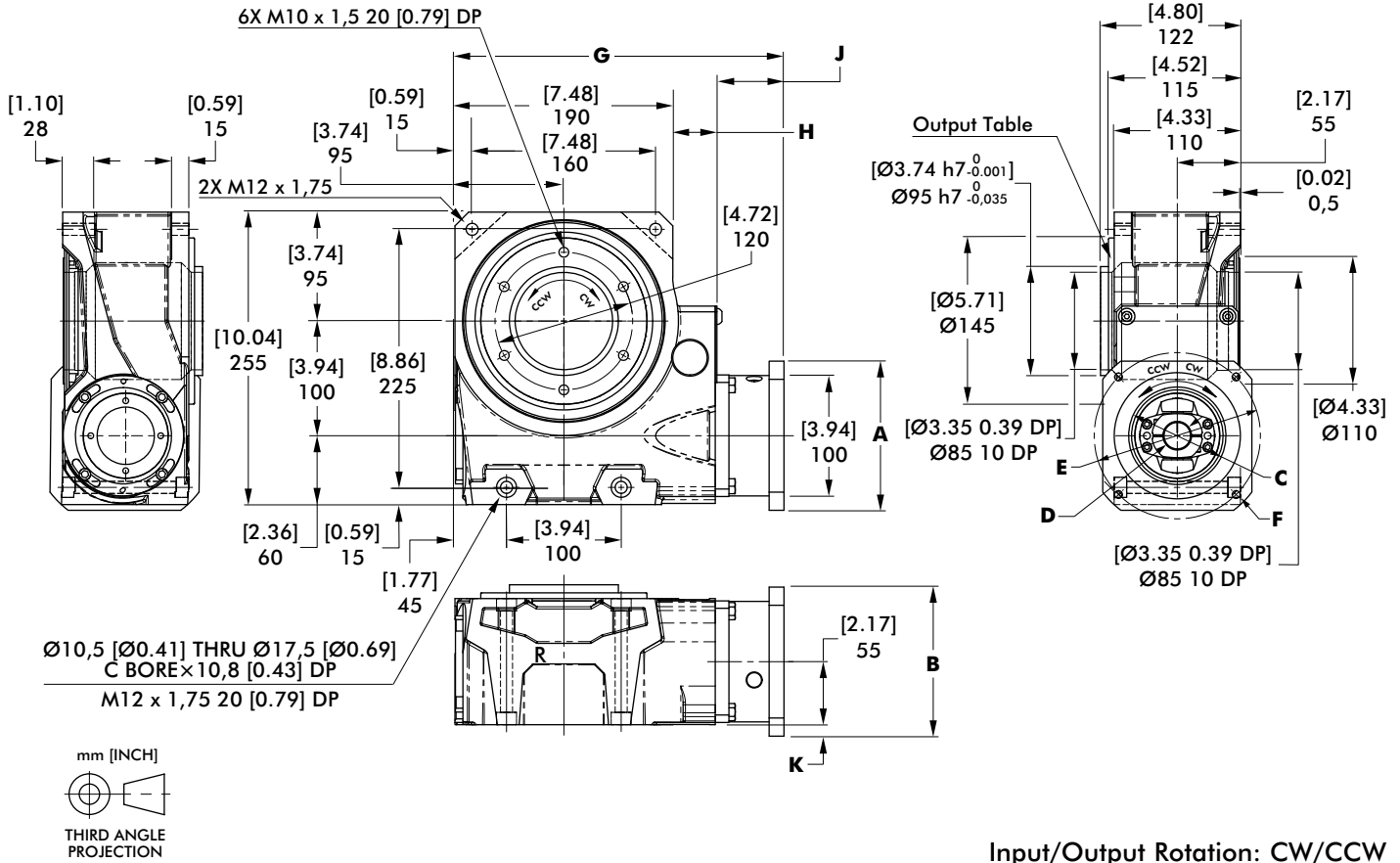

Input/Output Rotation: CW/CCW

MI CODE	A Width mm [in]	B Height mm [in]	C Pilot Ø x Depth mm [in]	D Shaft Ø mm [in]	E Fixing Holes PCD mm [in]	F Fixing Holes Qty x Size mm [in]
JDA20	130 [5.12]	130 [5.12]	Ø110 [4.33] x 6,5 [0.26]	Ø19 [0.75]	Ø145 [5.71]	4X M8 THRU
JDB20	130 [5.12]	130 [5.12]	Ø110 [4.33] x 6,5 [0.26]	Ø22 [0.87]	Ø145 [5.71]	4X M8 THRU
JDC20	100 [3.94]	100 [3.94]	Ø95 [3.74] x 5,5 [0.22]	Ø24 [0.94]	Ø145 [5.71]	4X M6 THRU
JDD20	100 [3.94]	100 [3.94]	Ø95 [3.74] x 5,5 [0.22]	Ø22 [0.87]	Ø115 [4.53]	4X M6 THRU
JDE20	100 [3.94]	100 [3.94]	Ø95 [3.74] x 7,5 [0.22]	Ø22 [0.87]	Ø115 [4.53]	4X M6 THRU
JDF20	126 [4.96]	126 [4.96]	Ø110 [4.33] x 4,5 [0.18]	Ø24 [0.94]	Ø130 [5.12]	4X M8 THRU
JDG20	100 [3.94]	100 [3.94]	Ø95 [3.74] x 3,5 [0.14]	Ø19 [0.75]	Ø115 [4.53]	4X M8 THRU
JDH20	114 [4.49]	114 [4.49]	Ø110 [4.33] x 3,5 [0.14]	Ø24 [0.94]	Ø130 [5.12]	4X M8 THRU
JDJ20	100 [3.94]	100 [3.94]	Ø95 [3.74] x 3,5 [0.14]	Ø19 [0.75]	Ø115 [4.53]	4X M8 THRU
JDK20	114 [4.49]	114 [4.49]	Ø110 [4.33] x 3,5 [0.14]	Ø24 [0.94]	Ø115 [4.53]	4X M8 THRU
JDL20	126 [4.96]	126 [4.96]	Ø110 [4.33] x 4,5 [0.18]	Ø19 [0.75]	Ø130 [5.12]	4X M8 THRU



90



130

Frame Size	G	H	J	K
100	284 [11.18]	38,5 [1.52]	55,5 [2.19]	--
130	287 [11.30]	38,5 [1.52]	58,5 [2.30]	10 [0.39]

GTB100 SERIES

Globoidal (Roller Gear) Servo Positioner | Dimensions

GTB100 Option Specifications

Dowel Hole Option -B, Housing -T: Output Table

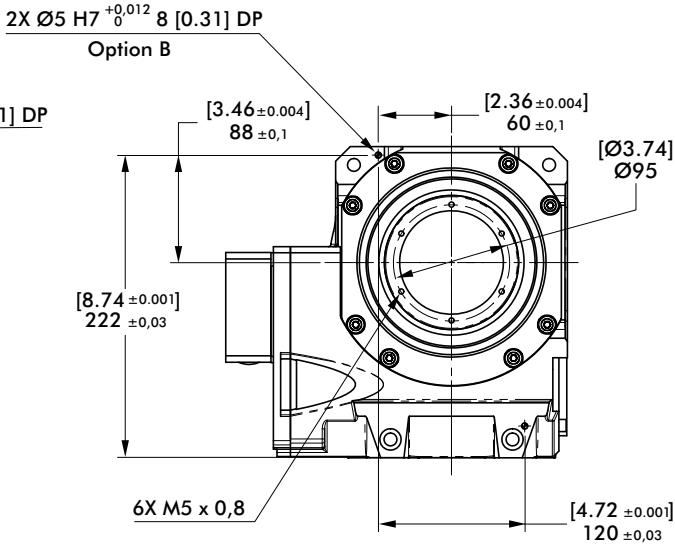
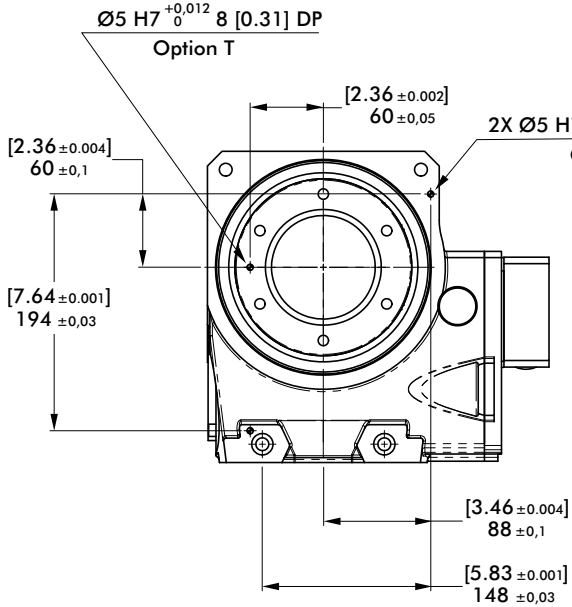

PGM SERIES

Parallel Gear Servo Positioner | Table of Contents



PGM40

Features:

Destaco's **CAMCO PGM Parallel Gear Reducers** is a precision servo reducer with parallel cam mechanism.

Light, accurate, and high cost performance offers easy to use character for wide range of applications. It features a pre-loaded precision parallel cam, low input inertia, through-hole design, integrated sealed tapered bearings, high performance grease and several motor options with integrated motor clamp system for easy fitting.

Table of Contents

IN-SRV-#

Features & Benefits	20
How to Order	21
Specifications	22
PGM40	23

Precision Servo Reducer with Pre-loaded Parallel Cam Structure

The PGM parallel cam mechanism with pre-loaded structure offers accurate and rigid indexing performance. It is designed for low input inertia and offers greater servo performance through a wide variety of motor options.

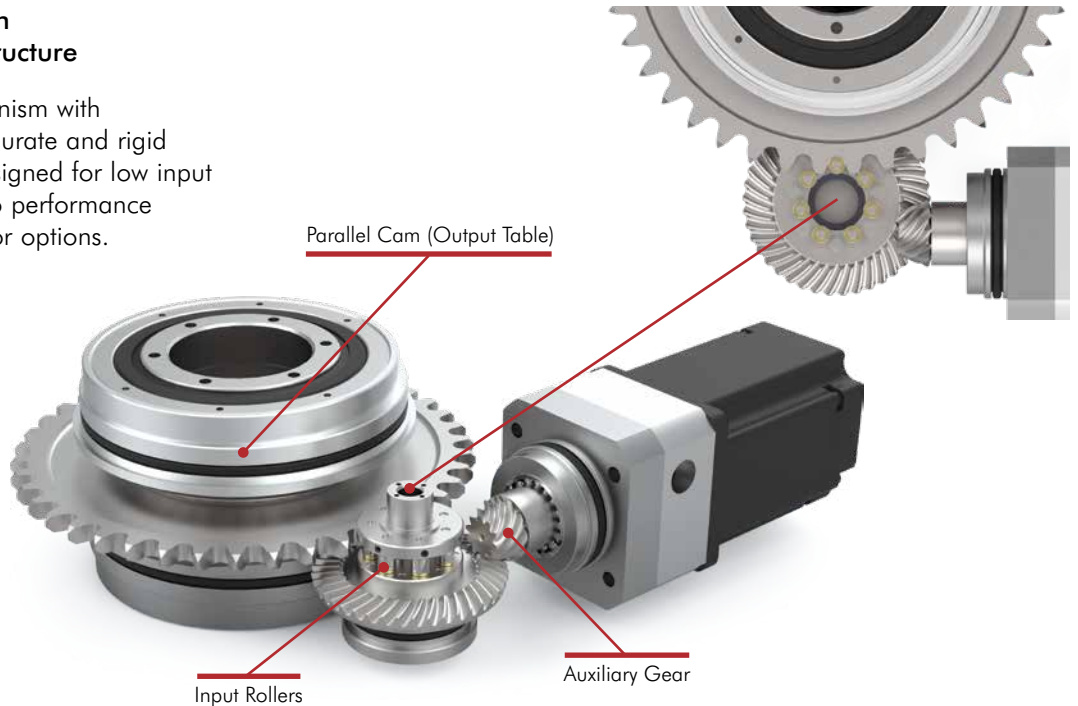

Thru-hole Design

Large central opening through the center of the output shaft structure is suitable for wiring and piping.



Integrated Motor Clamp System

The PGM offers a wide-variety of motor options that easily attach through the use of an integrated motor clamp.

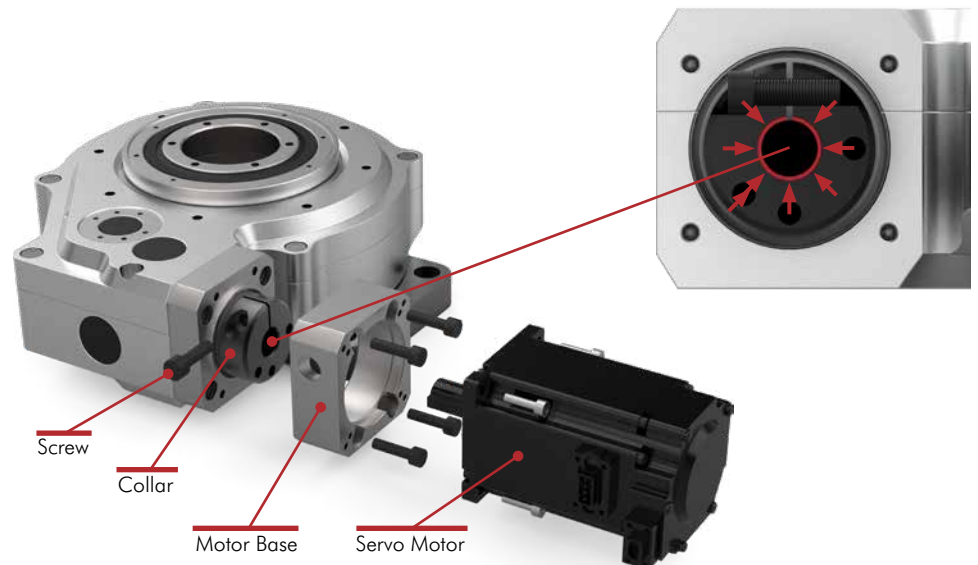

PGM SERIES

Parallel Gear Servo Positioner | How To Order

Parallel Gear Reducer Base Unit

PGM Series units can be interfaced with wide variety of servo motor manufacturers. Use the MI code tables to identify the supported motors for the PGM unit. Motors are ordered separately using the tables below.



PGM40 with Auxiliary Mounting Bracket. Motor not shown.

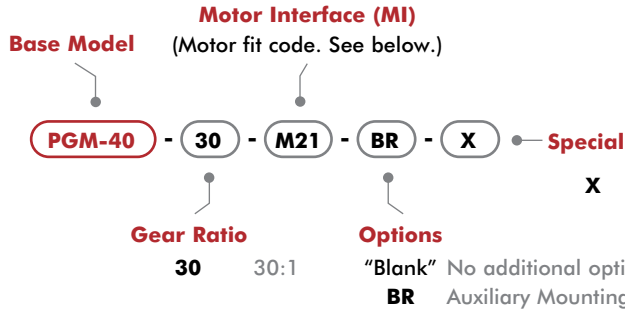

Make / Series	Model	mm [in]	kW [HP]	MI
Panasonic	A5 MSMD04	50 [1.97]	0,4 [0.54]	M21
	A5 MSME04	50 [1.97]	0,4 [0.54]	M21
	A5 MHMD04	50 [1.97]	0,4 [0.54]	M21
	A6 MSMF04	50 [1.97]	0,4 [0.54]	M21
	A6 MHMF04	50 [1.97]	0,4 [0.54]	M21

Make / Series	Model	mm [in]	kW [HP]	MI
ABB	ESM06X-201-302	50 [1.97]	0,2 [0.27]	M22
	ESM06X-401-302	50 [1.97]	0,4 [0.54]	M22
FANUC	β βiS1/6000	50 [1.97]	0,5 [0.67]	M22
	SV SV-M020	50 [1.97]	0,2 [0.27]	M22
Keyence	SV SV-M040	50 [1.97]	0,4 [0.54]	M22
	SV2 SV2-M020	50 [1.97]	0,2 [0.27]	M22
	SV2 SV2-M040	50 [1.97]	0,4 [0.54]	M22
Mitsubishi	J3 HF-KP23	50 [1.97]	0,2 [0.27]	M22
	J3 HF-KP43	50 [1.97]	0,4 [0.54]	M22
	J3 HF-MP23	50 [1.97]	0,2 [0.27]	M22
	J3 HF-MP43	50 [1.97]	0,4 [0.54]	M22
	J4 HG-KR23	50 [1.97]	0,2 [0.27]	M22
	J4 HG-KR43	50 [1.97]	0,4 [0.54]	M22
	J4 HG-MR23	50 [1.97]	0,2 [0.27]	M22
Sanyo	R2 R2AA06020F	50 [1.97]	0,2 [0.27]	M22
	R2 R2AA06040F	50 [1.97]	0,4 [0.54]	M22
	R2 R2AA06040H	50 [1.97]	0,4 [0.54]	M22
Yaskawa	Σ5 SGMAV-02A	50 [1.97]	0,2 [0.27]	M22
	Σ5 SGMAV-04A	50 [1.97]	0,4 [0.54]	M22
	Σ5 SGMAV-06A	50 [1.97]	0,55 [0.74]	M22
	Σ5 SGMJV-02A	50 [1.97]	0,2 [0.27]	M22
	Σ5 SGMJV-04A	50 [1.97]	0,4 [0.54]	M22
	Σ5 SGMJV-06A	50 [1.97]	0,6 [0.80]	M22
	Σ7 SGM7J-02A	50 [1.97]	0,2 [0.27]	M22
	Σ7 SGM7J-04A	50 [1.97]	0,4 [0.54]	M22
	Σ7 SGM7J-06A	50 [1.97]	0,6 [0.80]	M22
	Σ7 SGM7A-02A	50 [1.97]	0,2 [0.27]	M22
Σ7 SGM7A-04A	50 [1.97]	0,4 [0.54]	M22	
Σ7 SGM7A-06A	50 [1.97]	0,6 [0.80]	M22	

Easily Integrates with a Variety of Servo Motor Manufacturers

ABB
FANUC
Mitsubishi
Sanyo

Allen Bradley
Keyence
Panasonic
Yaskawa

□ = Motor Frame Size

Make / Series	Model	mm [in]	kW [HP]	MI
Allen Bradley	VPL VPL-A0632F	55 [2.17]	0,39 [0.52]	M23
	VPL VPL-B0632F	55 [2.17]	0,37 [0.50]	M23
	VPL VPL-B0632T	55 [2.17]	0,54 [0.72]	M23

Make / Series	Model	mm [in]	kW [HP]	MI
Allen Bradley	VPL VPL-A0752C	70 [2.76]	0,49 [0.66]	M24
	VPL VPL-A0752E	70 [2.76]	0,66 [0.89]	M24
	VPL VPL-B0752E	70 [2.76]	0,67 [0.90]	M24
	VPL VPL-B0752F	70 [2.76]	0,8 [1.07]	M24
	VPL VPL-B0752M	70 [2.76]	0,81 [1.09]	M24

Motor Interface (MI) [in] mm						
MI	a	b	c	d	e	f
M21	[0,91-1,22]	[≤0,16]	[1,97]	[≤0,20]	[2,76]	M4
M22	23-31	≤4	50	≤5	70	
M23	[0,79]	[0,07]	[1,57]	[0,08]	[2,48]	M5
	20		40		63	
M24	[0,91]	1,7	[2,36]	2,1	[2,95]	
	23		60		75	

Note: Follow the instruction manual for motor fitting and installing. Improper handling can cause damages and malfunction.

General Specifications	Symbol	Units	PGM40
Axis distance		mm [in]	101 [3.98]
Output hollow dia.		mm [in]	50 [1.97]
Gear ratio	i		30
Max start / stop torque	T _U	N-m [in-lb]	63,9 [566]
Allowable mean output speed	N _m	rpm	100
Allowable ultimate output speed	N _U	rpm	150
Inertia moment on input axis	J	[lb-ft ²] x 10 ⁻⁴ kg.m ² x 10 ⁻⁴	[10.63] 0,448
Backlash		sec	60
Allowable axial Load on output	P _a	N [lbs]	1415 [318]
Allowable radial Load on output	P _r	N [lbs]	2172 [488]
Allowable moment Load on output	P _{mean}	N-m [in-lb]	102 [903]
Lubrication (Maintenance Free)			Grease
Weight		kg [lbs]	6,7 [14.77]

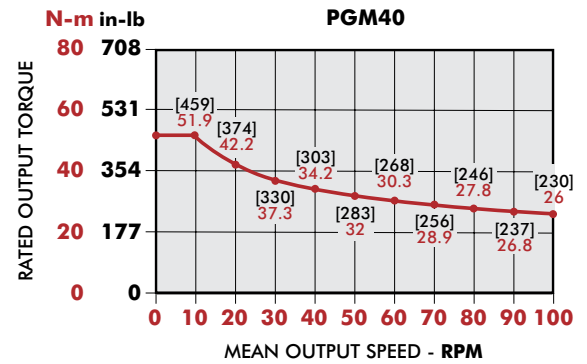

Sizing PGM Series for an Application

(Contact Destaco for sizing application support)

1. Load diagram

Check motion profile and resultant inertia torque.
(Add working torque if applied).

Start and stop speed can be simplified to average speed within a segment.

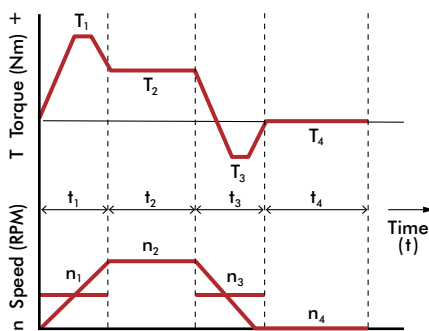

2. Check key conditions

$$\text{Mean torque } T_{mean} = \sqrt{\frac{\frac{10}{3} \left(n_1 \cdot t_1 \cdot |T_1| \frac{10}{3} + n_2 \cdot t_2 \cdot |T_2| \frac{10}{3} + \dots + n_n \cdot t_n \cdot |T_n| \frac{10}{3} \right)}{n_1 \cdot t_1 + n_2 \cdot t_2 + \dots + n_n \cdot t_n}} \quad (\text{N-m})$$

$$\text{Mean output speed } n_{mean} = \frac{n_1 \cdot t_1 + n_2 \cdot t_2 + \dots + n_n \cdot t_n}{t_1 + t_2 + \dots + t_n} \quad (\text{rpm})$$

$$\text{Max output speed } n_{max} \quad (\text{rpm})$$

3. Pre-selection

Choose a size that meets these criteria.

$$T_{mean} < \text{Maximum rated output torque (N-m)}$$

$$n_{mean} < \text{Allowable mean output speed } N_m \text{ (rpm)}$$

$$n_{max} < \text{Allowable ultimate output speed } N_u \text{ (rpm)}$$

4. Check specifications

Start/stop torque T₁ < Maximum rated output torque (N-m)
T₃ < Maximum rated output torque (N-m)

Operation condition factor Smooth without any impact or sudden load f = 1.0

Normal, but occasional emergency stop f = 1.5

Operation with frequent impact or sudden load f = 3.0

$$\text{Estimated lifetime } L_h = 12000 \left(\frac{T_{op}}{f \cdot T_{mean}} \right)^{\frac{10}{3}} \text{ (hours)}$$

5. Selection complete

If above values don't satisfy requirements, go back to step 2 and 3 to re-select size.

PGM40

Parallel Gear Servo Positioner | Dimensions

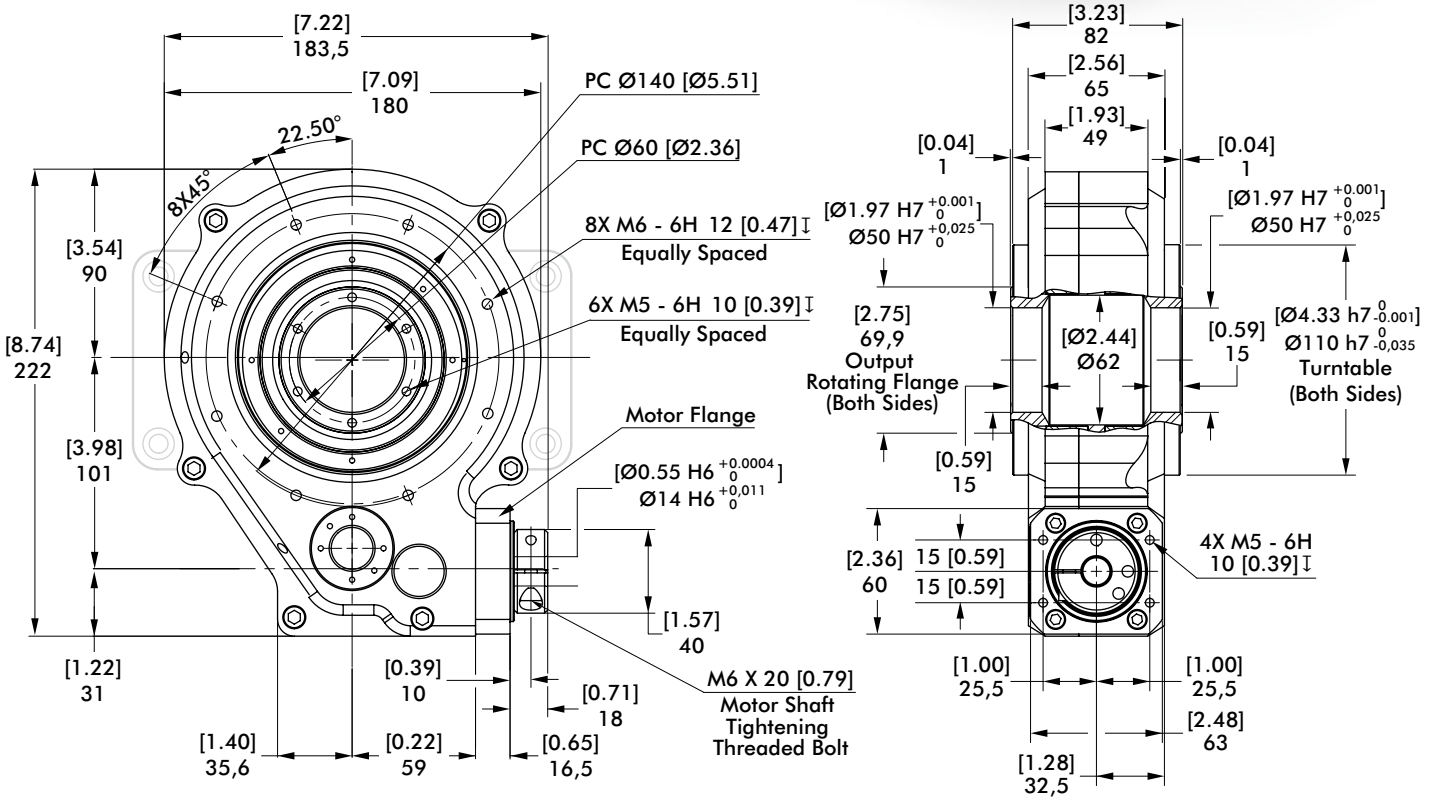
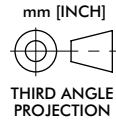

Optional Fixture Bracket

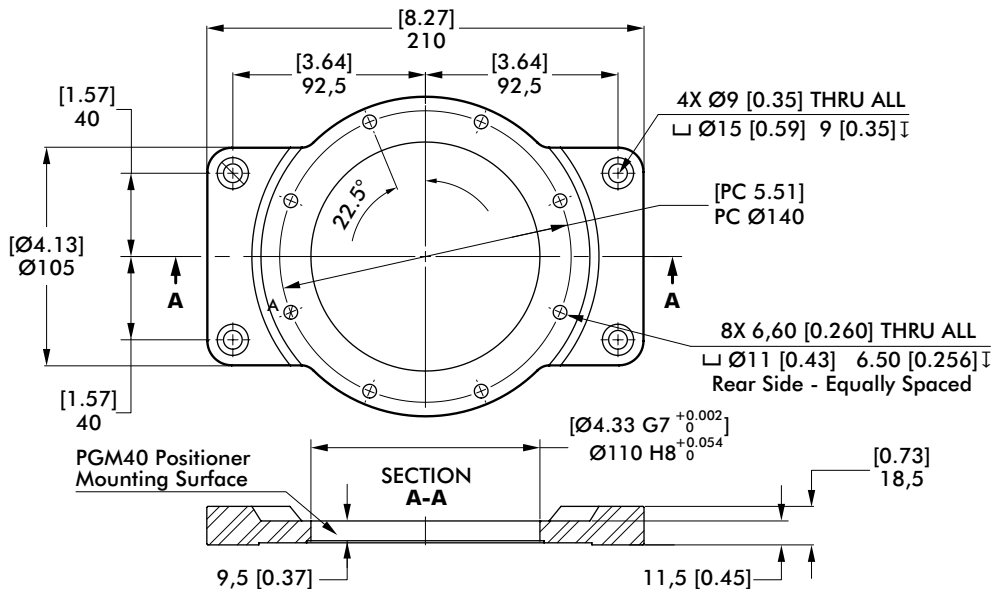

Parallel Gear Servo Positioner | Motor Base (by MI Code) Dimensions

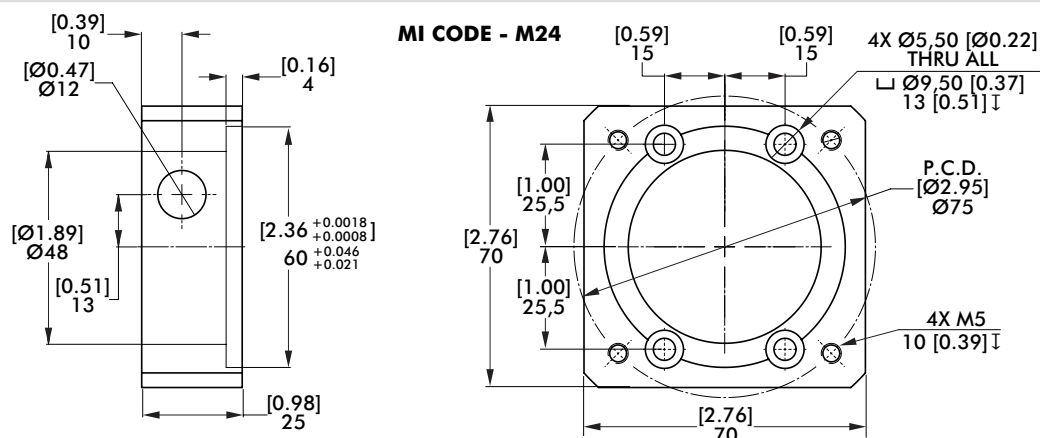
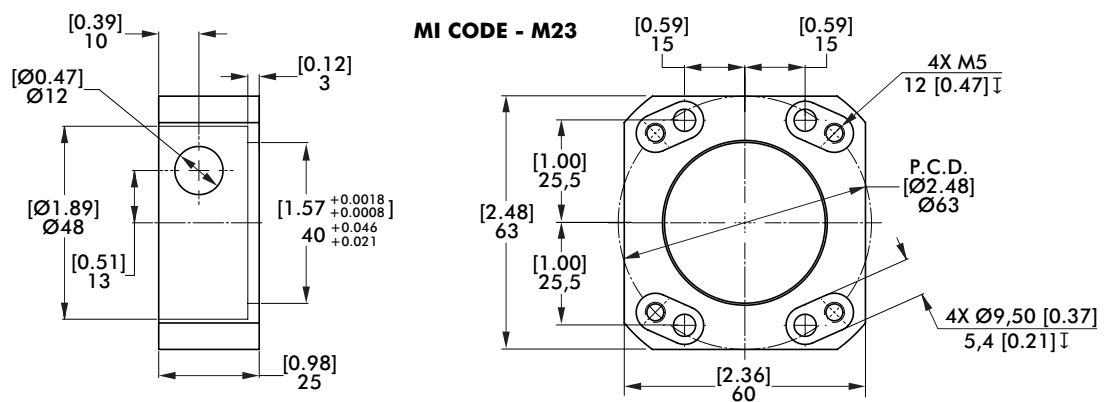
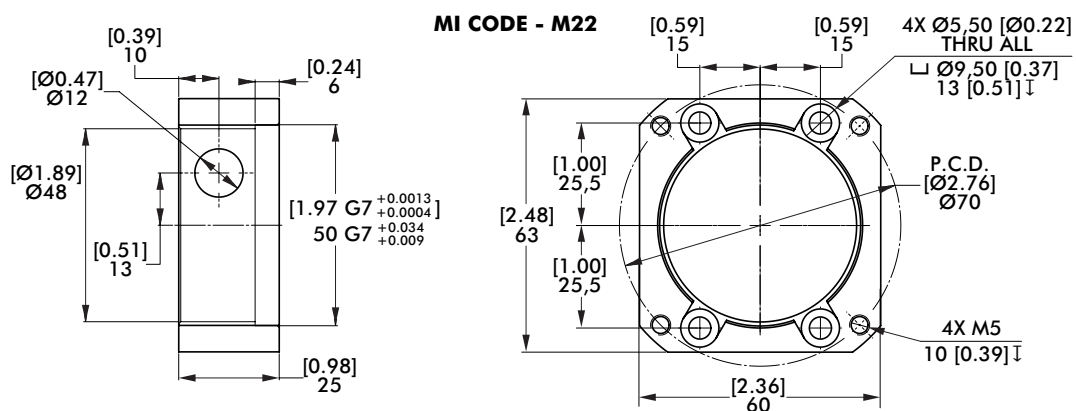
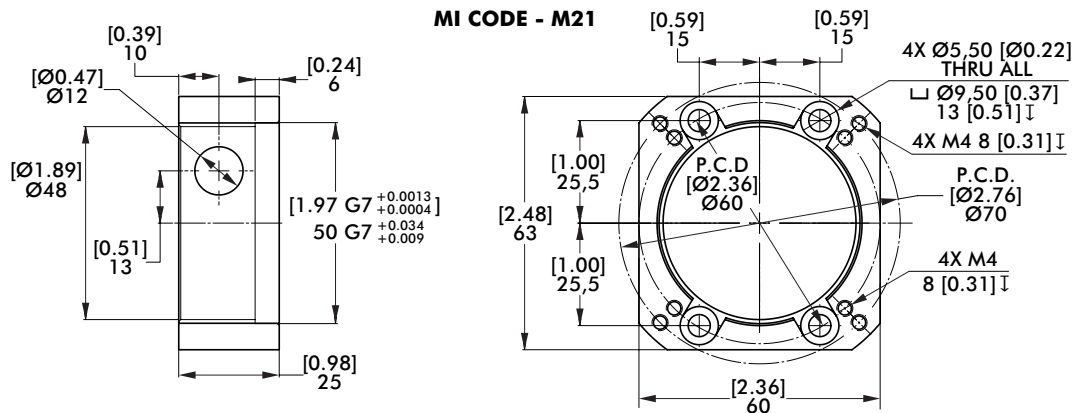

RSD SERIES

Rotary Servo Drive | Product Overview



Flange output



Shaft output



Internal shrink disk output



Shrink disk output

Smarter Indexing

The **CAMCO RSD Rotary Servo Drive** is a zero-backlash, cam-actuated drive compatible with industry-standard servo motors for precise control, efficiency and flexibility.

Universal mounting

Maintenance-free operation

Large output bearing for greater overturning moment capacity

Large thru-hole for accessory lines (electric, pneumatic, etc.)

IP-65 rating

Class 100 rated with Med-Redi preparation

Features

Designed to accept a variety of servo motors

Preloaded system

- Zero backlash
- High accuracy
- Smooth motion
- Quiet operation
- High speed

Indexing flexibility

- Run different parts on the same indexer
- Variable indexing: reversing, sorting, vary distance with each index

4:1 to 18:1 ratios in a single stage

Flange Output

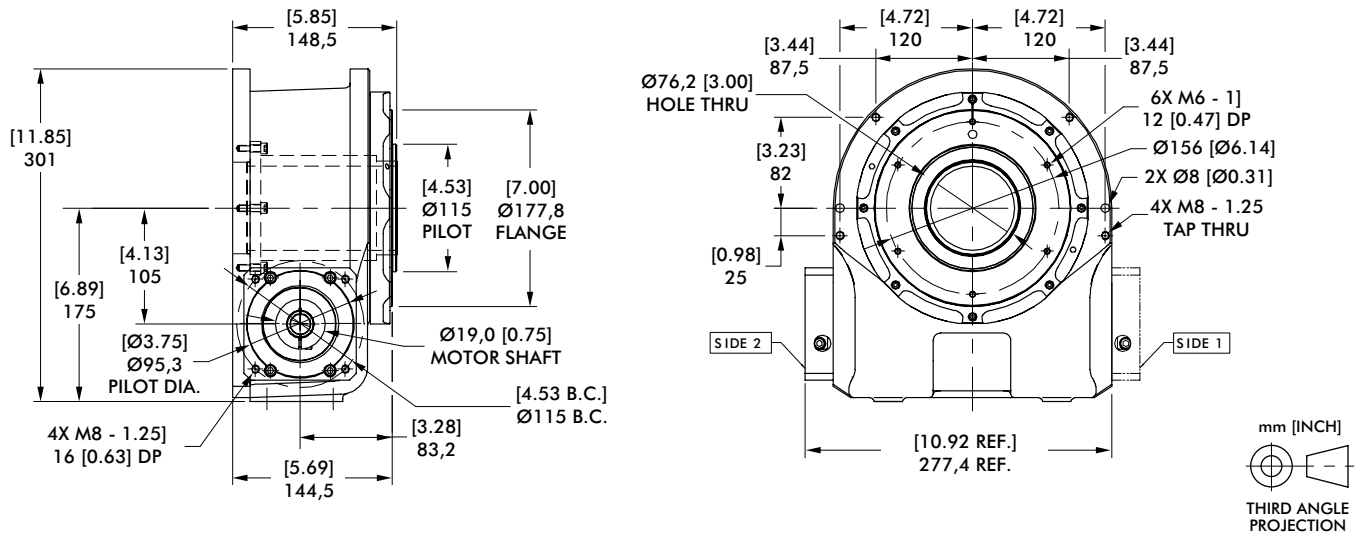

Shaft Output

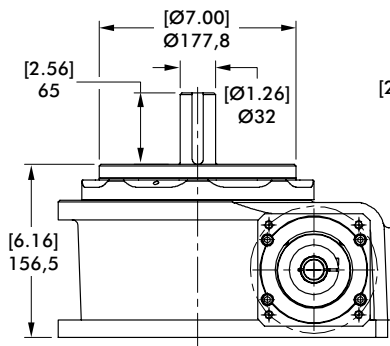

Internal Shrink Disk Output

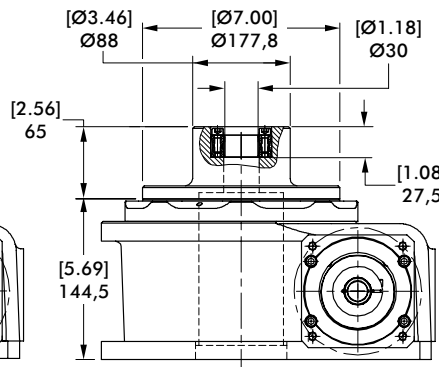

Shrink Disk Output

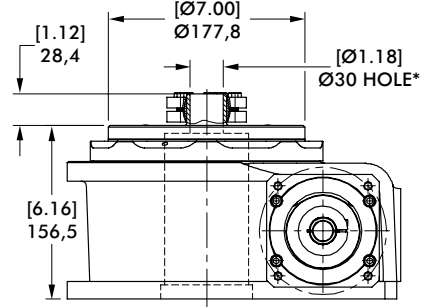

* Also available with 40 mm [1.57 in] bore.

Specifications	Units	Standard Ratios					Other Available Ratios				
Single Reduction Ratio	-	8:1	16:1	4:1	5:1	6:1	9:1	12:1	15:1	18:1	
Maximum Torque Capacity	[in-lb] N-m	[3540] 400	[3755] 424	[2950] 333	[3195] 361	[3355] 379	[3595] 406	[3695] 418	[3740] 423	[3770] 426	
Maximum Inertia on Output Dial	[lb-ft ²] kg-m ²	[1622] 68	[6488] 273	[406] 17	[634] 27	[912] 38	[2053] 87	[3649] 154	[5702] 240	[8211] 346	
Unit Output Inertia Reflected at Input Shaft	[lb-ft ²] kg-m ²	[0.44] 0,05	[0.33] 0,04	[0.94] 0,11	[0.73] 0,08	[0.55] 0,06	[0.40] 0,05	[0.43] 0,05	[0.34] 0,04	[0.31] 0,03	
Stiffness	in-lb/arcmin N-m/arcmin	[169] 19,1	[179] 20,2	[141] 15,9	[153] 17,3	[160] 18,1	[172] 19,4	[177] 20	[179] 20,2	[180] 20,3	
Input Torque of Unit Only	N-m [in-lb]	2,26 [20]									
Maximum Axial Load	kN [lbf]	10 [2270]									
Maximum Radial Load	kN [lbf]	4 [910]									
Maximum Offset Load (Overturning Moment)	N-m [in-lb]	359 [3180]									
Output Face Flatness	TIR mm [in]	0,05 [0.002]									
Axial Run-Out	mm [in]	0,04 [0.0015]									
Accuracy	arc seconds	±30									
Repeatability	arc seconds	±7									
Torsional Backlash	arc seconds	0									
Operating Temperature Range	C° [F°]	60 [140] Minimum									

PRECISION INDEXING SOLUTIONS

Features and Benefits

The **CAMCO RDM Series** is a line of cam-operated rotary index drives, designed to move a wide array of products and components smoothly and with precision. Preloaded for no backlash, they have the capacity for handling high loads and speeds with controlled acceleration and deceleration for repeatable, accurate positioning.

- High precision, hardened cams available in standard and special motions
- Superior accuracy at the working radius when compared to a traditional indexer
- Sealed 4-point contact output bearing and large cam followers for superior accuracy and load capacity
- 60 Station capacity, ideal for multi-part automatic assembly machines
- Center through hole accommodates machine utilities
- Servo-driven solutions available for complex or variable indexing profiles
- Optional Output Overload Clutch available



Application Examples

Cycle on Demand Indexer with Fixed Number of Stations

- RDM indexer with user controlled variable dwell time
- Single index cycle with user controlled variable dwell time
- Index time is controlled by varying frequency setting of inverter drive
- 60 or 30 indexing cycles per minute using an AC or DC motor and drive respectively
- Increased productivity cycle rates with an Output Clutch-Brake option

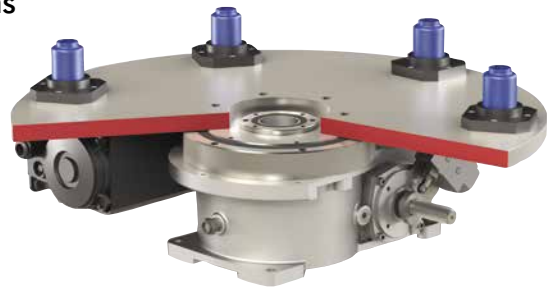

Cambot Flexible Pick and Place Solutions

- Servo driven indexer supporting high moment capacity payloads
- Large output flange for mounting a custom end-effector solution
- Integrate Destaco's versatile grippers, slides and vacuum products for pick and place actuation



CAMCO XPRESS PROGRAM

601RDM and 902RDM Series

Destaco continues to offer excellent service to our customers by providing the most common models of our **Camco RDM Series** as fast as you need them.



Base Models

Please contact your Destaco Camco Sales Team to learn more features of the RDM Series and details of the Xpress Program.



601RDM
Load Capacity:
 Radial: 945 lbs
 Thrust/Axial: 2360 lbs



902RDM
Load Capacity:
 Radial: 3540 lbs
 Thrust/Axial: 7000 lbs
 with Standard Torque and
 Detector Plate Settings



Stops		Motion	Reducer	Ratio	Motor	Optional Controller	Clutch
(M)601RDM	(M)902RDM						
					601RDM W/0.33HP 230/460V or 90/180V DC Motor	Allen Bradley PowerFlex 523 / 525 <small>(Allen Bradley, PowerFlex are registered brands of Rockwell Automation)</small>	
					902RDM W/1HP, 56C 230/460V or 90/180V DC Motor		

RDM SERIES

Rotary Index Drive | How To Order

Base Model*		Option Tables Page #	Index Mounting (See Figure 1)	Reducer/Motor (Table 1)	Reducer Mounting (See Figure 2)	Cycling Sensor (See Figure 3)	Description
Imperial	Metric						
N/A	80RDM	5	1	Reducer/Motor (Table 1) Note: Set Reducer Mounting option to 0 when Reducer/Motor option is 0000.	0 = No Reducer	0 = No Sensors	
601RDM	M601RDM	11	2		A J	A	Single Cam w/PNP Prox
902RDM	M902RDM	17	3		B K	B	Single Cam w/NPN Prox
N/A	1100RDM	23	4		C L	C	Dual Cam w/PNP Prox
1305RDM	M1305RDM	29	5		D M	D	Dual Cam w/NPN Prox
1800RDM	M1800RDM	35	6		E N	E	Single Cam/Prox Bracket
				F P	F	Dual Cam/Prox Bracket	
				G R	G	Single Cam, w/Mech LS	
				H S	H	Dual Cam, w/Mech LS	

*Right Hand Cam only

601RDM - **C** - **T** - **P** - **RM2E** - **000** - **C** - **L** - **A** - **40EA** - **A02**

Motion	Description
A	2-Stop-330
B	3-Stop-330
C	4-Stop-270
D	4-Stop-330
E	6-Stop-270
F	6-Stop-330
G	8-Stop-270
H	8-Stop-330
I	12-Stop-270
J	12-Stop-330
K	16-Stop-270
L	16-Stop-330
M	8:1 Constant-Lead
N	12:1 Constant-Lead
P	16:1 Constant-Lead
R*	24:1 Constant-Lead

Center Post	Code	Description
All Sizes	0	No Reducer
	P	Center Post
902 1100 1305	T	Tool Plate Mounting Holes
	B	Center Post + Tool Plate Mounting Holes



Motor Brake Settings (Table 2)	Reducer Gear Ratio (Table 3)	Output Clutch (Table 4)	Motor Control (Table 5)
--------------------------------	------------------------------	-------------------------	-------------------------



Input Shaft Configuration/Rotation

Relative Rotation for Right Hand Cam:

Side 1: CW Input, CCW Output

Side 2: CCW input, CW Output

NOTE: Input can be driven in either direction. Reducer, Motor and adapter plates can be mounted on either side 1 or side 2 to drive input.

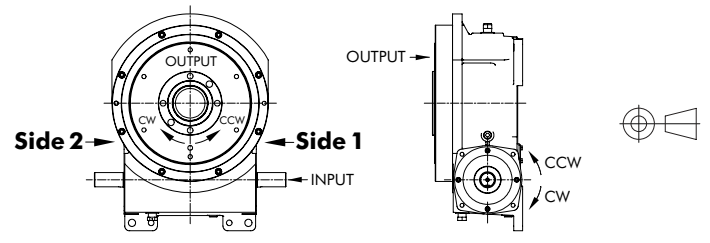

Index Mounting (Figure 1)

OVOI (output vertical, over input)	OVUI (output vertical, under input)	OHOI (output horizontal, over input)	OHUI (output horizontal, under input)	H-S1-UP (output horizontal, side 1 up)	H-S2-UP (output horizontal, side 2 up)
1	2	3	4	5	6

Other Motions (stops and index periods) available. Contact your DESTACO sales representative for more information.

Gear Reducer Mounting Positions (Figure 2)

		Mounting "A"		Mounting "B"	
		Right Hand	Left Hand	Right Hand	Left Hand
SIDE 1					
SIDE 2					

Cycling Sensor Options (Figure 3)

Single Cam with (A) PNP or (B) NPN Proximity Sensor	Dual Cam with (A) PNP or (B) NPN Proximity Sensor	Single Cam with Proximity Sensor Bracket	Dual Cam with Proximity Sensor Bracket	Single Cam with Mechanical Limit Switch	Dual Cam with Mechanical Limit Switch

80RDM SERIES

Rotary Index Drive | How To Order

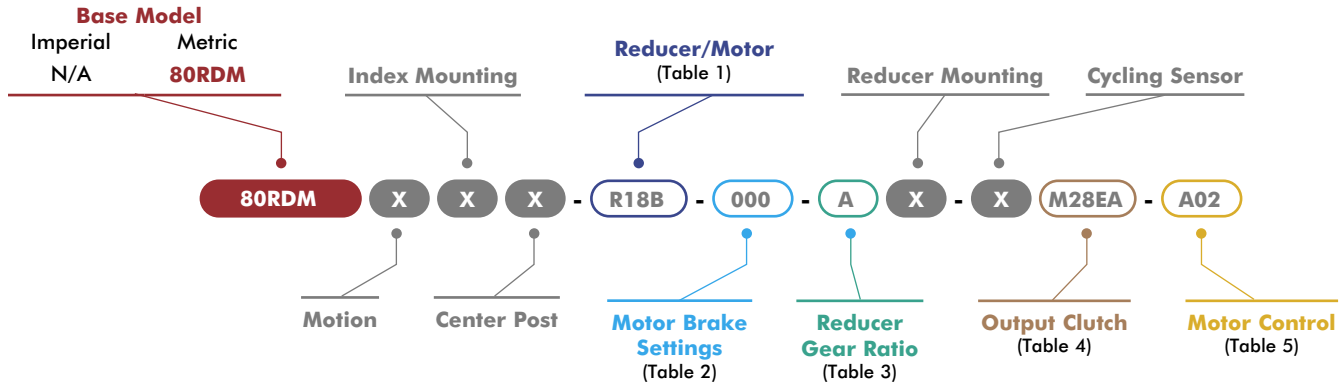

X = See Page 3 for option information.

1 Reducer/Motor Options

Code	Description
0000	No Reducer or Motor*
R180 Motors	
R18X	R180 Adapter only*
R18A	R180 Reducer
R18B	R180 Reducer with 0.33HP 230/460V AC Motor
R18C	R180 Reducer with 0.33HP 90V DC Motor
R18D	R180 Reducer with 0.33HP 180V DC Motor
STM RMI-28/40 Motors	
RM1A	RMI-28 Adapter only*
RM1B	STM RMI-28/LFB/IEC56-B14 Reducer
RM1C	STM RMI-28/LFB with 0.09kW Motor
RM2A	RMI-40 Adapter only*
RM2B	STM RMI-40/LFB/IEC63-B14 Reducer
RM2C	STM RMI-40/LFB/IEC71-B14 Reducer
RM2D	STM RMI-40/LFB with 0.18kW Motor
RM2E	STM RMI-40/LFB with 0.25kW Motor

*All Reducer/Motor adapters require Gear Ratio option to be 0.

2 Motor Brake

Code	Description
000	No Brake

3 Reducer Gear Ratios*

Code	Description	
	R180	STM RMI-28/40
0	N/A	N/A
A	10:1	10:1
B	15:1	15:1
C	20:1	20:1
D	25:1	28:1
E	30:1	40:1
F	40:1	49:1
G	50:1	56:1
H	60:1	70:1

*All Reducer/Motor adapters require Gear Ratio option to be 0.
Select Gear ratio column based on the reducer type selected.

4 Output Clutch & Settings

80RDM Metric Clutch Models	
Code	Description
0000	No Output Overload Clutch
M28DA	M2.8D W/54 Nm, Standard*
M28DB	M2.8D W/96 Nm, Standard*
M28DC	M2.8D W/147 Nm, Standard*
M28DD	M2.8D W/249 Nm, Standard*
M28DE	M2.8D W/350 Nm, Standard*
M28DF	M2.8D W/45 Nm, Standard*
M28DG	M2.8D W/79 Nm, Standard*
M28DH	M2.8D W/124 Nm, Standard*
M28DJ	M2.8D W/203 Nm, Standard*
M28DK	M2.8D W/54 Nm, Thru-Hole
M28DL	M2.8D W/96 Nm, Thru-Hole
M28DM	M2.8D W/147 Nm, Thru-Hole
M28DN	M2.8D W/249 Nm, Thru-Hole
M28DP	M2.8D W/350 Nm, Thru-Hole
M28DQ	M2.8D W/45 Nm, Thru-Hole
M28DR	M2.8D W/79 Nm, Thru-Hole
M28DS	M2.8D W/124 Nm, Thru-Hole
M28DT	M2.8D W/203 Nm, Thru-Hole
M28EA	M2.8D W/54 Nm, Standard, EZ*
M28EB	M2.8D W/96 Nm, Standard, EZ*
M28EC	M2.8D W/147 Nm, Standard, EZ*
M28ED	M2.8D W/249 Nm, Standard, EZ*
M28EE	M2.8D W/350 Nm, Standard, EZ*
M28EF	M2.8D W/45 Nm, Standard, EZ*
M28EG	M2.8D W/79 Nm, Standard, EZ*
M28EH	M2.8D W/124 Nm, Standard, EZ*
M28EJ	M2.8D W/203 Nm, Standard, EZ*
M28EK	M2.8D W/54 Nm, Thru-Hole, EZ
M28EL	M2.8D W/96 Nm, Thru-Hole, EZ
M28EM	M2.8D W/147 Nm, Thru-Hole, EZ
M28EN	M2.8D W/249 Nm, Thru-Hole, EZ
M28EP	M2.8D W/350 Nm, Thru-Hole, EZ
M28EQ	M2.8D W/45 Nm, Thru-Hole, EZ
M28ER	M2.8D W/79 Nm, Thru-Hole, EZ
M28ES	M2.8D W/124 Nm, Thru-Hole, EZ
M28ET	M2.8D W/203 Nm, Thru-Hole, EZ

*Cannot be used with center post option P

5 Motor Control

Code	Description	
000	NO MOTOR CONTROL	
A01		120V 1Ph
A02	(AC) PowerFlex 523 1HP	240V 1Ph
A03		480V 3Ph
A04		120V 1Ph
A05	(AC) PowerFlex 525 1HP	240V 1Ph
A06		480V 3Ph
D01		Uni-Directional
D02	(DC) Varipak 1HP 90VDC	Bi-Directional
D03		Uni-Directional
D04	(DC) Varipak 2HP 180VDC	Bi-Directional

Maximum Inertia x 1000 kg-cm ² [lb-in ²] for standard package							
Stops	Motion Time [seconds]						
	0.458	0.611	0.764	0.917	1.222	1.528	1.833
2	0 [0]	3 [1]	6 [2]	15 [5]	29 [10]	47 [16]	67 [23]
3	3 [1]	9 [3]	20 [7]	32 [11]	61 [21]	94 [32]	138 [47]
4	6 [2]	18 [6]	38 [13]	67 [23]	135[46]	217 [74]	304 [104]
6	15 [5]	38 [13]	82 [28]	126 [43]	246 [84]	401 [137]	559 [191]
8	20 [7]	44 [15]	73 [25]	114 [39]	222 [76]	372 [127]	559 [191]
12	50 [17]	99 [34]	167 [57]	258 [88]	497 [170]	559 [191]	559 [191]
16	47 [16]	91 [31]	152 [52]	231 [79]	448 [153]	559 [191]	559 [191]
Reducer Ratio							
	15	20	25	30	40	50	60

Contact your DESTACO sales representative for more information.

Features

- R180 Reducer (Ratios from 15:1 to 60:1)
 - Double Extended Worm Shaft (Input)
 - Worm Shaft Handwheel
- Double Extended Camshaft (Input Shaft)
- Center Thru Hole (Ø70 mm [Ø2.76 in.])
- 1/3 HP AC Drive Package with Inverter Duty Motor and IM-pAC AC Drive (up to 60 cpm)
- Cycle Cam and Limit Switch Mounted to Camshaft
- Right Hand Cam
- Universal Mounting Capability

Output Load Capacity (loads carried during index):

Radial	3358 N [755 lbs]
Thrust/Axial	8385 N [1885 lbs]
Moment	213 N-m [1885 in-lb]

Typical Application Dial Diameter:

203 mm [8 in] to 711 mm [28 in]

Accuracy

±44 arcsec / ±0,08 mm [±.003in] at 355,6 mm [14in] Radius

Repeatability

±11 arcsec / ±0,018 mm [±.0007in] at 355,6 mm [14in] Radius

Optional Accessories

- 1/3 HP DC Motor
- Varipak DC Motor Control (up to 30 cpm)
- Output Mechanical Overload Clutch
 - See Page 9
- EZ Mount Dial Adapter
- Stationary Center Post
- Dual Cam and Limit Switch
- Electric Clutch-Brake
- Left Hand Cam

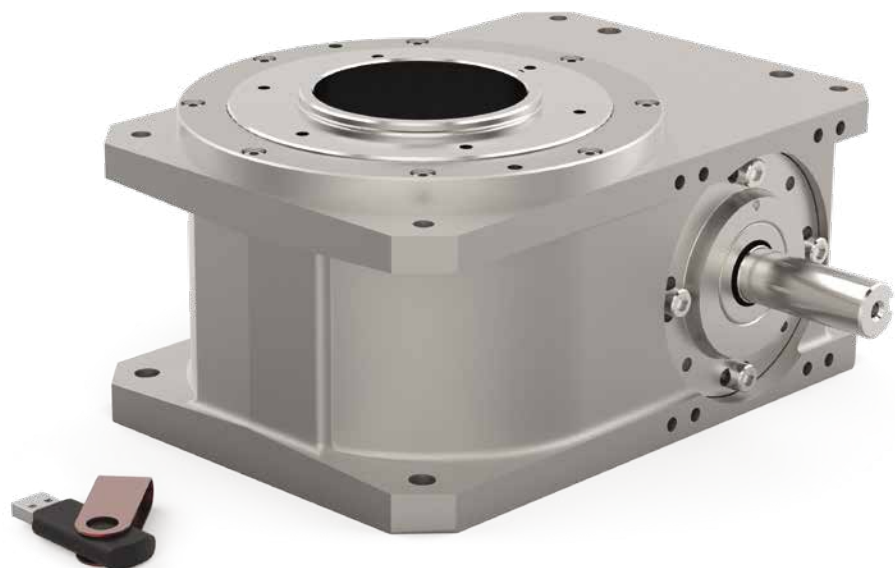

8ORDM SERIES

Rotary Index Drive | Dimensions

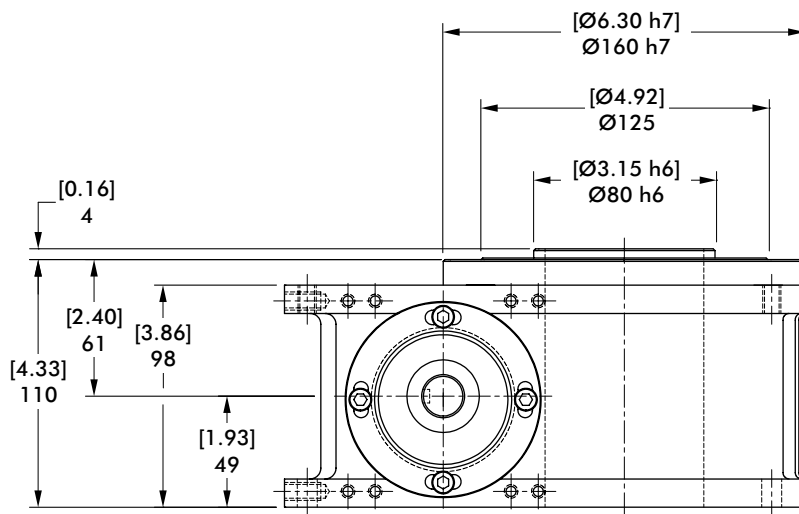
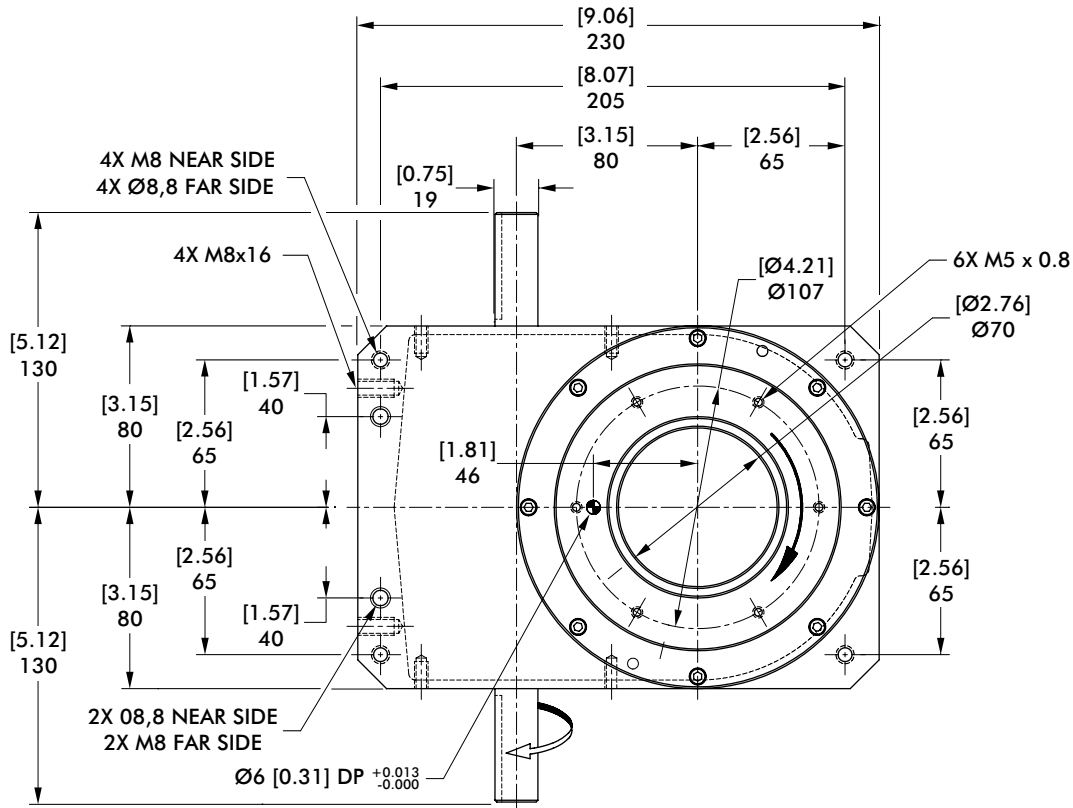
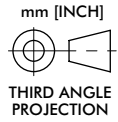

8ORDM SERIES

Rotary Index Drive | Product Overview | Technical Specifications

Proximity Switch

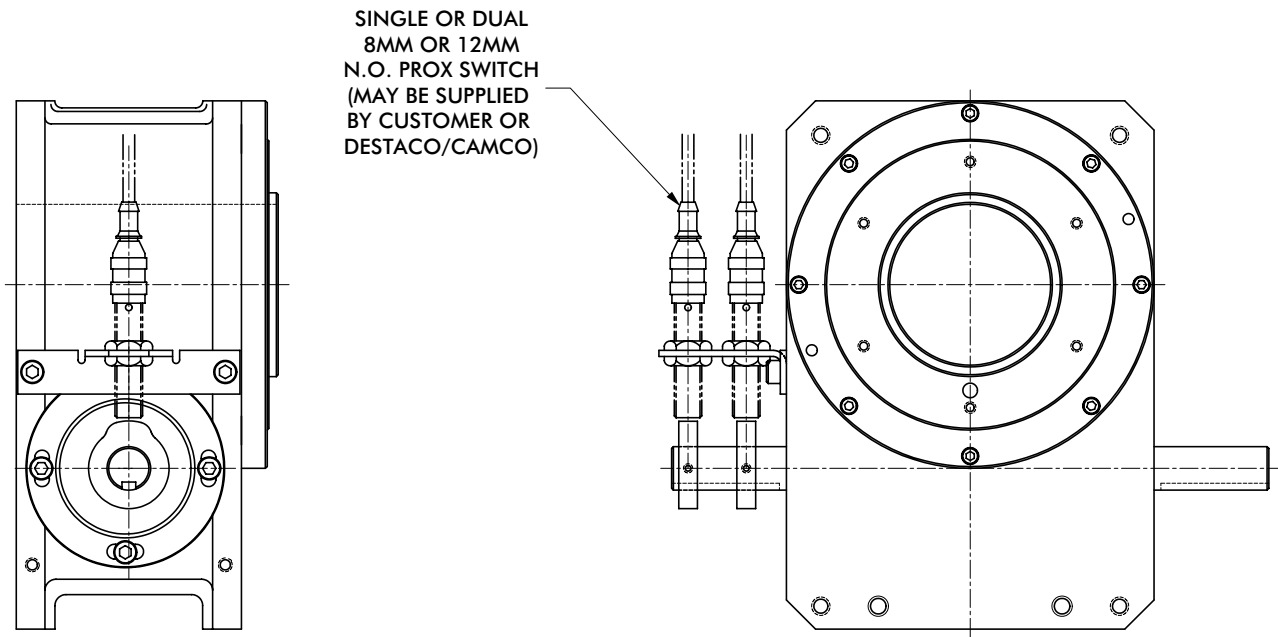

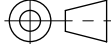
mm [INCH]

 THIRD ANGLE
 PROJECTION

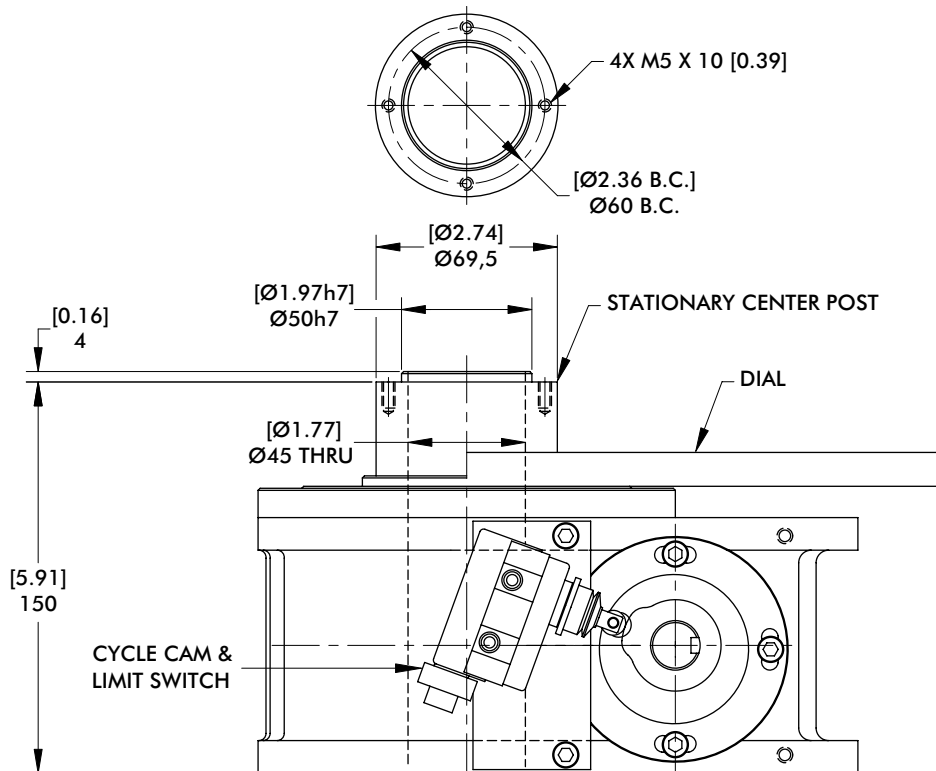
Center Post



8ORDM SERIES

Rotary Index Drive | Dimensions

2.8D Overload Clutch

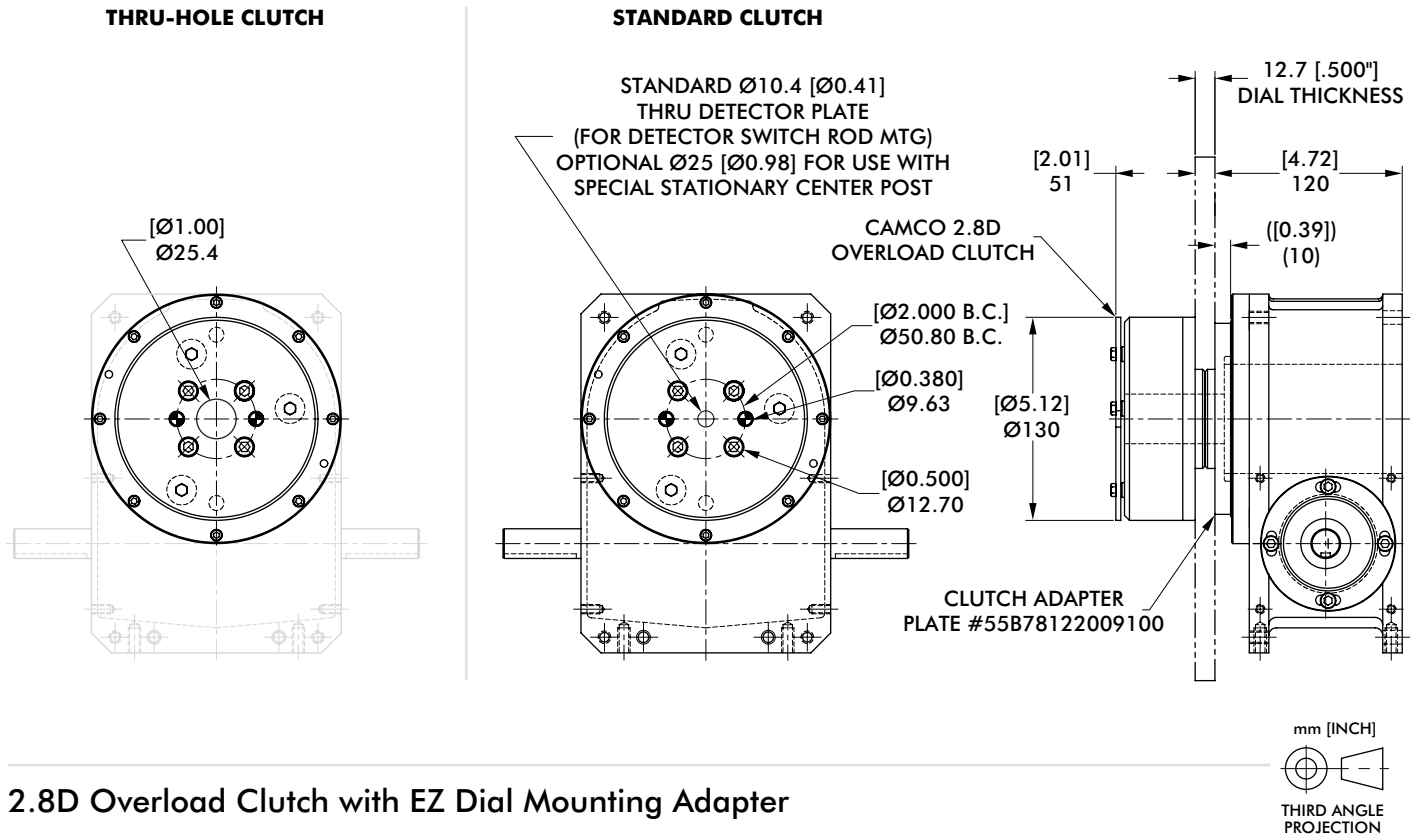

2.8D Overload Clutch with EZ Dial Mounting Adapter

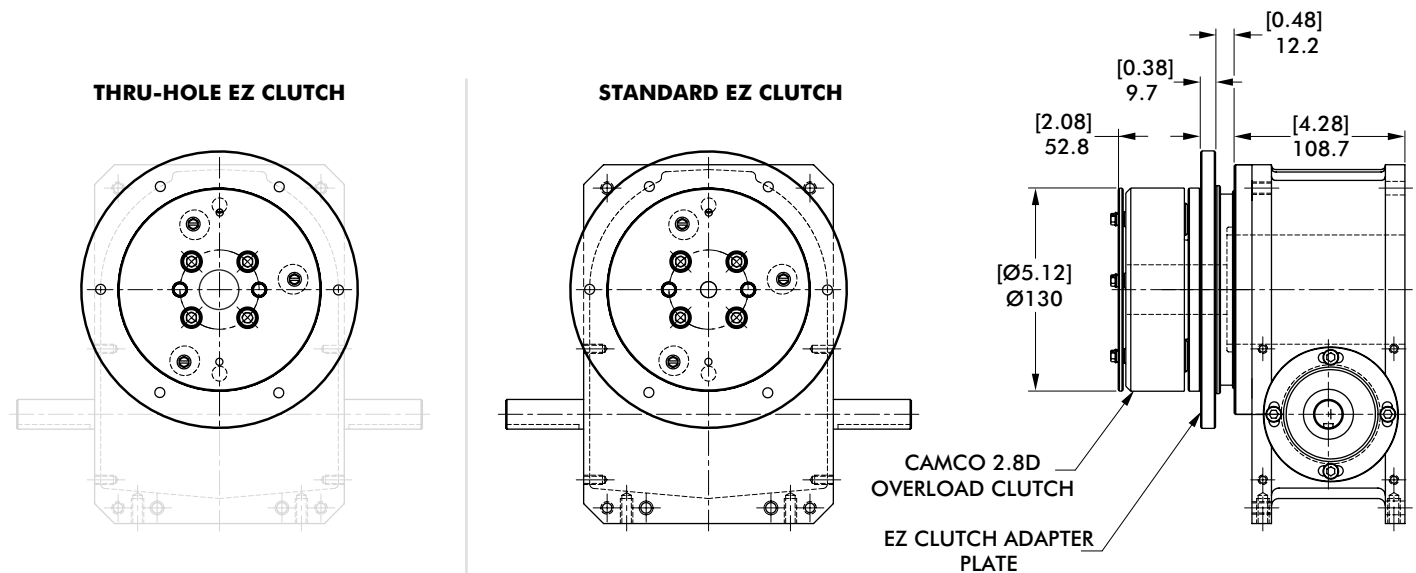

Model	Internal Inertia kg-m ² [lb-in ²]	Torque Setting N-m [in-lb]
2.8D	0,0085 [29]	45, 54, 79, 96, 124, 147, 203, 249, 350 [400, 480, 700, 850, 1100, 1300, 1800, 2200, 3100]

80RDM SERIES

Notes

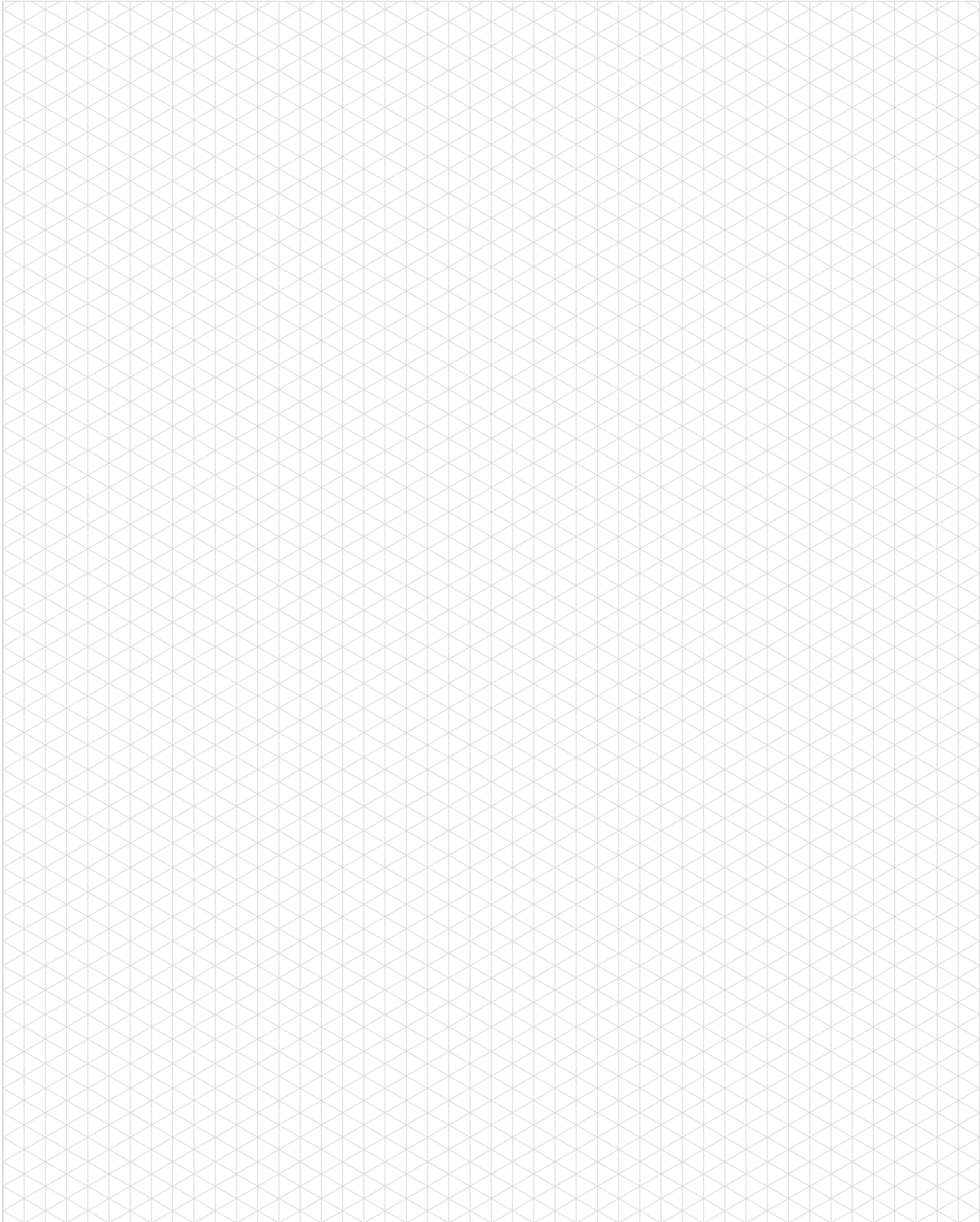

601RDM SERIES

Rotary Index Drive | How To Order

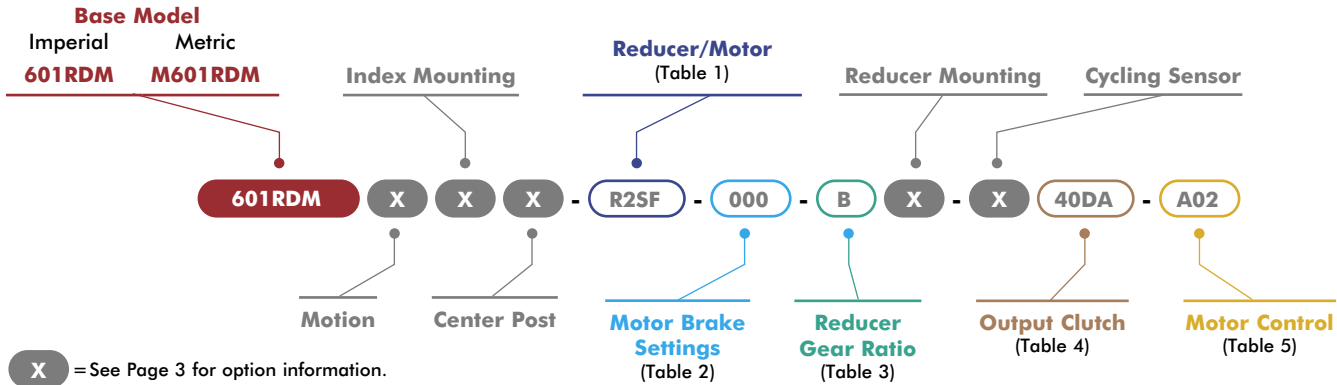

1 Reducer/Motor Options

Code	Description
0000	No Reducer or Motor*
R180/R225 Motors	
R18X	R180 Adapter only*
R18A	R180 Reducer
R18B	R180 Reducer with 0.33HP 230/460V AC Motor
R18C	R180 Reducer with 0.33HP 90V DC Motor
R18D	R180 Reducer with 0.33HP 180V DC Motor
R2XX	R225 Adapter only*
R2SA	R225 Reducer 56 ADAPTER & CPLG, Single Extended Worm
R2SB	R225 Reducer 145TC ADAPTER & CPLG, Single Extended Worm (No Motor)
R2SC	R225 Reducer with 0.5HP 56C 230/460V AC Motor, Single Extended Worm
R2SD	R225 Reducer with 1.0HP 56C 230/460V AC Motor, Single Extended Worm
R2SE	R225 Reducer with 1.0HP 56C 90V DC Motor, Single Extended Worm
R2SF	R225 Reducer with 1.0HP 56C 180V DC Motor, Single Extended Worm
R2DA	R225 Reducer 56 ADAPTER & CPLG, Double Extended Worm
R2DB	R225 Reducer 145TC ADAPTER & CPLG, Double Extended Worm (No Motor)
R2DC	R225 Reducer with 0.5HP 56C 230/460V AC Motor, Double Extended Worm
R2DD	R225 Reducer with 1.0HP 56C 230/460V AC Motor, Double Extended Worm
R2DE	R225 Reducer with 1.0HP 56C 90V DC Motor, Double Extended Worm
R2DF	R225 Reducer with 1.0HP 56C 180V DC Motor, Double Extended Worm
SEW KH37 Motors	
SW1A	KH37 Adapter only*
SW1B	SEW KH37DRS71S4 0.25Kw Motor (60Hz, 230/460V)
SW1C	SEW KH37DRS71S4 0.25Kw Motor (50Hz, 400V)
SW1D	SEW KH37DRS71S4 0.25Kw Motor (60Hz, 575V)
SW1E	SEW KH37DRS71S4 0.37Kw Motor (60Hz, 230/460V)
SW1F	SEW KH37DRS71S4 0.37Kw Motor (50Hz, 400V)
SW1G	SEW KH37DRS71S4 0.37Kw Motor (60Hz, 575V)
STM RMI-40/50 Motors	
RM2A	STM RMI-40 Adapter only*
RM2B	STM RMI-40 IEC63-B14 Reducer
RM2C	STM RMI-40 IEC71-B14 Reducer
RM2D	STM RMI-40 Reducer w/ 0.18kW Motor
RM2E	STM RMI-40 Reducer w/ 0.25kW Motor
RM3A	STM RMI-50 Adapter only*
RM3B	STM RMI-50 IEC71-B14 Reducer
RM3C	STM RMI-50 IEC80-B14 Reducer
RM3D	STM RMI-50 Reducer w/ 0.37Kw Motor
RM3E	STM RMI-50 Reducer w/ 0.55kW Motor

*All Reducer/Motor adapters require Gear Ratio option to be 0.

2 Motor Brake

Code	Description
000	No Brake
S1A	1.69 Nm (BE05)
S1B	2.49 Nm (BE05)
S1C	3.50 Nm (BE05)
S2A	4.97 Nm (BE1)
S2B	7.01 Nm (BE1)
S2C	9.94 Nm (BE1)

*SEW Motor brake setting options only. All other motors use option code 000.

3 Reducer Gear Ratios

Code	Description		
	R180/225	SEW KH37	STM RMI-40/50
0	N/A	N/A	N/A
A	10:1	10.49:1	10:1
B	15:1	15.31:1	15:1
C	20:1	20.19:1	20:1
D	25:1	29.96:1	28:1
E	30:1	37.97:1	40:1
F	40:1	49.79:1	49:1
G	50:1	58.60:1	56:1
H	60:1	67.80:1	70:1

*All Reducer/Motor adapters require Gear Ratio option to be 0.
Select Gear ratio column based on the reducer type selected.

4 Output Clutch & Settings

601RDM Imperial Clutch Models		M601RDM Metric Clutch Models	
Code	Description	Code	Description
0000	No Output Overload Clutch	0000	No Output Overload Clutch
40DA	4.0D/420 In-Lb, Standard*	M40DA	M4.0D/47 Nm, Standard*
40DB	4.0D/620 In-Lb, Standard*	M40DB	M4.0D/70 Nm, Standard*
40DC	4.0D/750 In-Lb, Standard*	M40DC	M4.0D/85 Nm, Standard*
40DD	4.0D/1150 In-Lb, Standard*	M40DD	M4.0D/130 Nm, Standard*
40DE	4.0D/1750 In-Lb, Standard*	M40DE	M4.0D/198 Nm, Standard*
40DF	4.0D/2950 In-Lb, Standard*	M40DF	M4.0D/333 Nm, Standard*
40DG	4.0D/4000 In-Lb, Standard*	M40DG	M4.0D/452 Nm, Standard*
40DH	4.0D/420 In-Lb, Thru-Hole	M40DH	M4.0D/47 Nm, Thru-Hole
40DJ	4.0D/620 In-Lb, Thru-Hole	M40DJ	M4.0D/70 Nm, Thru-Hole
40DK	4.0D/750 In-Lb, Thru-Hole	M40DK	M4.0D/85 Nm, Thru-Hole
40DL	4.0D/1150 In-Lb, Thru-Hole	M40DL	M4.0D/130 Nm, Thru-Hole
40DM	4.0D/1750 In-Lb, Thru-Hole	M40DM	M4.0D/198 Nm, Thru-Hole
40DN	4.0D/2950 In-Lb, Thru-Hole	M40DN	M4.0D/333 Nm, Thru-Hole
40DP	4.0D/4000 In-Lb, Thru-Hole	M40DP	M4.0D/452 Nm, Thru-Hole
40EA	4.0D/420 In-Lb, Standard, EZ*	M40EA	M4.0D/47 Nm, Standard, EZ*
40EB	4.0D/620 In-Lb, Standard, EZ*	M40EB	M4.0D/70 Nm, Standard, EZ*
40EC	4.0D/750 In-Lb, Standard, EZ*	M40EC	M4.0D/85 Nm, Standard, EZ*
40ED	4.0D/1150 In-Lb, Standard, EZ*	M40ED	M4.0D/130 Nm, Standard, EZ*
40EE	4.0D/1750 In-Lb, Standard, EZ*	M40EE	M4.0D/198 Nm, Standard, EZ*
40EF	4.0D/2950 In-Lb, Standard, EZ*	M40EF	M4.0D/333 Nm, Standard, EZ*
40EG	4.0D/4000 In-Lb, Standard, EZ*	M40EG	M4.0D/452 Nm, Standard, EZ*
40EH	4.0D/420 In-Lb, Thru-Hole, EZ	M40EH	M4.0D/47 Nm, Thru-Hole, EZ
40EJ	4.0D/620 In-Lb, Thru-Hole, EZ	M40EJ	M4.0D/70 Nm, Thru-Hole, EZ
40EK	4.0D/750 In-Lb, Thru-Hole, EZ	M40EK	M4.0D/85 Nm, Thru-Hole, EZ
40EL	4.0D/1150 In-Lb, Thru-Hole, EZ	M40EL	M4.0D/130 Nm, Thru-Hole, EZ
40EM	4.0D/1750 In-Lb, Thru-Hole, EZ	M40EM	M4.0D/198 Nm, Thru-Hole, EZ
40EN	4.0D/2950 In-Lb, Thru-Hole, EZ	M40EN	M4.0D/333 Nm, Thru-Hole, EZ
40EP	4.0D/4000 In-Lb, Thru-Hole, EZ	M40EP	M4.0D/452 Nm, Thru-Hole, EZ

*Cannot be used with center post option P.

5 Motor Control

Code	Description
000	NO MOTOR CONTROL
A01	120V 1Ph
A02	240V 1Ph
A03	480V 3Ph
A04	120V 1Ph
A05	240V 1Ph
A06	480V 3Ph
A07	240V 3Ph
A08	480V 3Ph
A09	240V 3Ph
A10	480V 3Ph
D01	Uni-Directional
D02	Bi-Directional
D03	Uni-Directional
D04	Bi-Directional

Maximum Inertia x 1000 kg-cm ² [lb-in ²] for standard package							
Stops	Motion Time [seconds]						
	0.458	0.611	0.764	0.917	1.222	1.528	1.833
2	0 [0]	3 [1]	6 [2]	15 [5]	32 [11]	50 [17]	70 [24]
3	3 [1]	9 [3]	20 [7]	35 [12]	82 [28]	123 [42]	170 [58]
4	6 [2]	18 [6]	38 [13]	67 [23]	152 [52]	228 [78]	310 [106]
6	15 [5]	41 [14]	82 [28]	149 [51]	328 [112]	492 [168]	667 [228]
8	29 [10]	73 [25]	149 [51]	263 [90]	582 [199]	875 [299]	1188 [406]
12	64 [22]	167 [57]	337 [115]	597 [204]	1314 [449]	1399 [478]	1399 [478]
16	117 [40]	296 [101]	600 [205]	1056 [361]	1399 [478]	1399 [478]	1399 [478]
Reducer Ratio							
	15	20	25	30	40	50	60

Other Motions (stops and index periods) available. Contact your DESTACO sales representative for more information.

Features

- R180 Reducer (Ratios from 15:1 to 60:1)
 - Double Extended Worm Shaft (Input)
 - Worm Shaft Handwheel
- Double Extended Camshaft (Input Shaft)
- Center Thru Hole (Ø44,45 [Ø1.75 in.])
- 1/3 HP AC Drive Package with Inverter Duty Motor and IM-pAC AC Drive (up to 60 cpm)
- Cycle Cam and Limit Switch Mounted to Camshaft
- Right Hand Cam

Output Load Capacity (loads carried during index):

Radial	4204 N [945 lbs]
Thrust/Axial	10498 N [2360 lbs]
Moment	373 N-m [3305 in-lb]

Typical Application

Dial Diameter: 305 mm [12 in] to 914 mm [36 in]

Accuracy ±39 arcsec / ±0,08 mm [±.003in] at 457,2 mm [18in] Radius

Repeatability ±10 arcsec / ±0,023 mm [±.0009in] at 457,2 mm [18in] Radius

Optional Accessories

- 1/3 hp DC Motor
- Varipak DC Motor Control (up to 30 cpm)
- Output Mechanical Overload Clutch
 - See Page 15
- EZ Mount Dial Adapter
- Stationary Center Post
- Dual Cam and Limit Switch
- Relief in Dwell for shot-pin applications
- Left Hand Cam



601RDM SERIES

Rotary Index Drive | Dimensions

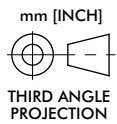
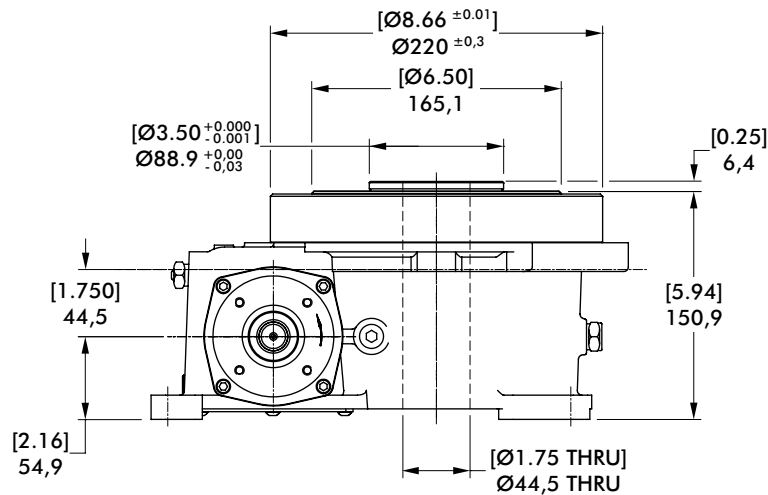
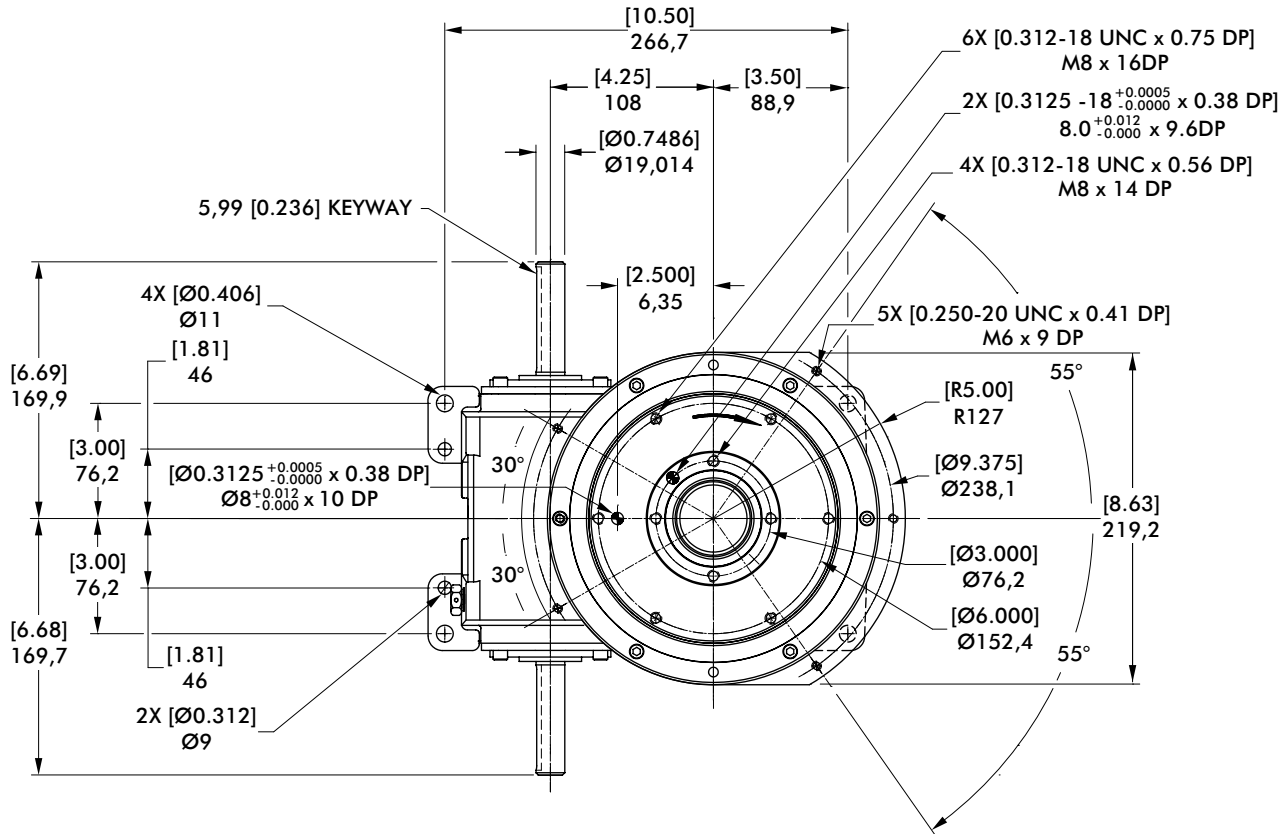

601RDM SERIES

Rotary Index Drive | Dimensions

Proximity Switch

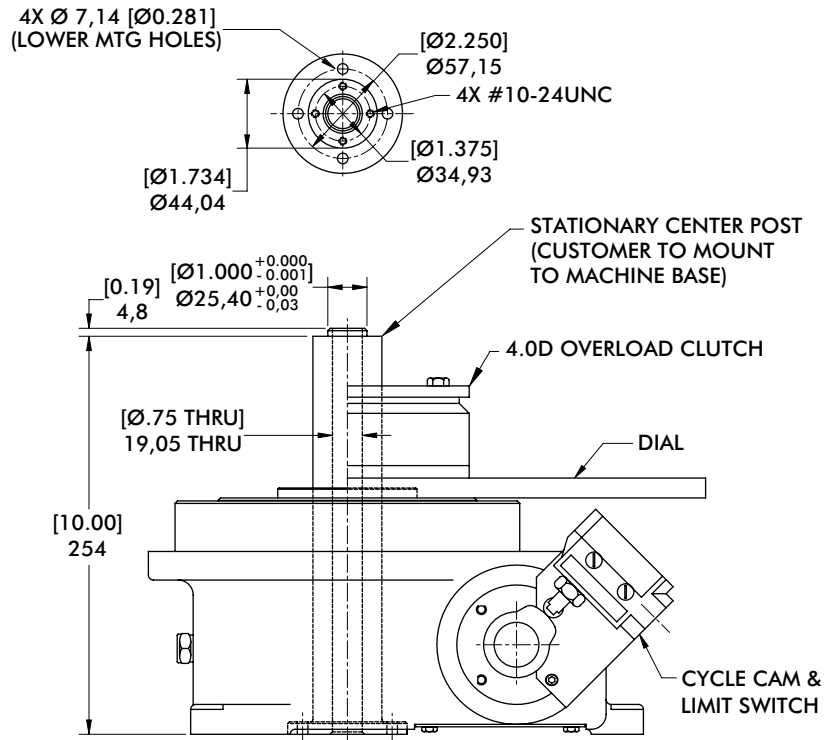

mm [INCH]

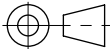

THIRD ANGLE
PROJECTION

Center Post

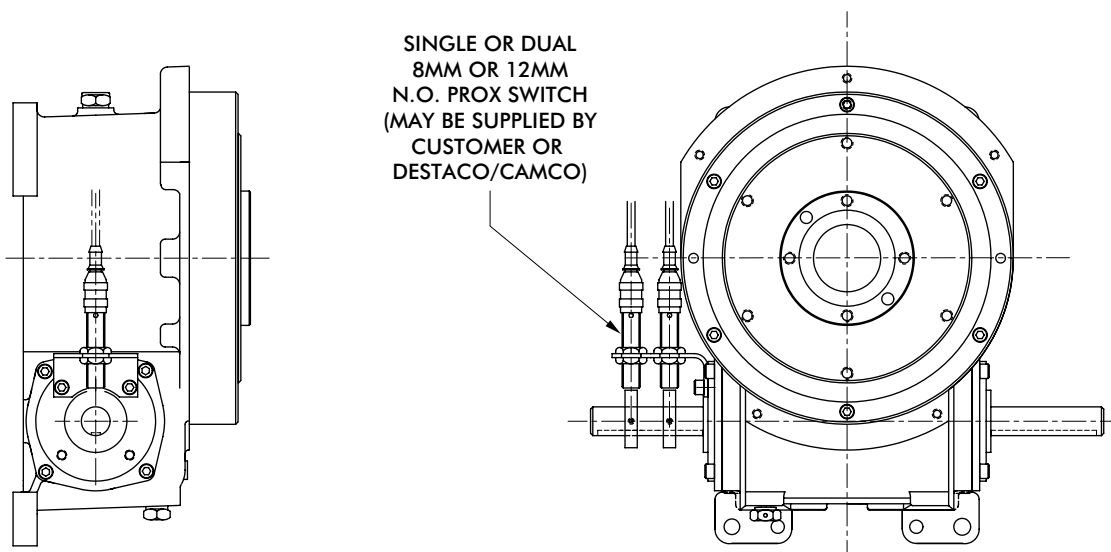

601RDM SERIES

Rotary Index Drive | Dimensions

4.0D Overload Clutch

THRU-HOLE CLUTCH

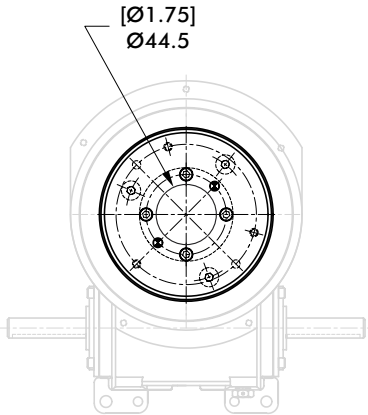

STANDARD CLUTCH

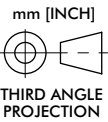
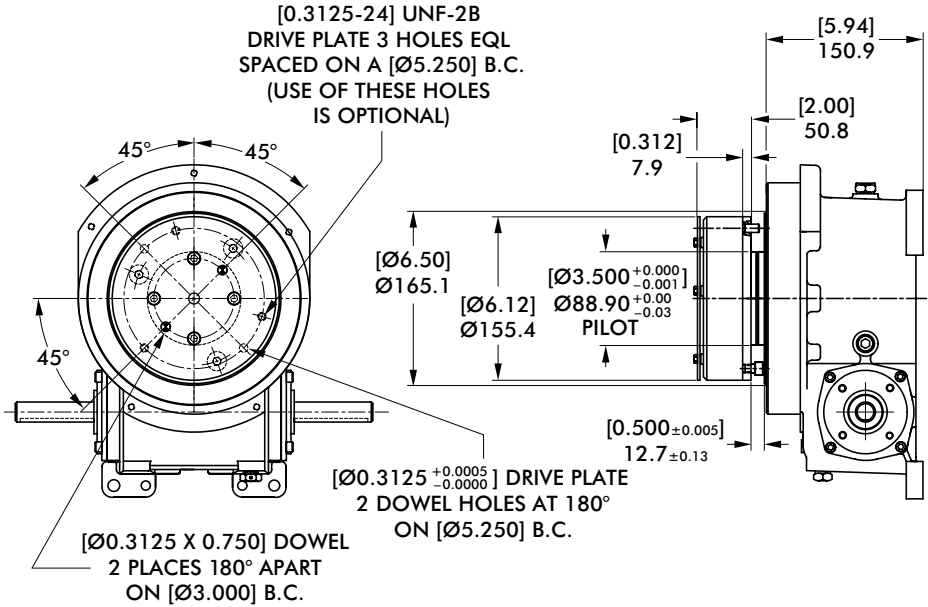

4.0D Overload Clutch with EZ Dial Mounting Adapter

THRU-HOLE EZ CLUTCH

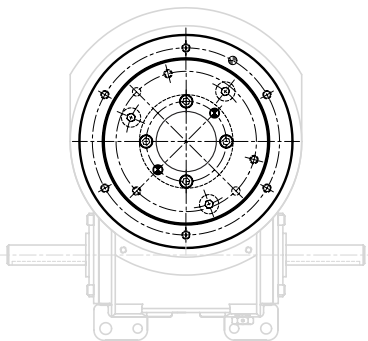

STANDARD EZ CLUTCH

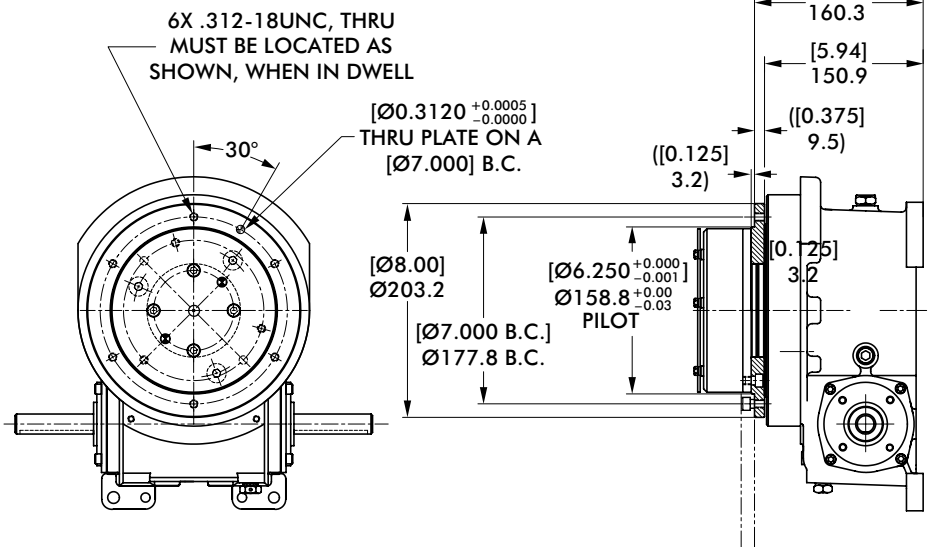

Model	Internal Inertia kg-m ² [lb-in ²]	Torque Setting N-m [in-lb]
4.0D	0,0202 [69]	47, 70, 85, 130, 198, 333, 452 [420, 620, 750, 1150, 1750, 2950, 4000]

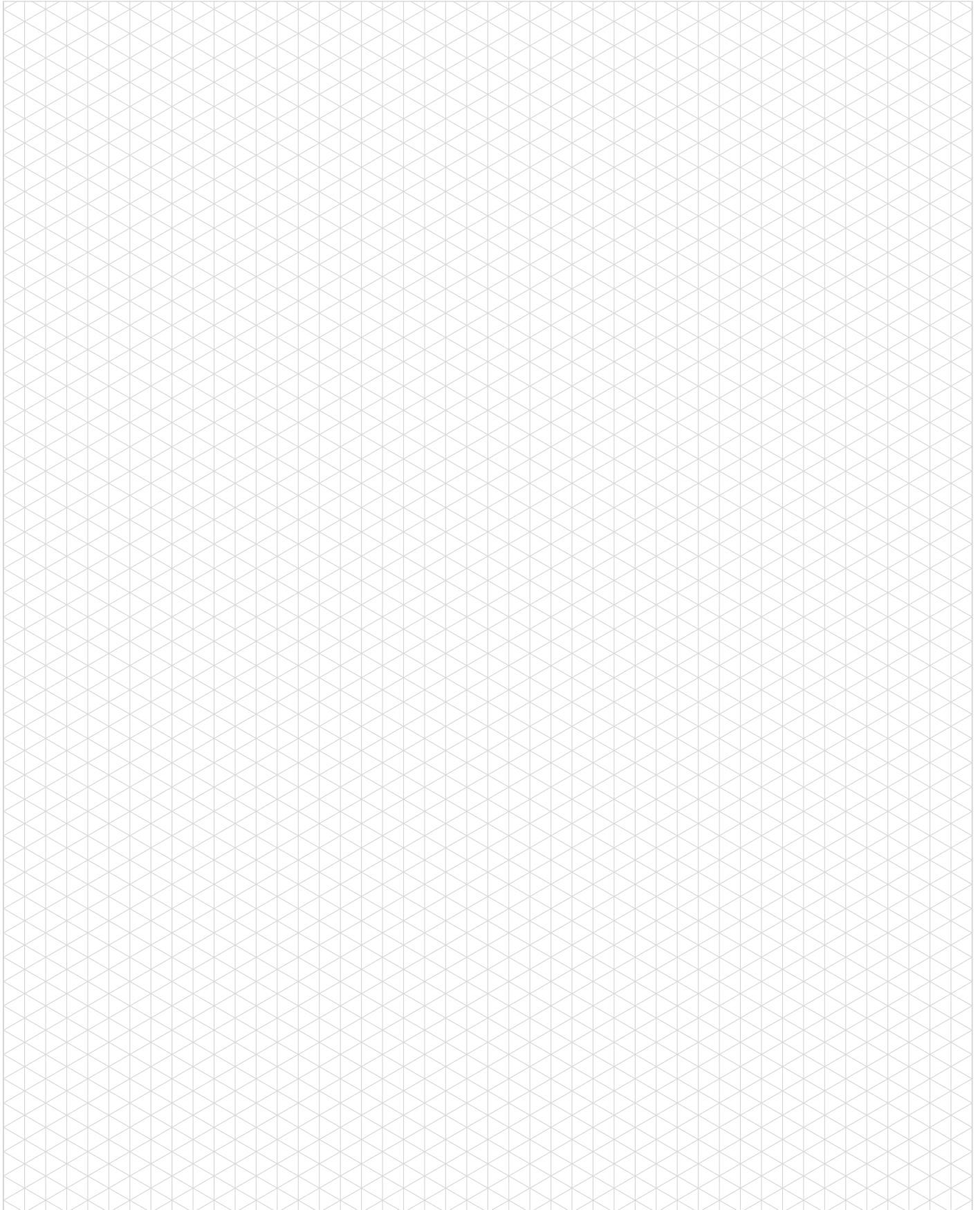

902RDM SERIES

Rotary Index Drive | How To Order

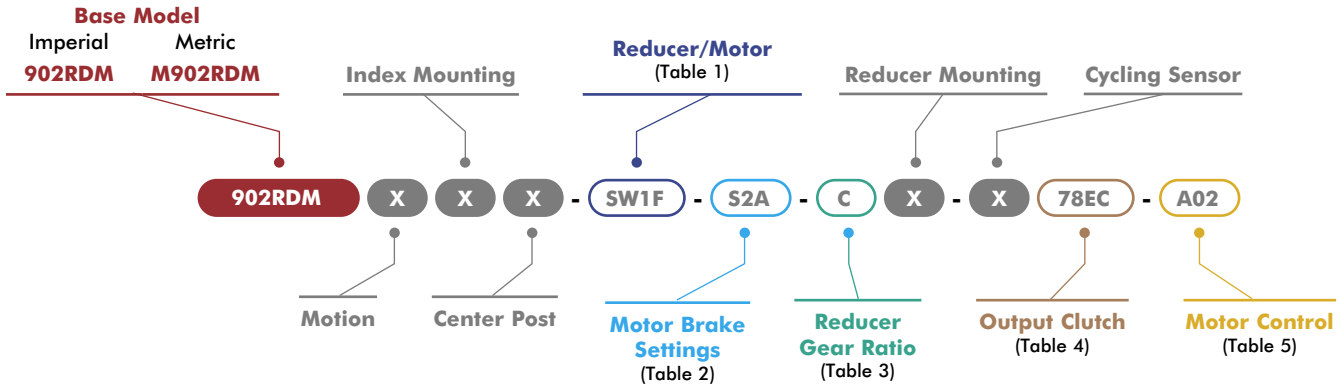

X = See Page 3 for option information.

1 Reducer/Motor Options

Code	Description
0000	No Reducer or Motor*
R225 Motors	
R2XX	R225 Adapter only*
R2SA	R225 Reducer 56 ADAPTER & CPLG, Single Extended Worm
R2SB	R225 Reducer 145TC ADAPTER & CPLG, Single Extended Worm (No Motor)
R25C	R225 Reducer with 0.5HP 56C 230/460V AC Motor, Single Extended Worm
R2SD	R225 Reducer with 1.0HP 56C 230/460V AC Motor, Single Extended Worm
R2SE	R225 Reducer with 1.0HP 56C 90V DC Motor, Single Extended Worm
R25F	R225 Reducer with 1.0HP 56C 180V DC Motor, Single Extended Worm
R2DA	R225 Reducer 56 ADAPTER & CPLG, Double Extended Worm
R2DB	R225 Reducer 145TC ADAPTER & CPLG, Double Extended Worm (No Motor)
R2DC	R225 Reducer with 0.5HP 56C 230/460V AC Motor, Double Extended Worm
R2DD	R225 Reducer with 1.0HP 56C 230/460V AC Motor, Double Extended Worm
R2DE	R225 Reducer with 1.0HP 56C 90V DC Motor, Double Extended Worm
R2DF	R225 Reducer with 1.0HP 56C 180V DC Motor, Double Extended Worm
SEW KH37 Motors	
SW1E	KH37 Adapter only*
SW1F	SEW KH37DRN80M4/.75Kw Motor/Brake Motor (60Hz, 230/460V)
SW1G	SEW KH37DRN80M4/.75Kw Motor/Brake Motor (50Hz, 400V)
SW1H	SEW KH37DRN80M4/.75Kw Motor/Brake Motor (60Hz, 575V)
SW1J	SEW KH37DRN90L4/1.5Kw Motor/Brake Motor (60Hz, 230/460V)
SW1K	SEW KH37DRN90L4/1.5Kw Motor/Brake Motor (50Hz, 400V)
SW1L	SEW KH37DRN90L4/1.5Kw Motor/Brake Motor (60Hz, 575V)
STM RMI-63/70 Motors	
RM4A	STM RMI-63 Adapter only*
RM4B	STM RMI-63 IEC80-B14 Reducer
RM4C	STM RMI-63 IEC90-B14 Reducer
RM4D	STM RMI-63 Reducer with .75kW Motor
RM4E	STM RMI-63 Reducer with 1.5kW Motor
RM5A	STM RMI-70 Adapter only*
RM5B	STM RMI-70 IEC80-B14 Reducer
RM5C	STM RMI-70 IEC90-B14 Reducer
RM5D	STM RMI-70 Reducer with .75kW Motor
RM5E	STM RMI-70 Reducer with 1.5kW Motor

*All Reducer/Motor adapters require Gear Ratio option to be 0.

2 Motor Brake*

Code	Description
000	No Brake
S1A	1.69 Nm (BE05)
S1B	2.49 Nm (BE05)
S1C	3.50 Nm (BE05)
S2A	4.97 Nm (BE1)
S2B	7.01 Nm (BE1)
S2C	9.94 Nm (BE1)
S3A	9.94 Nm (BE2)
S3B	14.01 Nm (BE2)
S3C	20.00 Nm (BE2)

*SEW Motor brake setting options only. All other motors use option code 000.

3 Reducer Gear Ratios*

Code	Description	R225	SEW KH37	STM RMI-63/70
0	N/A	N/A	N/A	N/A
A	10:1	10.49:1	10:1	
B	15:1	15.31:1	15:1	
C	20:1	20.19:1	20:1	
D	25:1	29.96:1	28:1	
E	30:1	37.97:1	40:1	
F	40:1	49.79:1	49:1	
G	50:1	58.60:1	56:1	
H	60:1	67.80:1	70:1	

*All Reducer/Motor adapters require Gear Ratio option to be 0.
Select Gear ratio column based on the reducer type selected.

4 Output Clutch & Settings

902RDM Imperial Clutch Models		M902RDM Metric Clutch Models	
Code	Description	Code	Description
0000	No Output Overload Clutch	0000	No Output Overload Clutch
78DA	7.8D/3200 In-Lb, Standard*	M78DA	M7.8D/360 Nm, Standard*
78DB	7.8D/7200 In-Lb, Standard*	M78DB	M7.8D/815 Nm, Standard*
78DC	7.8D/10000 In-Lb, Standard*	M78DC	M7.8D/1130 Nm, Standard*
78DD	7.8D/1400 In-Lb, Standard*	M78DD	M7.8D/160 Nm, Standard*
78DE	7.8D/1700 In-Lb, Standard*	M78DE	M7.8D/192 Nm, Standard*
78DF	7.8D/2600 In-Lb, Standard*	M78DF	M7.8D/295 Nm, Standard*
78DG	7.8D/4200 In-Lb, Standard*	M78DG	M7.8D/475 Nm, Standard*
78DH	7.8D/5000 In-Lb, Standard*	M78DH	M7.8D/566 Nm, Standard*
78DJ	7.8D/3200 In-Lb, Thru-Hole	M78DJ	M7.8D/360 Nm, Thru-Hole
78DK	7.8D/7200 In-Lb, Thru-Hole	M78DK	M7.8D/815 Nm, Thru-Hole
78DL	7.8D/10000 In-Lb, Thru-Hole	M78DL	M7.8D/1130 Nm, Thru-Hole
78DM	7.8D/1400 In-Lb, Thru-Hole	M78DM	M7.8D/160 Nm, Thru-Hole
78DN	7.8D/1700 In-Lb, Thru-Hole	M78DN	M7.8D/192 Nm, Thru-Hole
78DP	7.8D/2600 In-Lb, Thru-Hole	M78DP	M7.8D/295 Nm, Thru-Hole
78DQ	7.8D/4200 In-Lb, Thru-Hole	M78DQ	M7.8D/475 Nm, Thru-Hole
78DR	7.8D/5000 In-Lb, Thru-Hole	M78DR	M7.8D/566 Nm, Thru-Hole
78EA	7.8D/3200 In-Lb, Standard, EZ*	M78EA	M7.8D/360 Nm, Standard, EZ*
78EB	7.8D/7200 In-Lb, Standard, EZ*	M78EB	M7.8D/815 Nm, Standard, EZ*
78EC	7.8D/10000 In-Lb, Standard, EZ*	M78EC	M7.8D/1130 Nm, Standard, EZ*
78ED	7.8D/1400 In-Lb, Standard, EZ*	M78ED	M7.8D/160 Nm, Standard, EZ*
78EE	7.8D/1700 In-Lb, Standard, EZ*	M78EE	M7.8D/192 Nm, Standard, EZ*
78EF	7.8D/2600 In-Lb, Standard, EZ*	M78EF	M7.8D/295 Nm, Standard, EZ*
78EG	7.8D/4200 In-Lb, Standard, EZ*	M78EG	M7.8D/475 Nm, Standard, EZ*
78EH	7.8D/5000 In-Lb, Standard, EZ*	M78EH	M7.8D/566 Nm, Standard, EZ*
78EJ	7.8D/3200 In-Lb, Thru-Hole, EZ	M78EJ	M7.8D/360 Nm, Thru-Hole, EZ
78EK	7.8D/7200 In-Lb, Thru-Hole, EZ	M78EK	M7.8D/815 Nm, Thru-Hole, EZ
78EL	7.8D/10000 In-Lb, Thru-Hole, EZ	M78EL	M7.8D/1130 Nm, Thru-Hole, EZ
78EM	7.8D/1400 In-Lb, Thru-Hole, EZ	M78EM	M7.8D/160 Nm, Thru-Hole, EZ
78EN	7.8D/1700 In-Lb, Thru-Hole, EZ	M78EN	M7.8D/192 Nm, Thru-Hole, EZ
78EP	7.8D/2600 In-Lb, Thru-Hole, EZ	M78EP	M7.8D/295 Nm, Thru-Hole, EZ
78EQ	7.8D/4200 In-Lb, Thru-Hole, EZ	M78EQ	M7.8D/475 Nm, Thru-Hole, EZ
78ER	7.8D/5000 In-Lb, Thru-Hole, EZ	M78ER	M7.8D/566 Nm, Thru-Hole, EZ

*Cannot be used with center post options P and B.

5 Motor Control

Code	Description
000	NO MOTOR CONTROL
A01	120V 1Ph
A02	(AC) PowerFlex 523 1HP
A03	240V 1Ph
A04	480V 3Ph
A05	120V 1Ph
A06	(AC) PowerFlex 525 1HP
A07	240V 1Ph
A08	480V 3Ph
A09	(AC) PowerFlex 523 2HP
A10	240V 3Ph
A11	(AC) PowerFlex 525 2HP
A12	480V 3Ph
D01	Uni-Directional
D02	(DC) Varipak 1HP 90VDC
D03	Bi-Directional
D04	(DC) Varipak 2HP 180VDC
D05	Uni-Directional
D06	Bi-Directional

Maximum Inertia x 1000 kg-cm ² [lb-in ²] for standard package							
Stops	Motion Time [seconds]						
	0.458	0.611	0.764	0.917	1.222	1.528	1.833
2	3 [1]	9 [3]	20 [7]	35 [12]	76 [26]	117 [40]	161 [55]
3	12 [4]	32 [11]	67 [23]	120 [41]	246 [84]	369 [126]	509 [174]
4	23 [8]	59 [20]	120 [41]	214 [73]	439 [150]	661 [226]	907 [310]
6	53 [18]	129 [44]	263 [90]	462 [158]	945 [323]	1419 [485]	1952 [667]
8	94 [32]	234 [80]	468 [160]	825 [282]	1683 [575]	2528 [864]	3474 [1187]
12	214 [73]	530 [181]	989 [338]	1425 [487]	2531 [865]	3956 [1352]	5701 [1948]
16	380 [130]	916 [313]	1481 [506]	2130 [728]	3790 [1295]	5923 [2024]	8528 [2914]
Reducer Ratio							
	15	20	25	30	40	50	60

Other Motions (stops and index periods) available. Contact your DESTACO sales representative for more information.

Features

- R225 Reducer (Ratios from 15:1 to 60:1)
- Single Extended wormshaft (Standard)
- Double Extended Camshaft (Input Shaft)
- Center Thru Hole (Ø57,15 mm [Ø2.25 in.])
- 1 HP AC Drive Package with Inverter Duty Motor and IM-pAC AC Drive (up to 60 cpm)
- Cycle Cam and Limit Switch Mounted to Camshaft
- Right Hand Cam

Output Load Capacity (loads carried during index):

Radial	15747 N [3540 lbs]
Thrust/Axial	31138 N [7000 lbs]
Moment	2443 N-m [21620 in-lb]

Typical Application Dial Diameter:

508 mm [20 in] to 1219 mm [48 in]

Accuracy

±27 arcsec / ±0,08 mm [±.003in]
at 609,6 mm [24in] Radius

Repeatability

±7 arcsec / ±0,020 mm [±.0008in]
at 609,6 mm [24in] Radius

Optional Accessories

- 1 hp DC Motor
- Varipak DC Motor Control (up to 30 cpm)
- Output Mechanical Overload Clutch
– See Page 21
- EZ Mount Dial Adapter
- Stationary Center Post
- Dual Cam and Limit Switch
- Base Riser Blocks
- Electric Clutch-Brake
- Left Hand Cam
- Relief in Dwell for shot-pin applications



902RDM SERIES

Rotary Index Drive | Dimensions

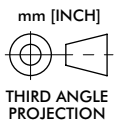
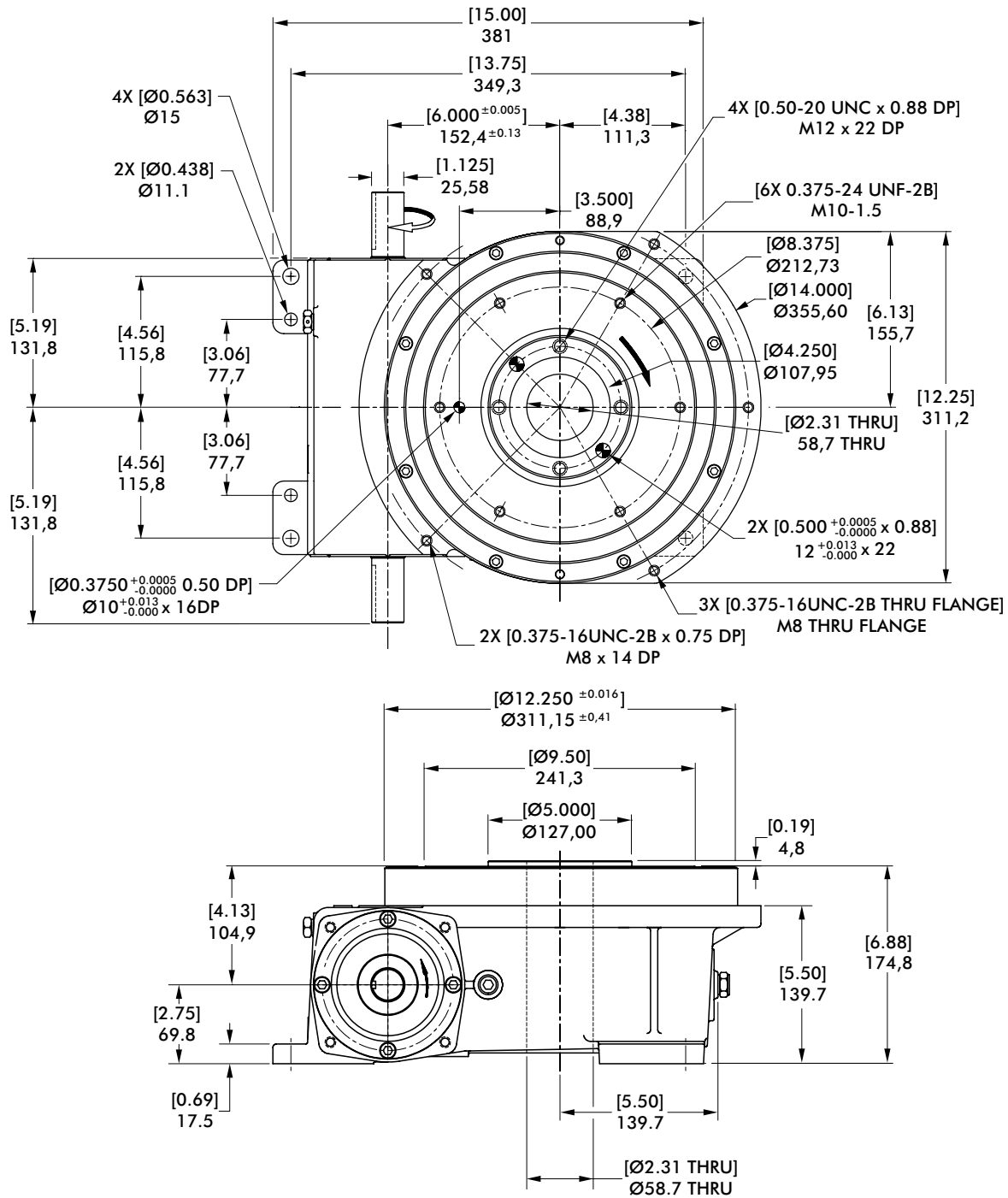

902RDM SERIES

Rotary Index Drive | Product Overview | Technical Specifications

Center Post

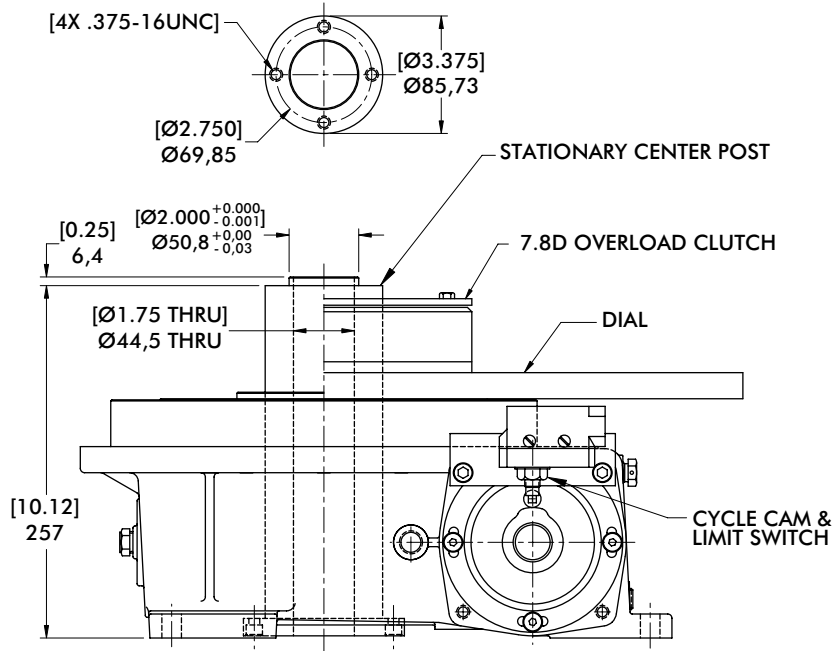

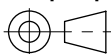
mm [INCH]

 THIRD ANGLE
 PROJECTION

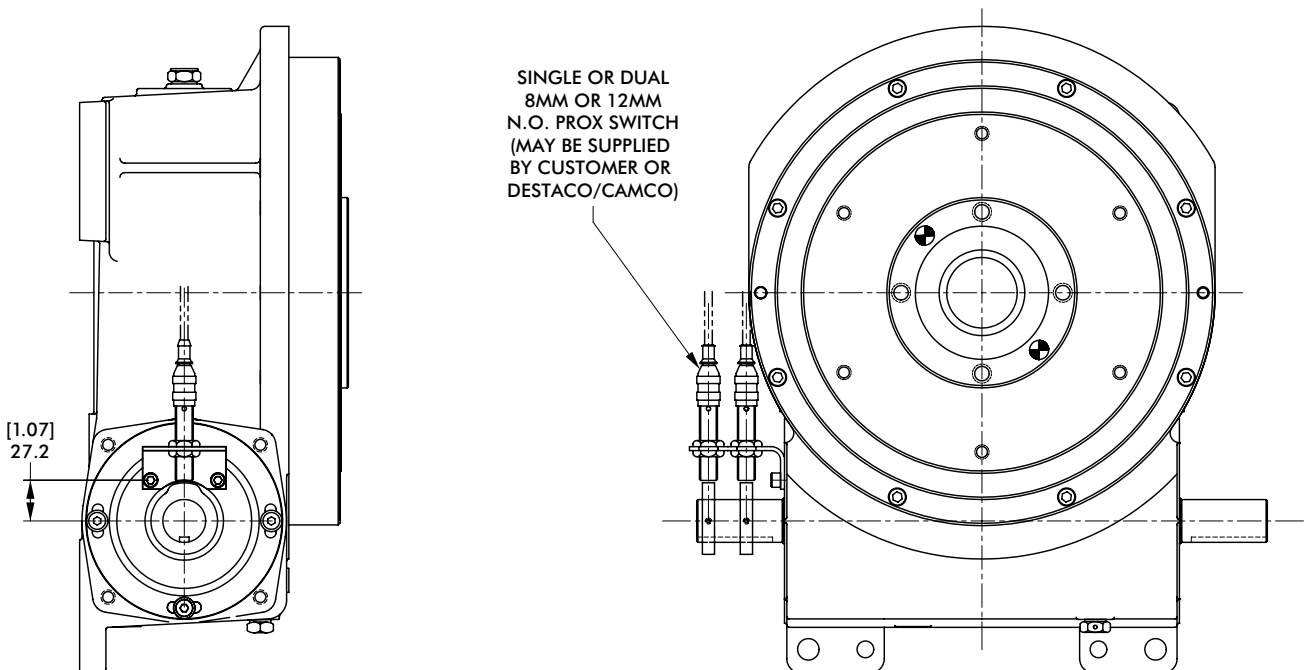
Proximity Switch



902RDM SERIES

Rotary Index Drive | Dimensions

7.8D Overload Clutch

THRU-HOLE CLUTCH

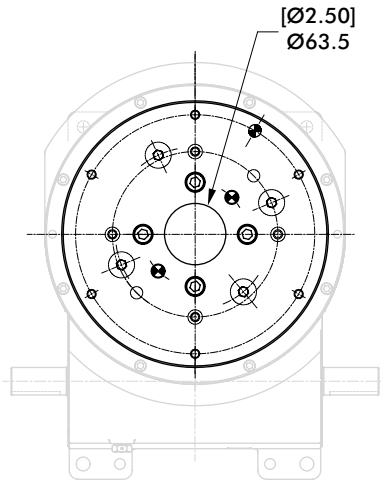

STANDARD CLUTCH

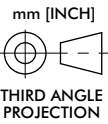
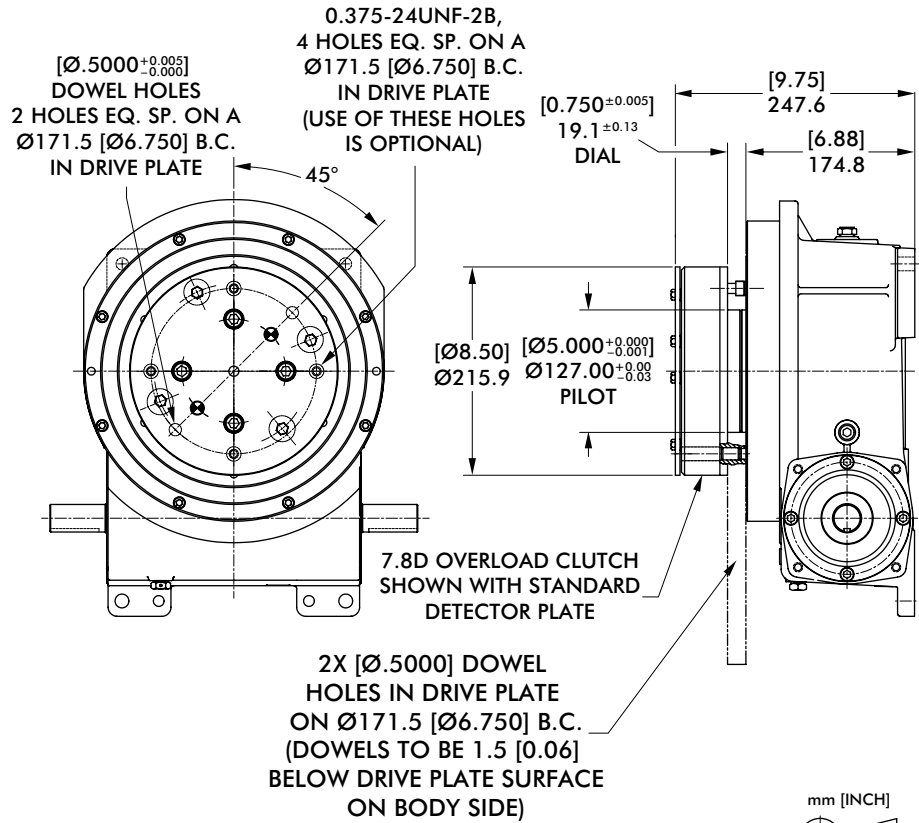

7.8D Overload Clutch with EZ Dial Mounting Adapter

THRU-HOLE EZ CLUTCH

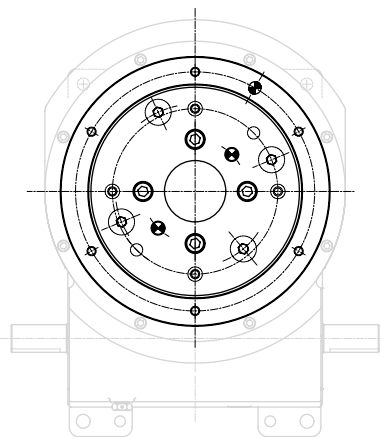

STANDARD EZ CLUTCH

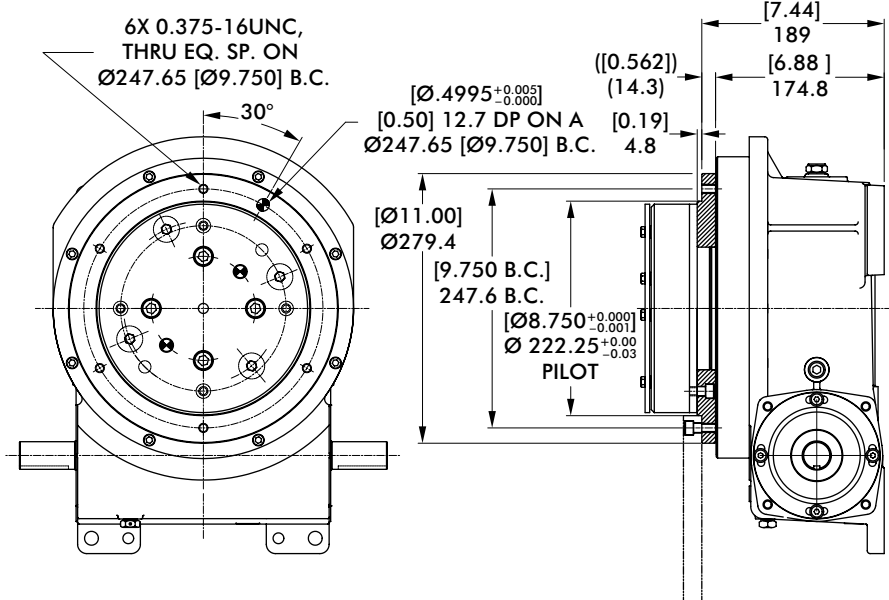

Model	Internal Inertia kg-m ² [lb-in ²]	Torque Setting N-m [in-lb]
7.8D	0,0778 [266]	158, 192, 294, 362, 475, 565, 813, 1130 [1400, 1700, 2600, 3200, 4200, 5000, 7200, 10000]

902RDM SERIES

Notes

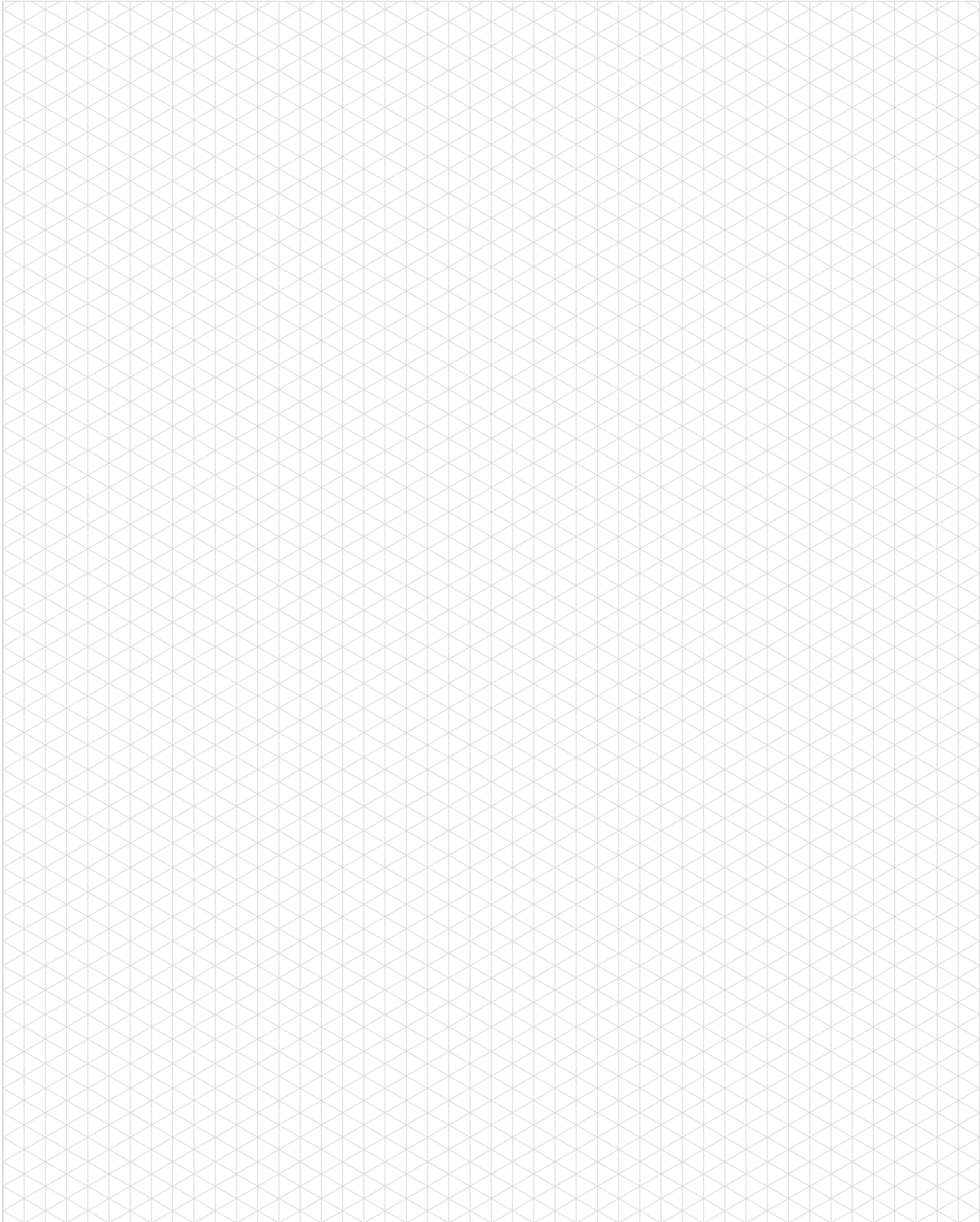

1100RDM SERIES

Rotary Index Drive | How To Order

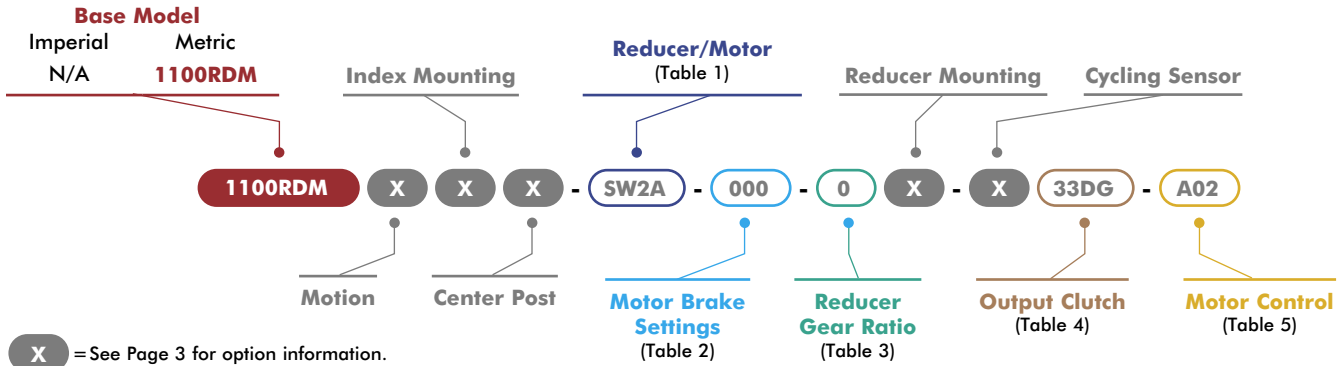

1 Reducer/Motor Options

Code	Description
0000	No Reducer or Motor*
7300C Motors	
CD1A	Indexer with 7300C Adapter*
CS1B	CONE DRIVE 7300C W/56C Reducer, SE Worm
CS1C	CONE DRIVE 7300C W/145TC Reducer, SE Worm
CS1D	CONE DRIVE 7300C Reducer w/ 1.0HP AC 56C Motor, SE Worm
CS1E	CONE DRIVE 7300C Reducer w/ 2.0HP AC 145TC Motor, SE Worm
CS1F	CONE DRIVE 7300C Reducer w/ 1.0HP 90V DC 56C Motor, SE Worm
CS1G	CONE DRIVE 7300C Reducer w/1.0HP 180V DC 56C Motor, SE Worm
CS1H	CONE DRIVE 7300C Reducer w/ 2.0HP 180V DC 143TC Motor, SE Worm
CD1B	CONE DRIVE 7300C w/ 56C Reducer, DE Worm
CD1C	CONE DRIVE 7300C W/145TC Reducer, DE Worm
CD1D	CONE DRIVE 7300C Reducer w/ 1.0HP AC 56C Motor, DE Worm
CD1E	CONE DRIVE 7300C Reducer w/ 2.0HP AC 145TC Motor, DE Worm
CD1F	CONE DRIVE 7300C Reducer w/ 1.0HP 90V DC 56C Motor, DE Worm
CD1G	CONE DRIVE 7300C Reducer w/ 1.0HP 180V DC 56C Motor, DE Worm
CD1H	CONE DRIVE 7300C Reducer w/ 2.0HP 180V DC 143TC Motor, DE Worm
SEW KH47 Motors	
SW2A	Indexer with KH47 Adapter*
SW2B	SEW KH47DRN80M4/.75Kw Motor/Brake Motor (60Hz, 230/460V)
SW2C	SEW KH47DRN80M4/.75Kw Motor/Brake Motor (50Hz, 200/400V)
SW2D	SEW KH47DRN80M4/.75Kw Motor/Brake Motor (60Hz, 575V)
SW2E	SEW KH47DRN90L4/1.5Kw Motor/Brake Motor (60Hz, 230/460V)
SW2F	SEW KH47DRN90L4/1.5Kw Motor/Brake Motor (50Hz, 200/400V)
SEW KH57 Motors	
SW3A	Indexer with KH57 Adapter*
SW3B	SEW KH57DRN80M4/.75Kw Motor/Brake Motor (60Hz, 230/460V)
SW3C	SEW KH57DRN80M4/.75Kw Motor/Brake Motor (50Hz, 200/400V)
SW3D	SEW KH57DRN80M4/.75Kw Motor/Brake Motor (60Hz, 575V)
SW3E	SEW KH57DRN90L4/1.5Kw Motor/Brake Motor (60Hz, 230/460V)
SW3F	SEW KH57DRN90L4/1.5Kw Motor/Brake Motor (50Hz, 200/400V)
SW3G	SEW KH57DRN90L4/1.5Kw Motor/Brake Motor (60Hz, 575V)
STM RMI-85 Motors	
RM6A	Indexer with RMI-85 Adapter*
RM6B	STM RMI-85/LFB/IEC90-B14 Reducer only
RM6C	STM RMI-85/LFB/IEC100-B14 Reducer only
RM6D	STM RMI-85/LFB/1.1kW Reducer and Motor
RM6E	STM RMI-85/LFB/2.2kW Reducer and Motor

*All Reducer/Motor adapters require Gear Ratio option to be 0.

2 Motor Brake* 3 Reducer Gear Ratios*

Code	Description
000	No Brake
S1A	1.69 Nm (BE05)
S1B	2.49 Nm (BE05)
S1C	3.50 Nm (BE05)
S2A	4.97 Nm (BE1)
S2B	7.01 Nm (BE1)
S2C	9.94 Nm (BE1)
S3A	9.94 Nm (BE2)
S3B	14.01 Nm (BE2)
S3C	20.00 Nm (BE2)
S4A	20.00 Nm (BE5)
S4B	28.02 Nm (BE5)
S4C	40.00 Nm (BE5)
S4D	55.03 Nm (BE5)

Code	Description			
	7300C	SEW KH47	SEW KH57	STM RMI-85
0	N/A	N/A	N/A	N/A
A	10:1	10.56:1	9.59:1	10:1
B	15:1	15.86:1	15.22:1	15:1
C	20:1	19.58:1	19.34:1	20:1
D	25:1	29.32:1	30.28:1	28:1
E	30:1	39.61:1	38.49:1	40:1
F	40:1	48.95:1	48.89:1	49:1
G	50:1	63.30:1	60.81:1	56:1
H	60:1	69.84:1	69.12:1	70:1

*All Reducer/Motor adapters require Gear Ratio option to be 0.
Select Gear ratio column based on the reducer type selected.

*SEW Motor brake setting options only. All other motors use option code 000.

4 Output Clutch & Settings

Code	Description
0000	No Output Overload Clutch
33DA	33D/960 Nm, Standard Clutch*
33DB	33D/1470 Nm, Standard Clutch*
33DC	33D/1865 Nm, Standard Clutch*
33DD	33D/2260 Nm, Standard Clutch*
33DE	33D/2655 Nm, Standard Clutch*
33DF	33D/2880 Nm, Standard Clutch*
33DG	33D/3500 Nm, Standard Clutch*
33DH	33D/960 Nm, Thru-Hole Clutch
33DJ	33D/1470 Nm, Thru-Hole Clutch
33DK	33D/1865 Nm, Thru-Hole Clutch
33DL	33D/2260 Nm, Thru-Hole Clutch
33DM	33D/2655 Nm, Thru-Hole Clutch
33DN	33D/2880 Nm, Thru-Hole Clutch
33DP	33D/3500 Nm, Thru-Hole Clutch
33EA	33D/960 Nm, Standard Clutch, EZ*
33EB	33D/1470 Nm, Standard Clutch, EZ*
33EC	33D/1865 Nm, Standard Clutch, EZ*
33ED	33D/2260 Nm, Standard Clutch, EZ*
33EE	33D/2655 Nm, Standard Clutch, EZ*
33EF	33D/2880 Nm, Standard Clutch, EZ*
33EG	33D/3500 Nm, Standard Clutch, EZ*
33EH	33D/960 Nm, Thru-Hole Clutch, EZ
33EJ	33D/1470 Nm, Thru-Hole Clutch, EZ
33EK	33D/1865 Nm, Thru-Hole Clutch, EZ
33EL	33D/2260 Nm, Thru-Hole Clutch, EZ
33EM	33D/2655 Nm, Thru-Hole Clutch, EZ
33EN	33D/2880 Nm, Thru-Hole Clutch, EZ
33EP	33D/3500 Nm, Thru-Hole Clutch, EZ

* Cannot be used with center post options P and B.

5 Motor Control

Code	Description	
000	NO MOTOR CONTROL	
A01	120V 1Ph	
A02	(AC) PowerFlex 523 1HP	
A03	480V 3Ph	
A04	120V 1Ph	
A05	(AC) PowerFlex 525 1HP	
A06	240V 1Ph	
A07	480V 3Ph	
A08	(AC) PowerFlex 523 2HP	
A09	240V 3Ph	
A10	(AC) PowerFlex 525 2HP	
A11	480V 3Ph	
A12	(AC) PowerFlex 523 3HP	
A13	240V 1Ph	
A14	(AC) PowerFlex 525 3HP	
A15	480V 3Ph	
A16	(AC) PowerFlex 523 5HP	
A17	600V 3Ph	
A18	(AC) PowerFlex 525 5HP	
D01	600V 3Ph	
D02	(DC) Varipak 1HP 90VDC	Uni-Directional
D03	(DC) Varipak 2HP 180VDC	Bi-Directional
D04	(DC) Varipak 2HP 180VDC	Uni-Directional
D05	(DC) Cycletrol 3HP 180VDC	Bi-Directional

Maximum Inertia x 1000 kg-cm ² [lb-in ²] for standard package							
Stops	Motion Time [seconds]						
	0.458	0.611	0.764	0.917	1.222	1.528	1.833
2	3 [1]	15 [5]	32 [11]	64 [22]	176 [60]	342 [117]	518 [177]
3	18 [6]	38 [13]	79 [27]	152 [52]	401 [137]	775 [265]	1171 [400]
4	38 [13]	79 [27]	161 [55]	304 [104]	790 [270]	1525 [521]	2297 [785]
6	88 [30]	179 [61]	351 [120]	664 [227]	1703 [582]	3283 [1122]	4940 [1688]
8	161 [55]	325 [111]	632 [216]	1185 [405]	3035 [1037]	5838 [1995]	7916 [2705]
12	369 [126]	735 [251]	1428 [488]	2672 [913]	6833 [2335]	12563 [4293]	16932 [5786]
16	658 [225]	1314 [449]	2543 [869]	4138 [1414]	7781 [2659]	11884 [4061]	16019 [5474]
Reducer Ratio							
	15.86	19.58	24.06	29.32	39.61	48.95	56.83

Other Motions (stops and index periods) available. Contact your DESTACO sales representative for more information.

Features

- KH47 Reducer and AC Motor with Optional Brake
- Double Extended Camshaft (Input Shaft)
- Center Thru Hole (Ø130 mm [Ø5.1 in.])
- AC drive package with Inverter Duty Motor and Inverter Drive (up to 60 cpm)
- Cycle Cam and Limit Switch Mounted to Camshaft
- Right Hand Cam

Output Load Capacity (loads carried during index):

Radial	13789 N [3100 lbs]
Thrust/Axial	35586 N [8000 lbs]
Moment	3240 N-m [28674 in-lb]

Typical Application Dial Diameter:

508 mm [20 in] to 1524 mm [60 in]

Accuracy

±22 arcsec / ±0,08 mm [±.003in]
at 76 mm [30in] Radius

Repeatability

±5 arcsec / ±0,020 mm [±.0008in]
at 762 mm [30in] Radius

Optional Accessories

- 7300C Reducer (Ratios from 15:1 to 60:1)
- 1.5 HP DC motor
- Varipak DC Motor Control (up to 30 cpm)
- Output Mechanical Overload Clutch
– See Page 27
- EZ Mount Dial Adapter
- 7350C Heavy Duty Reducer (Ratios from 10:1 to 60:1)
- Stationary Center Post
- Dual Cam and Limit Switch
- Left Hand Cam
- Relief in Dwell for shot-pin applications



1100RDM SERIES

Rotary Index Drive | Dimensions

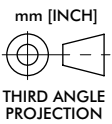
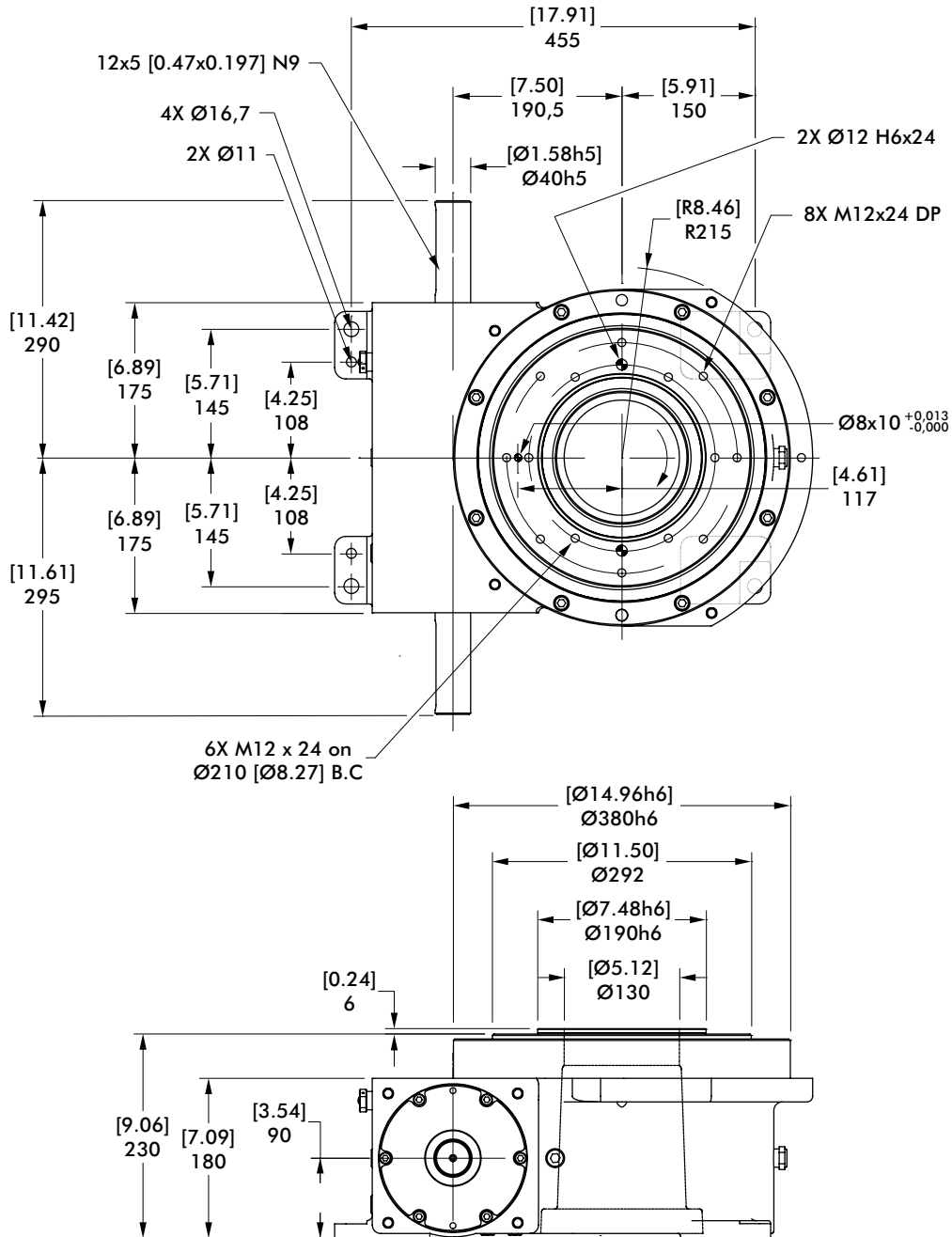

1100RDM SERIES

Rotary Index Drive | Product Overview | Technical Specifications

Center Post

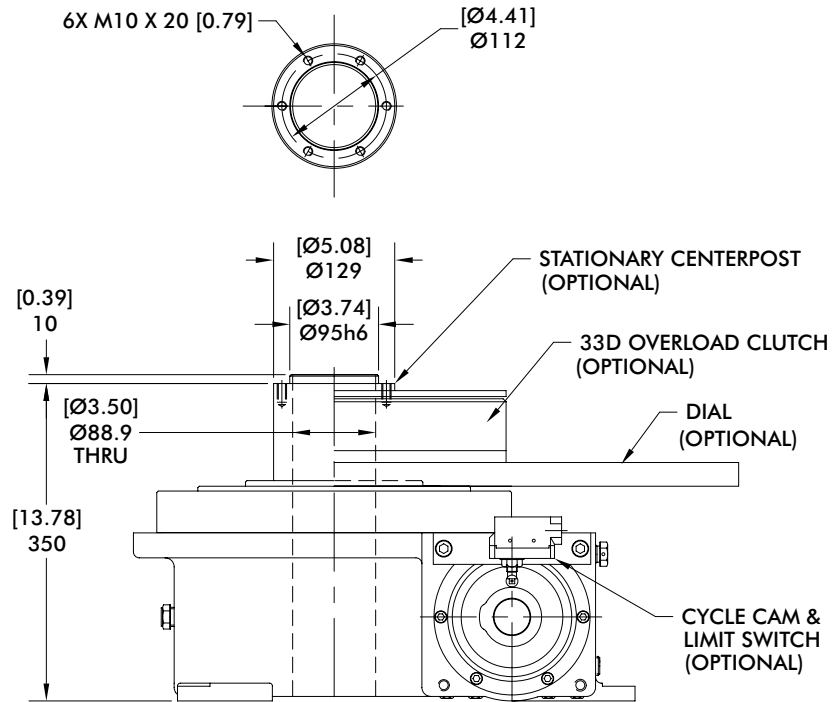

mm [INCH]

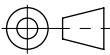

THIRD ANGLE PROJECTION

Proximity Switch

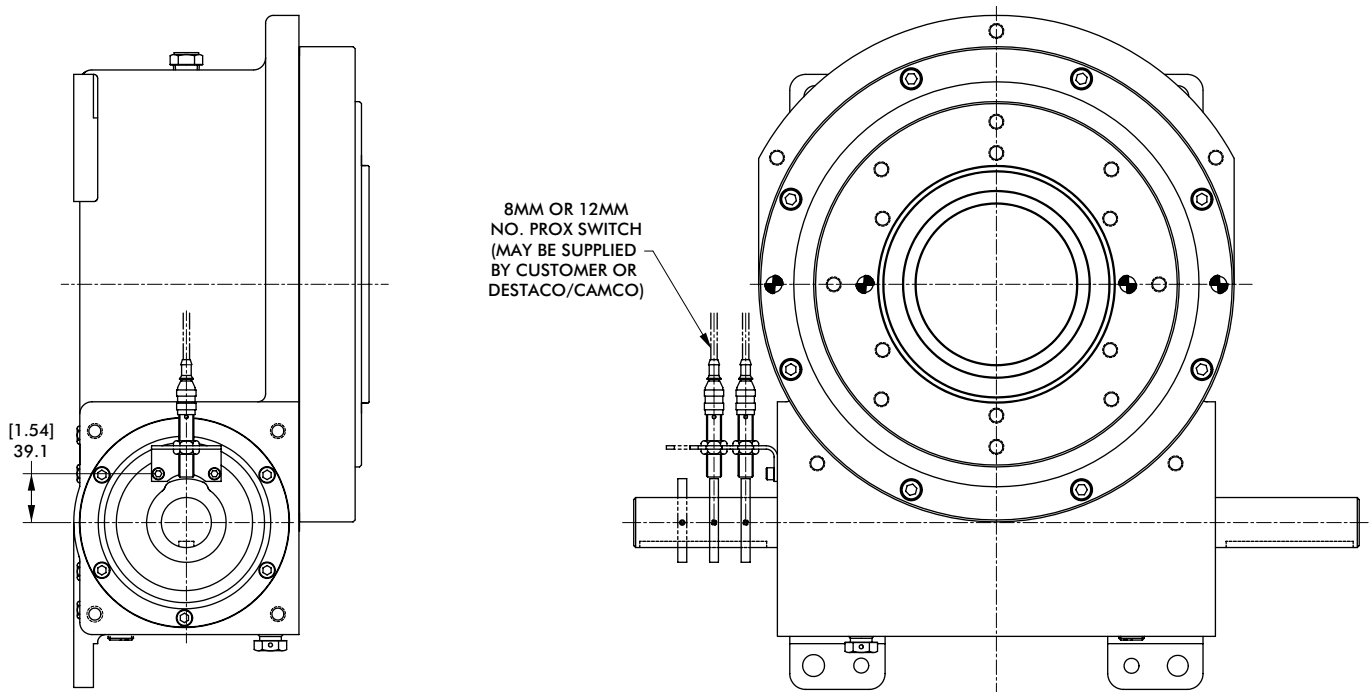

1100RDM SERIES

Rotary Index Drive | Dimensions

33D Overload Clutch

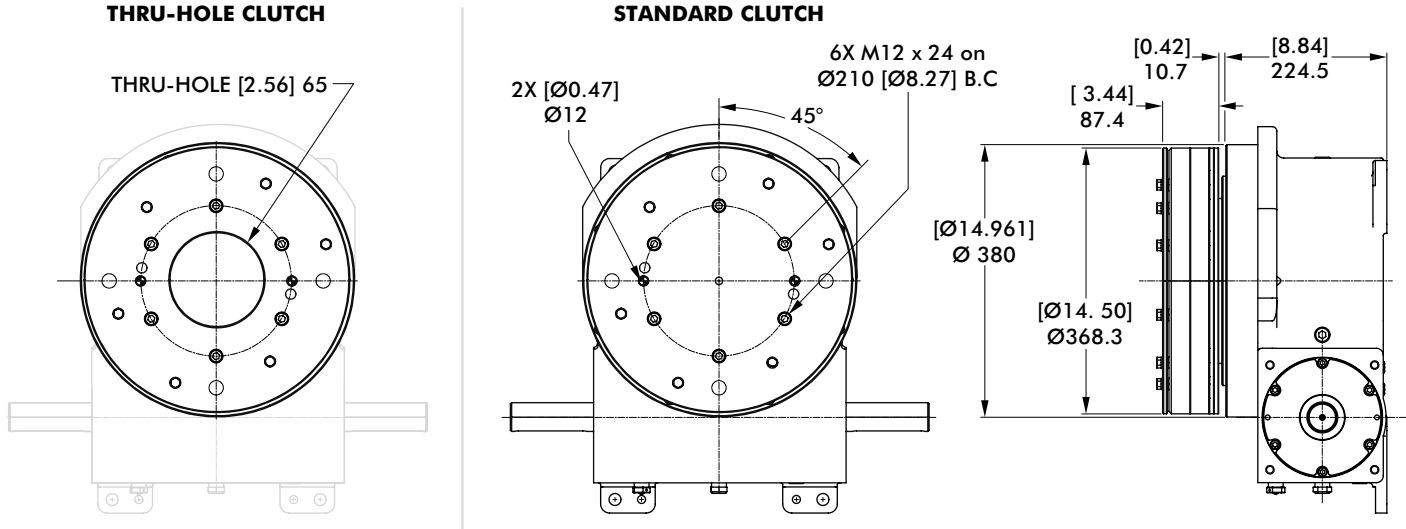

mm [INCH]



33D Overload Clutch with EZ Dial Mounting Adapter

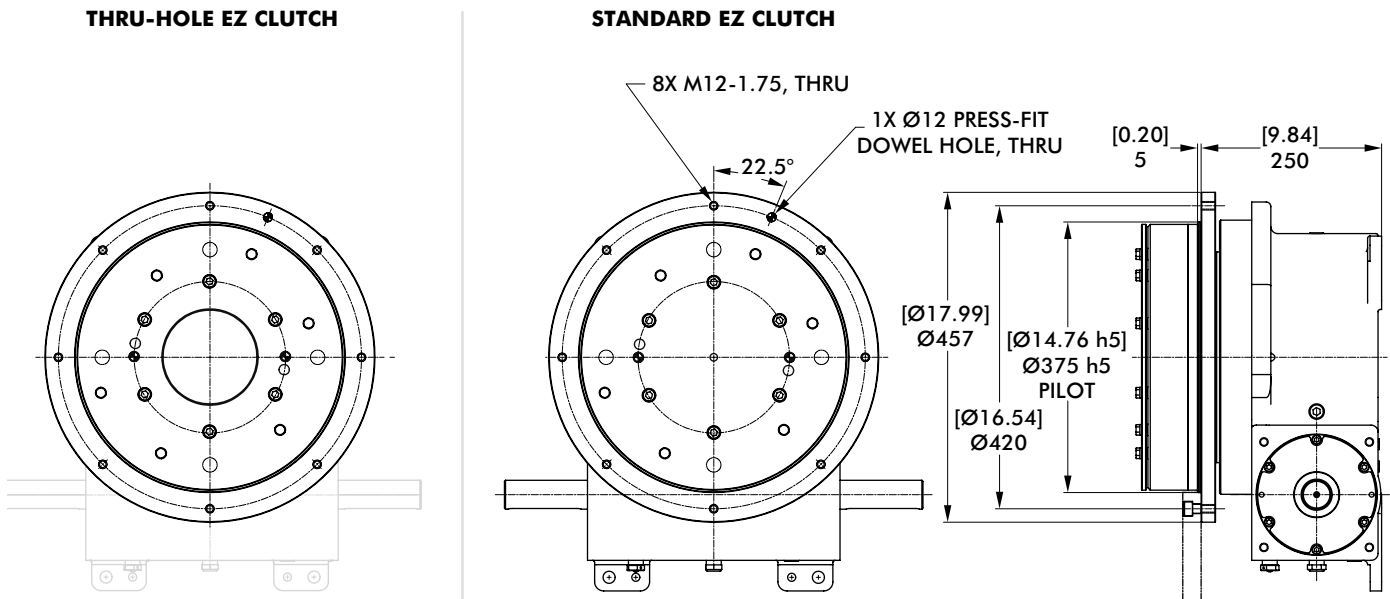

Model	Internal Inertia kg-m ² [lb-in ²]	Torque Setting N-m [in-lb]
33D	0,852 [2910]	960, 1469, 2260, 2881 [8500, 13000, 20000, 25500]

1100RDM SERIES

Notes

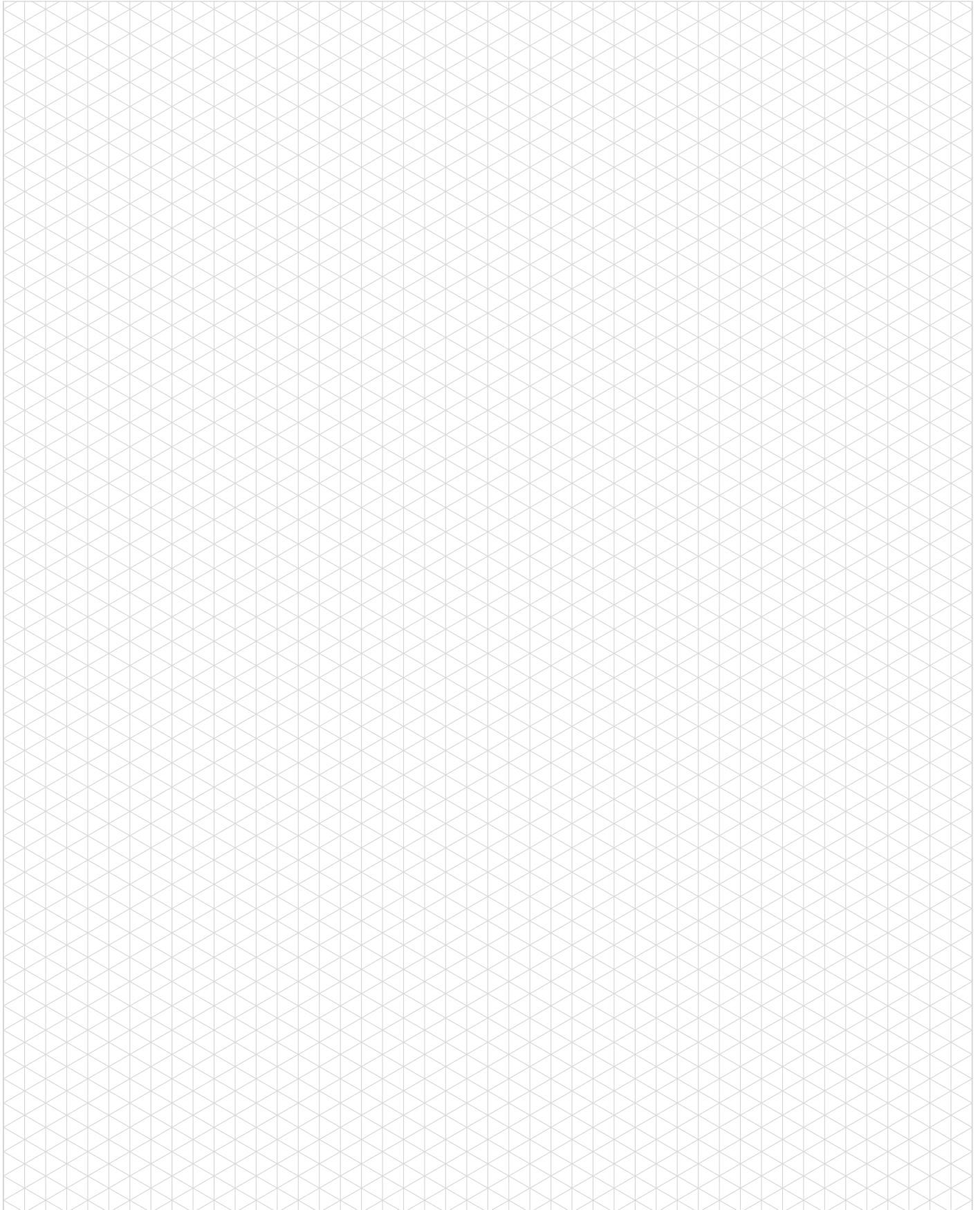

1305RDM SERIES

Rotary Index Drive | How To Order

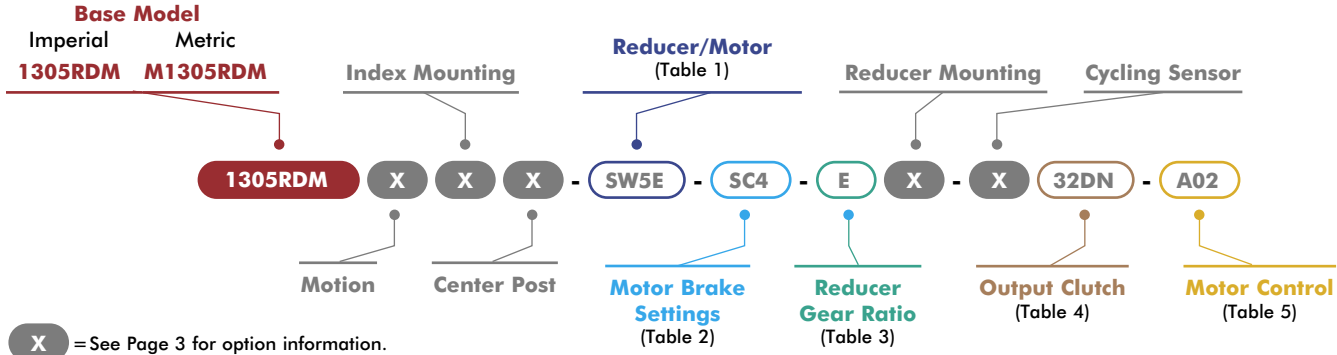

1 Reducer/Motor Options*

Code	Description
0000	No Reducer or Motor*
7350C Motors	
CD2A	Indexer with 7350C Adapter*
CS2B	CONE DRIVE 7350C W/56C Reducer, SE Worm
CS2C	CONE DRIVE 7350C W/145TC Reducer, SE Worm
CS2D	CONE DRIVE 7350C Reducer w/ 1.0HP AC 56C Motor, SE Worm
CS2E	CONE DRIVE 7350C Reducer w/ 2.0HP AC 145TC Motor, SE Worm
CS2F	CONE DRIVE 7350C Reducer w/ 1.0HP 90V DC 56C Motor, SE Worm
CS2G	CONE DRIVE 7350C Reducer w/1.0HP 180V DC 56C Motor, SE Worm
CS2H	CONE DRIVE 7350C Reducer w/2.0HP 180V DC 143TC Motor, SE Worm
CD2B	CONE DRIVE 7350C w/ 56C Reducer, DE Worm
CD2C	CONE DRIVE 7350C W/145TC Reducer, DE Worm
CD2D	CONE DRIVE 7350C Reducer w/ 1.0HP AC 56C Motor, DE Worm
CD2E	CONE DRIVE 7350C Reducer w/ 2.0HP AC 145TC Motor, DE Worm
CD2F	CONE DRIVE 7350C Reducer w/ 1.0HP 90V DC 56C Motor, DE Worm
CD2G	CONE DRIVE 7350C Reducer w/ 1.0HP 180V DC 56C Motor, DE Worm
CD2H	CONE DRIVE 7350C Reducer w/ 2.0HP 180V DC 143TC Motor, DE Worm
SEW KH67 Motors	
SW4A	Indexer with KH67 Adapter*
SW4B	SEW KH67DRN80M4 Reducer with 0.75Kw Motor (60Hz, 230/460V)
SW4C	SEW KH67DRN80M4 Reducer with 0.75Kw Motor (50Hz, 400V)
SW4D	SEW KH67DRN80M4 Reducer with 0.75Kw Motor (60Hz, 575V)
SW4E	SEW KH67DRN90L4 Reducer with 1.5Kw Motor (60Hz, 230/460V)
SW4F	SEW KH67DRN90L4 Reducer with 1.5Kw Motor (50Hz, 400V)
SW4G	SEW KH67DRN90L4 Reducer with 1.5Kw Motor (60Hz, 575V)
SEW KH77 Motors	
SW5A	Indexer with KH77 Adapter*
SW5B	SEW KH77DRN80M4 Reducer with 0.75Kw Motor (60Hz, 230/460V)
SW5C	SEW KH77DRN80M4 Reducer with 0.75Kw Motor (50Hz, 400V)
SW5D	SEW KH77DRN80M4 Reducer with 0.75Kw Motor (60Hz, 575V)
SW5E	SEW KH77DRN90L4 Reducer with 1.5Kw Motor (60Hz, 230/460V)
SW5F	SEW KH77DRN90L4 Reducer with 1.5Kw Motor (50Hz, 400V)
SW5G	SEW KH77DRN90L4 Reducer with 1.5Kw Motor (60Hz, 575V)
STM RMI-110 Motors	
RM7A	Indexer with RMI-110 Adapter*
RM7B	STM RMI-110/LFB/IEC90-B14 Reducer only
RM7C	STM RMI-110/LFB/IEC100-B14 Reducer only
RM7D	STM RMI-110/LFB/1.1kW Reducer and Motor
RM7E	STM RMI-110/LFB/2.2kW Reducer and Motor

*All Reducer/Motor adapters require Gear Ratio option to be 0.

2 Motor Brake*

Code	Description
000	(NO BRAKE/NO SEW)
S1A	1.69 Nm (BE05)
S1B	2.49 Nm (BE05)
S1C	3.50 Nm (BE05)
S2A	4.97 Nm (BE1)
S2B	7.01 Nm (BE1)
S2C	9.94 Nm (BE1)
S3A	9.94 Nm (BE2)
S3B	14.01 Nm (BE2)
S3C	20.00 Nm (BE2)
S4A	20.00 Nm (BE5)
S4B	28.02 Nm (BE5)
S4C	40.00 Nm (BE5)
S4D	55.03 Nm (BE5)

*SEW Motor brake setting options only. All other motors use option code 000.

3 Reducer Gear Ratios*

Code	Description			
	7350C	SEW KH67	SEW KH77	STM RMI-110
0	N/A	N/A	N/A	N/A
A	10:1	9.66:1	9.56:1	10:1
B	15:1	15.19:1	15.84:1	15:1
C	20:1	19.30:1	20.25:1	20:1
D	28:1	30.22:1	29.27:1	25:1
E	40:1	38.39:1	40.04:1	30:1
F	49:1	48.77:1	51.18:1	40:1
G	56:1	60.66:1	58.34:1	50:1
H	70:1	68.95:1	73.99:1	60:1

*All Reducer/Motor adapters require Gear Ratio option to be 0.
Select Gear ratio column based on the reducer type selected.

4 Output Clutch & Settings

1305RDM Imperial Clutch Models		M1305RDM Metric Clutch Models	
Code	Description	Code	Description
0000	No Output Overload Clutch	0000	No Output Overload Clutch
32DA	32D/8500 In-Lb, Standard*	M32DA	M32D/960 Nm, Standard*
32DB	32D/13000 In-Lb, Standard*	M32DB	M32D/1470 Nm, Standard*
32DC	32D/20000 In-Lb, Standard*	M32DC	M32D/2260 Nm, Standard*
32DD	32D/31000 In-Lb, Standard*	M32DD	M32D/3500 Nm, Standard*
32DE	32D/16500 In-Lb, Standard*	M32DE	M32D/1865 Nm, Standard*
32DF	32D/25500 In-Lb, Standard*	M32DF	M32D/2880 Nm, Standard*
32DG	32D/23500 In-Lb, Standard*	M32DG	M32D/2655 Nm, Standard*
32DH	32D/8500 In-Lb, Thru-Hole	M32DH	M32D/960 Nm, Thru-Hole
32DJ	32D/13000 In-Lb, Thru-Hole	M32DJ	M32D/1470 Nm, Thru-Hole
32DK	32D/20000 In-Lb, Thru-Hole	M32DK	M32D/2260 Nm, Thru-Hole
32DL	32D/31000 In-Lb, Thru-Hole	M32DL	M32D/3500 Nm, Thru-Hole
32DM	32D/16500 In-Lb, Thru-Hole	M32DM	M32D/1865 Nm, Thru-Hole
32DN	32D/25500 In-Lb, Thru-Hole	M32DN	M32D/2880 Nm, Thru-Hole
32DP	32D/23500 In-Lb, Thru-Hole	M32DP	M32D/2655 Nm, Thru-Hole
32EA	32D/8500 In-Lb, Standard, EZ*	M32EA	M32D/960 Nm, Standard, EZ*
32EB	32D/13000 In-Lb, Standard, EZ*	M32EB	M32D/1470 Nm, Standard, EZ*
32EC	32D/20000 In-Lb, Standard, EZ*	M32EC	M32D/2260 Nm, Standard, EZ*
32ED	32D/31000 In-Lb, Standard, EZ*	M32ED	M32D/3500 Nm, Standard, EZ*
32EE	32D/16500 In-Lb, Standard, EZ*	M32EE	M32D/1865 Nm, Standard, EZ*
32EF	32D/25500 In-Lb, Standard, EZ*	M32EF	M32D/2880 Nm, Standard, EZ*
32EG	32D/23500 In-Lb, Standard, EZ*	M32EG	M32D/2655 Nm, Standard, EZ*
32EH	32D/8500 In-Lb, Thru-Hole, EZ	M32EH	M32D/960 Nm, Thru-Hole, EZ
32EJ	32D/13000 In-Lb, Thru-Hole, EZ	M32EJ	M32D/1470 Nm, Thru-Hole, EZ
32EK	32D/20000 In-Lb, Thru-Hole, EZ	M32EK	M32D/2260 Nm, Thru-Hole, EZ
32EL	32D/31000 In-Lb, Thru-Hole, EZ	M32EL	M32D/3500 Nm, Thru-Hole, EZ
32EM	32D/16500 In-Lb, Thru-Hole, EZ	M32EM	M32D/1865 Nm, Thru-Hole, EZ
32EN	32D/25500 In-Lb, Thru-Hole, EZ	M32EN	M32D/2880 Nm, Thru-Hole, EZ
32EP	32D/23500 In-Lb, Thru-Hole, EZ	M32EP	M32D/2655 Nm, Thru-Hole, EZ

* Cannot be used with center post options P and B.

5 Motor Control

Code	Description
000	NO MOTOR CONTROL
A01	120V 1Ph
A02	(AC) PowerFlex 523 1HP
A03	480V 3Ph
A04	120V 1Ph
A05	(AC) PowerFlex 525 1HP
A06	480V 3Ph
A07	240V 1Ph
A08	(AC) PowerFlex 523 2HP
A09	480V 3Ph
A10	(AC) PowerFlex 525 2HP
A11	240V 3Ph
A12	(AC) PowerFlex 523 3HP
A13	480V 3Ph
A14	(AC) PowerFlex 525 3HP
A15	480V 3Ph
A16	(AC) PowerFlex 523 5HP
A17	600V 3Ph
A18	(AC) PowerFlex 525 5HP
D01	(DC) Varipak 1HP 90VDC
D02	Uni-Directional
D03	Bi-Directional
D04	(DC) Varipak 2HP 180VDC
D05	Uni-Directional
	Bi-Directional

Maximum Inertia x 1000 kg-cm ² [lb-in ²] for standard package							
Stops	Motion Time [seconds]						
	0.458	0.611	0.764	0.917	1.222	1.528	1.833
2	0 [0]	12 [4]	38 [13]	76 [26]	140 [48]	214 [73]	298 [102]
3	6 [2]	32 [11]	76 [26]	146 [50]	258 [88]	389 [133]	538 [184]
4	29 [10]	94 [32]	208 [71]	380 [130]	664 [227]	995 [340]	1367 [467]
6	73 [25]	211 [72]	451 [154]	822 [281]	1419 [485]	2119 [724]	2909 [994]
8	138 [47]	383 [131]	811 [277]	1469 [502]	2528 [864]	3775 [1290]	5180 [1770]
12	325 [111]	878 [300]	1841 [629]	3319 [1134]	5706 [1950]	8510 [2908]	11670 [3988]
16	585 [200]	1571 [537]	3280 [1121]	5908 [2019]	10155 [3470]	15138 [5173]	20754 [7092]
Reducer Ratio							
	15	20	25	30	40	50	60

Other Motions (stops and index periods) available. Contact your DESTACO sales representative for more information.

Features

- 7300C Reducer (Ratios from 15:1 to 60:1)
- Double Extended Camshaft (Input Shaft)
- Center Thru Hole (Ø127 mm [Ø5.00 in.])
- 2 HP AC Drive Package with Inverter Duty Motor and Inverter Drive (up to 60 cpm)
- Cycle Cam and Limit Switch Mounted to Camshaft
- Right Hand Cam

Output Load Capacity (loads carried during index):

Radial	20684 N [4650 lbs]
Thrust/Axial	51822 N [11650 lbs]
Moment	4579 N-m [40528 in-lb]

Typical Application Dial Diameter:

508 mm [20 in] to 1829 mm [72 in]

Accuracy

±38 arcsec / ±0,18 mm [±.007in]
at 914,4 mm [36in] Radius

Repeatability

±10 arcsec / ±0,05 mm [±.002in]
at 914,4 mm [36in] Radius

Optional Accessories

- 2 hp DC Motor
- Varipak DC Motor Control (up to 30 cpm)
- 7350C Heavy Duty Reducer (Ratios from 10:1 to 60:1)
- Output Mechanical Overload Clutch
– See Page 33
- EZ Mount Dial Adapter
- Stationary Center Post
- Dual Cam and Limit Switch
- Base Riser Blocks
- Electric Clutch-Brake
- Left Hand Cam
- Relief in Dwell for shot-pin applications

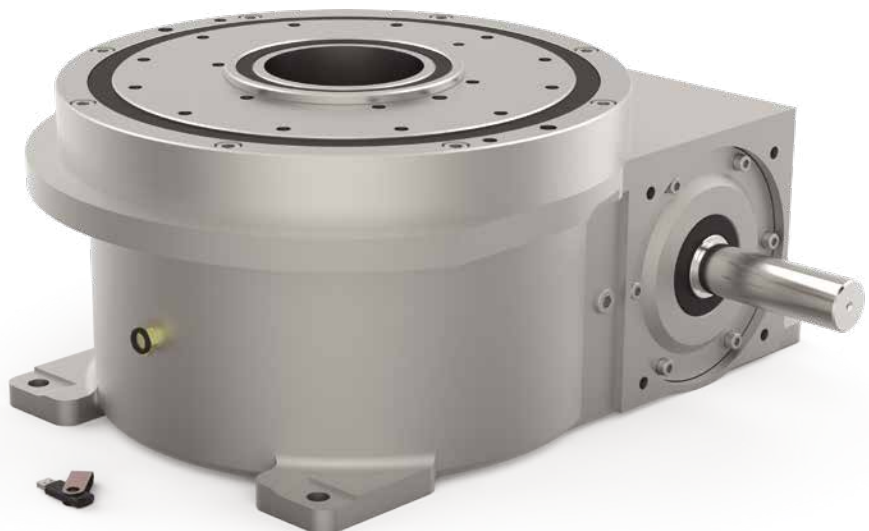

1305RDM SERIES

Rotary Index Drive | Product Overview | Technical Specifications

Center Post

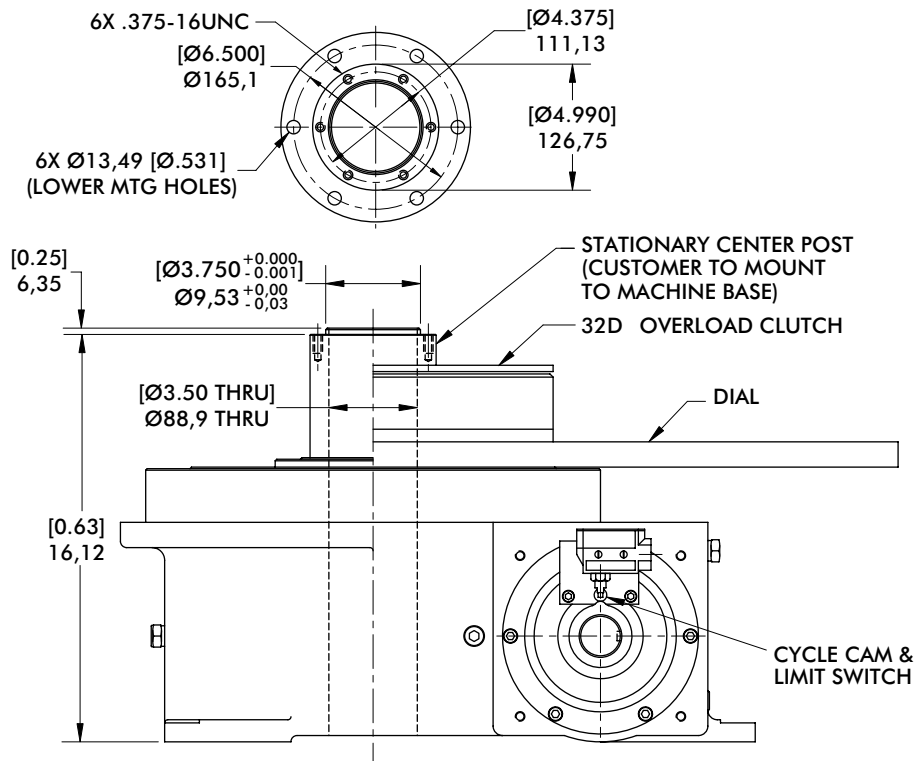

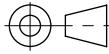
mm [INCH]

 THIRD ANGLE
 PROJECTION

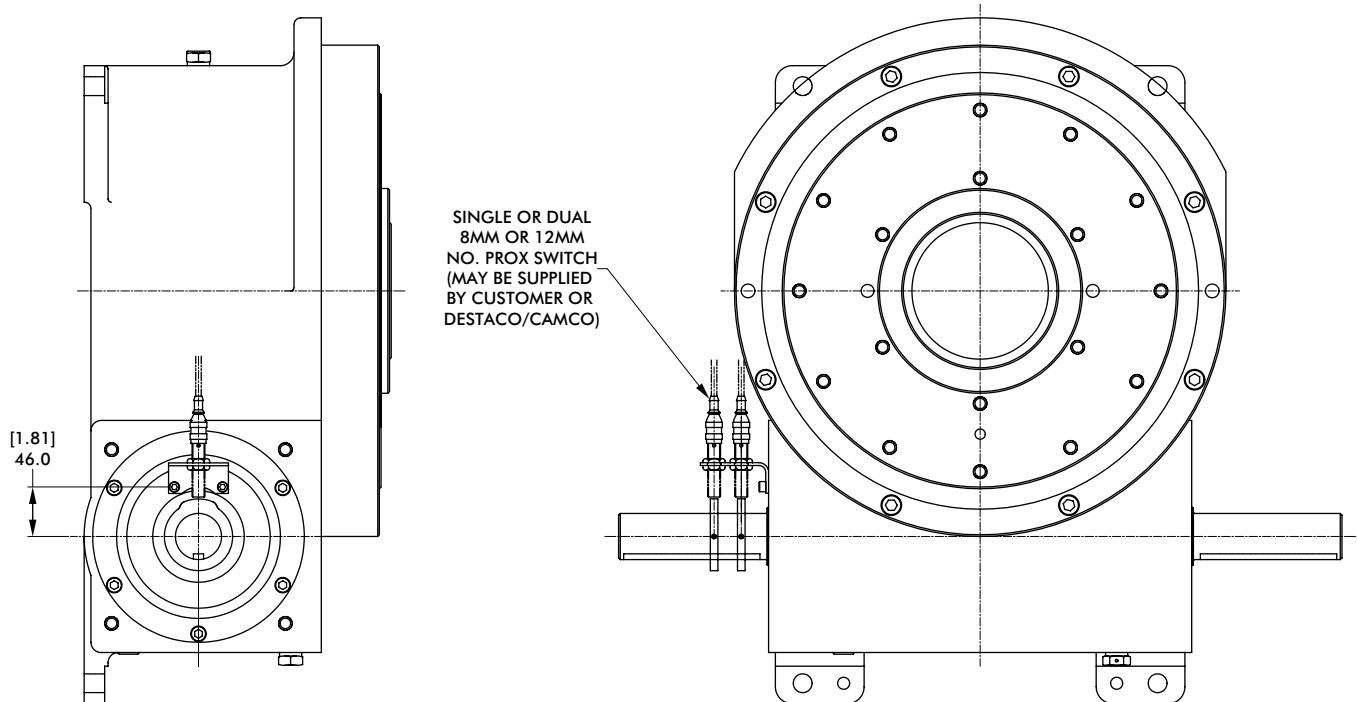
Proximity Switch



1305RDM SERIES

Rotary Index Drive | Dimensions

32D Overload Clutch

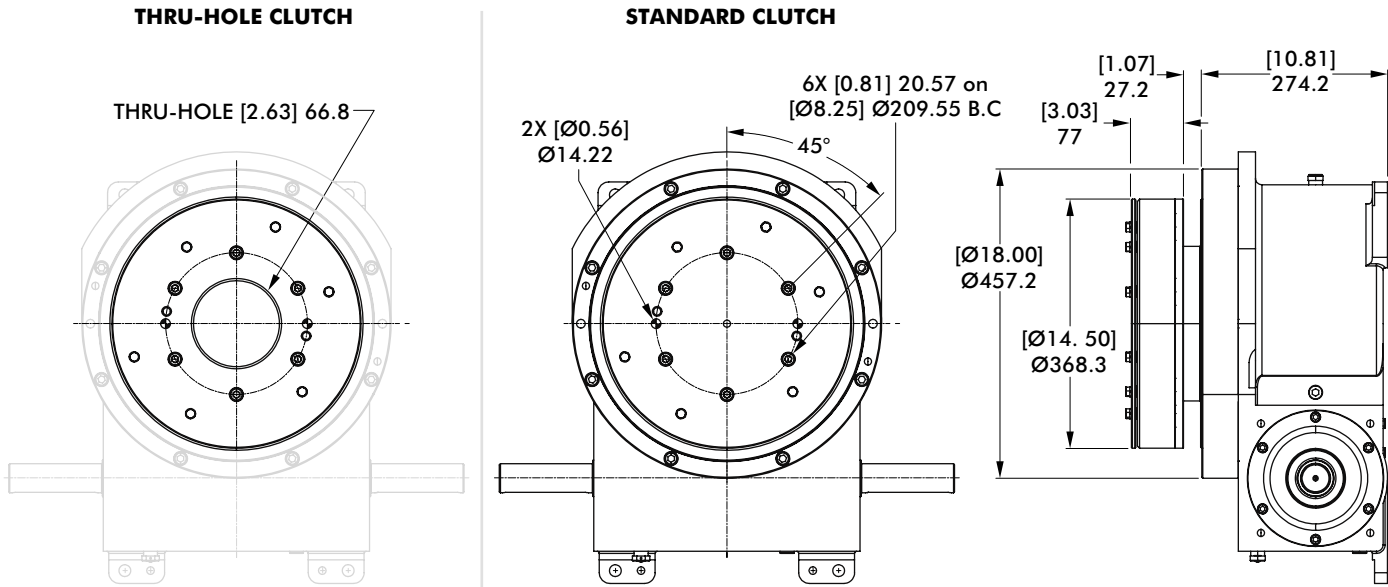

32D Overload Clutch with EZ Dial Mounting Adapter

mm [INCH]

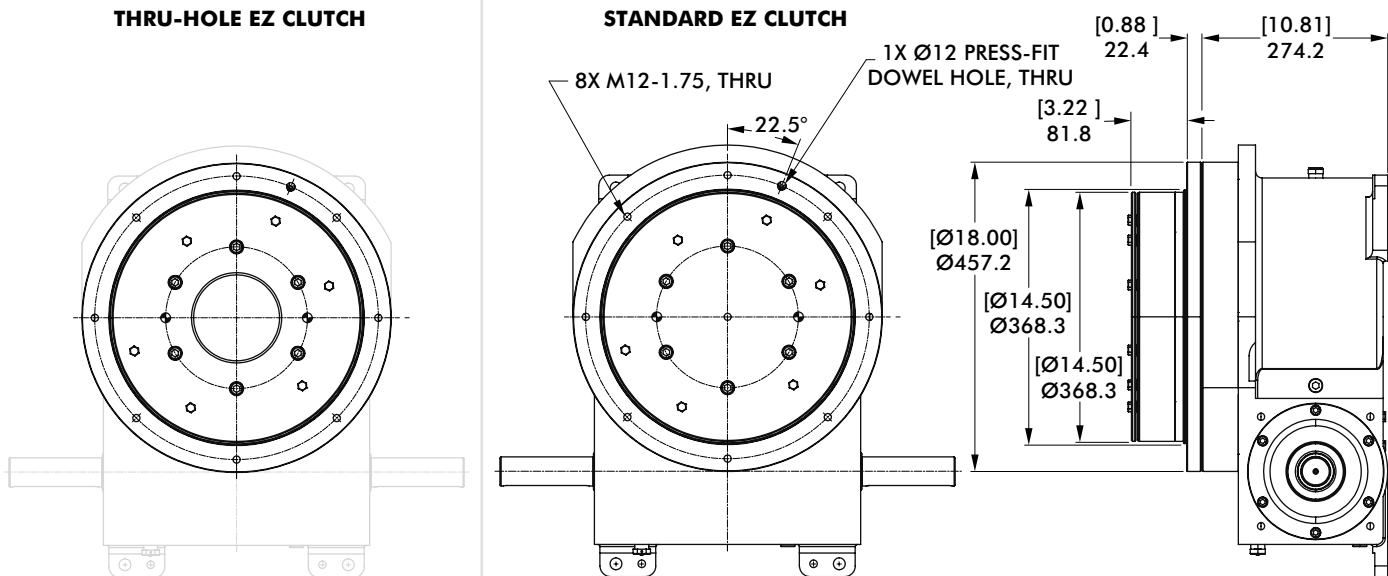

Model	Internal Inertia kg-m ² [lb-in ²]	Torque Setting N-m [in-lb]
32D	0,852 [2910]	960, 1469, 2260, 3503 [8500, 13000, 20000, 31000]

1305RDM SERIES

Notes

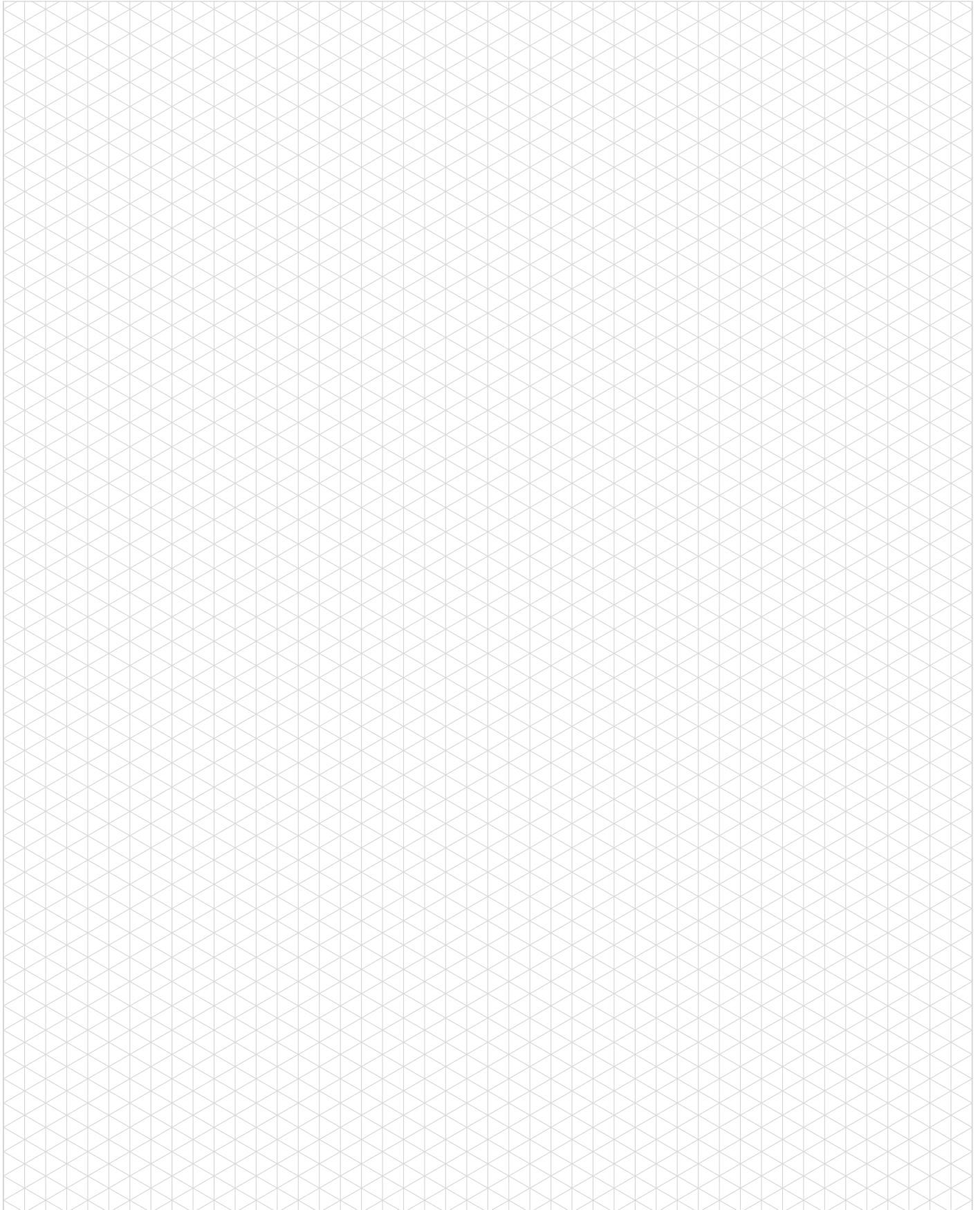

1800RDM SERIES

Rotary Index Drive | How To Order

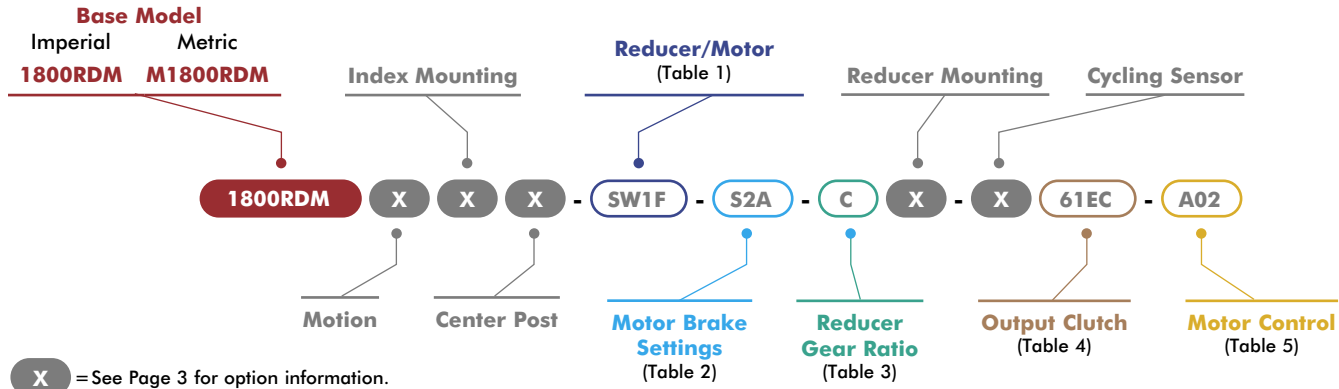

1 Reducer/Motor Options

Code	Description
0000	No Reducer or Motor*
7400C Motors	
CD3A	Indexer with 7400C Adapter*
CS3B	CONE DRIVE 7400C W/145TC Reducer, SE Worm
CS3C	CONE DRIVE 7400C W/182TC Reducer, SE Worm
CS3D	CONE DRIVE 7400C Reducer w/ 2.0HP AC 145TC Motor, SE Worm
CS3E	CONE DRIVE 7400C Reducer w/ 3.0HP AC 182TC Motor, SE Worm
CS2F	CONE DRIVE 7400C Reducer w/2.0HP 180V DC 143TC Motor, SE Worm
CS2G	CONE DRIVE 7400C Reducer w/3.0HP 180V DC 145TC Motor, SE Worm
CD3B	CONE DRIVE 7400C W/145TC Reducer, DE Worm
CD3C	CONE DRIVE 7400C W/182TC Reducer, DE Worm
CD3D	CONE DRIVE 7400C Reducer w/2.0HP AC 145TC Motor, DE Worm
CD3E	CONE DRIVE 7400C Reducer w/3.0HP AC 182TC Motor, DE Worm
CD2F	CONE DRIVE 7400C Reducer w/ 2.0HP 180V DC 143TC Motor, DE Worm
CD2G	CONE DRIVE 7400C Reducer w/ 3.0HP 180V DC 145TC Motor, DE Worm
SEW KH77 Motors	
SW5A	Indexer with KH77 Adapter*
SW5H	SEW KH77DRN100L4 Reducer with 2.2Kw Motor (60Hz, 230/460V)
SW5J	SEW KH77DRN100L4 Reducer with 2.2Kw Motor (50Hz, 400V)
SW5K	SEW KH77DRN100L4 Reducer with 2.2Kw Motor (60Hz, 575V)
SW5L	SEW KH77DRN100L4 Reducer with 3.7Kw Motor (60Hz, 230/460V)
SW5M	SEW KH77DRN100L4 Reducer with 3.7Kw Motor (50Hz, 400V)
SW5N	SEW KH77DRN100L4 Reducer with 3.7Kw Motor (60Hz, 575V)
SEW KH87 Motors	
SW6A	Indexer with KH87 Adapter*
SW6B	SEW KH87DRN100L4 Reducer with 2.2Kw Motor/Brake Motor (60Hz, 230/460V)
SW6C	SEW KH87DRN100L4 Reducer with 2.2Kw Motor/Brake Motor (50Hz, 400V)
SW6D	SEW KH87DRN100L4 Reducer with 2.2Kw Motor/Brake Motor (60Hz, 575V)
SW6E	SEW KH87DRN100L4 Reducer with 3.7Kw Motor/Brake Motor (60Hz, 230/460V)
SW6F	SEW KH87DRN100L4 Reducer with 3.7Kw Motor/Brake Motor (50Hz, 400V)
SW6G	SEW KH87DRN100L4 Reducer with 3.7Kw Motor/Brake Motor (60Hz, 575V)
STM RMI-150 Motors	
RM8A	Indexer with RMI-150 Adapter*
RM8B	STM RMI-150/LFB/IEC100-B14 Reducer Only
RM8C	STM RMI-150/LFB/IEC112-B14 Reducer Only
RM8D	STM RMI-150/LFB Reducer with 2.2kW Motor
RM8E	STM RMI-150/LFB Reducer with 4.0kW Motor

*All Reducer/Motor adapters require Gear Ratio option to be 0.

2 Motor Brake

Code	Description
000	No Brake
S1A	1.69 Nm (BE05)
S1B	2.49 Nm (BE05)
S1C	3.50 Nm (BE05)
S2A	4.97 Nm (BE1)
S2B	7.01 Nm (BE1)
S2C	9.94 Nm (BE1)
S3A	9.94 Nm (BE2)
S3B	14.01 Nm (BE2)
S3C	20.00 Nm (BE2)
S4A	20.00 Nm (BE5)
S4B	28.02 Nm (BE5)
S4C	40.00 Nm (BE5)
S4D	55.03 Nm (BE5)

3 Reducer Gear Ratios

Code	Description
7400C	
0	N/A
A	10:1
B	15:1
C	20:1
D	25:1
E	30:1
F	40:1
G	50:1
H	60:1
SEW KH77	
N/A	N/A
9.56:1	10.00:1
15.84:1	14.45:1
20.25:1	19.45:1
29.27:1	31.39:1
40.04:1	36.52:1
51.18:1	49.16:1
58.34:1	63.00:1
73.99:1	70.46:1
SEW KH87	
N/A	N/A
STM RMI-150	
N/A	N/A

*All Reducer/Motor adapters require Gear Ratio option to be 0.
Select Gear ratio column based on the reducer type selected.

*SEW Motor brake setting options only. All other motors use option code 000.

4 Output Clutch & Settings

1800RDM Imperial Clutch Models		M1800RDM Metric Clutch Models	
Code	Description	Code	Description
0000	No Output Overload Clutch	0000	No Output Overload Clutch
61DA	61D, W/23000 In-Lb, SDP*	M61DA	M61D, W/2600 Nm, SDP*
61DB	61D, W/36000 In-Lb, SDP*	M61DB	M61D, W/4070 Nm, SDP*
61DC	61D, W/44000 In-Lb, SDP*	M61DC	M61D, W/4970 Nm, SDP*
61DD	61D, W/50000 In-Lb, SDP*	M61DD	M61D, W/5650 Nm, SDP*
61DE	61D, W/60000 In-Lb, SDP*	M61DE	M61D, W/6780 Nm, SDP*
61DF	61D, W/23000 In-Lb, THDP	M61DF	M61D, W/2600 Nm, THDP
61DG	61D, W/36000 In-Lb, THDP	M61DG	M61D, W/4070 Nm, THDP
61DH	61D, W/44000 In-Lb, THDP	M61DH	M61D, W/4970 Nm, THDP
61DJ	61D, W/50000 In-Lb, THDP	M61DJ	M61D, W/5650 Nm, THDP
61DK	61D, W/60000 In-Lb, THDP	M61DK	M61D, W/6780 Nm, THDP
61EA	61D, W/23000 In-Lb, SDP, EZ*	M61EA	M61D, W/2600 Nm, SDP, EZ*
61EB	61D, W/36000 In-Lb, SDP, EZ*	M61EB	M61D, W/4070 Nm, SDP, EZ*
61EC	61D, W/44000 In-Lb, SDP, EZ*	M61EC	M61D, W/4970 Nm, SDP, EZ*
61ED	61D, W/50000 In-Lb, SDP, EZ*	M61ED	M61D, W/5650 Nm, SDP, EZ*
61EE	61D, W/60000 In-Lb, SDP, EZ*	M61EE	M61D, W/6780 Nm, SDP, EZ*
61EF	61D, W/23000 In-Lb, THDP, EZ	M61EF	M61D, W/2600 Nm, THDP, EZ
61EG	61D, W/36000 In-Lb, THDP, EZ	M61EG	M61D, W/4070 Nm, THDP, EZ
61EH	61D, W/44000 In-Lb, THDP, EZ	M61EH	M61D, W/4970 Nm, THDP, EZ
61EJ	61D, W/50000 In-Lb, THDP, EZ	M61EJ	M61D, W/5650 Nm, THDP, EZ
61EK	61D, W/60000 In-Lb, THDP, EZ	M61EK	M61D, W/6780 Nm, THDP, EZ

* Cannot be used with center post option P.

5 Motor Control

Code	Description
000	NO MOTOR CONTROL
A01	120V 1Ph
A02	(AC) PowerFlex 523 1HP
A03	480V 3Ph
A04	120V 1Ph
A05	(AC) PowerFlex 525 1HP
A06	480V 3Ph
A07	240V 3Ph
A08	(AC) PowerFlex 523 2HP
A09	240V 3Ph
A10	(AC) PowerFlex 525 2HP
A11	240V 3Ph
A12	(AC) PowerFlex 523 3HP
A13	480V 3Ph
A14	(AC) PowerFlex 525 3HP
A15	480V 3Ph
A16	(AC) PowerFlex 523 5HP
A17	600V 3Ph
A18	(AC) PowerFlex 525 5HP
D01	480V 3Ph
D02	(DC) Varipak 1HP 90VDC
D03	Uni-Directional
D04	(DC) Varipak 2HP 180VDC
D05	Bi-Directional
D05	(DC) Cycletrol 3HP 180VDC

Maximum Inertia x 1000 kg-cm ² [lb-in ²] for standard package							
Stops	Motion Time [seconds]						
	0.458	0.611	0.764	0.917	1.222	1.528	1.833
2	0 [0]	0 [0]	23 [8]	79 [27]	266 [91]	533 [182]	749 [256]
3	0 [0]	32 [11]	120 [41]	255 [87]	720 [246]	1381 [472]	1917 [655]
4	3 [1]	91 [31]	249 [85]	495 [169]	1332 [455]	2523 [862]	3488 [1192]
6	56 [19]	243 [83]	577 [197]	1097 [375]	2871 [981]	5390 [1842]	7439 [2542]
8	132 [45]	462 [158]	1056 [361]	1984 [678]	5133 [1754]	9616 [3286]	13257 [4530]
12	351 [120]	1100 [376]	2435 [832]	4518 [1544]	11606 [3966]	21690 [7412]	29881 [10211]
16	656 [224]	1987 [679]	4360 [1490]	8065 [2756]	20666 [7062]	38593 [13188]	53152 [18163]
Reducer Ratio							
	15	20	25	30	40	50	60

Other Motions (stops and index periods) available. Contact your DESTACO sales representative for more information.

Features

- 7400C Reducer (Ratios from 15:1 to 60:1)
- Double Extended Camshaft (Input Shaft)
- Center Thru Hole (Ø165,1 mm [Ø6.50 in.])
- 2 or 3 HP AC Drive Package with Inverter Duty Motor and Inverter Drive (up to 60 cpm)
- Cycle Cam and Limit Switch Mounted to Camshaft
- Right Hand Cam

Output Load Capacity (loads carried during index):

Radial	26022 N [5850 lbs]
Thrust/Axial	61166 N [14650 lbs]
Moment	7696 N-m [68119 in-lb]

Typical Application Dial Diameter:

660 mm [26 in] to 1829 mm [96 in]

Accuracy

±27 arcsec / ±0,15 mm [±.006in]
at 1219,2 mm [48in] Radius

Repeatability

±7 arcsec / ±0,041 mm [±.0016in]
at 1219,2 mm [48in] Radius

Optional Accessories

- 2 hp DC Motor with Varipak DC Motor Control (up to 30 cpm)
- 3 hp DC Motor
- 7500C Heavy Duty Reducer (Ratios from 10:1 to 60:1)
- Output Mechanical Overload Clutch – See Page 39
- EZ Mount Dial Adapter
- Stationary Center Post
- Dual Cam and Limit Switch
- Base Riser Blocks
- Electric Clutch-Brake
- Left Hand Cam
- Relief in Dwell for shot-pin applications

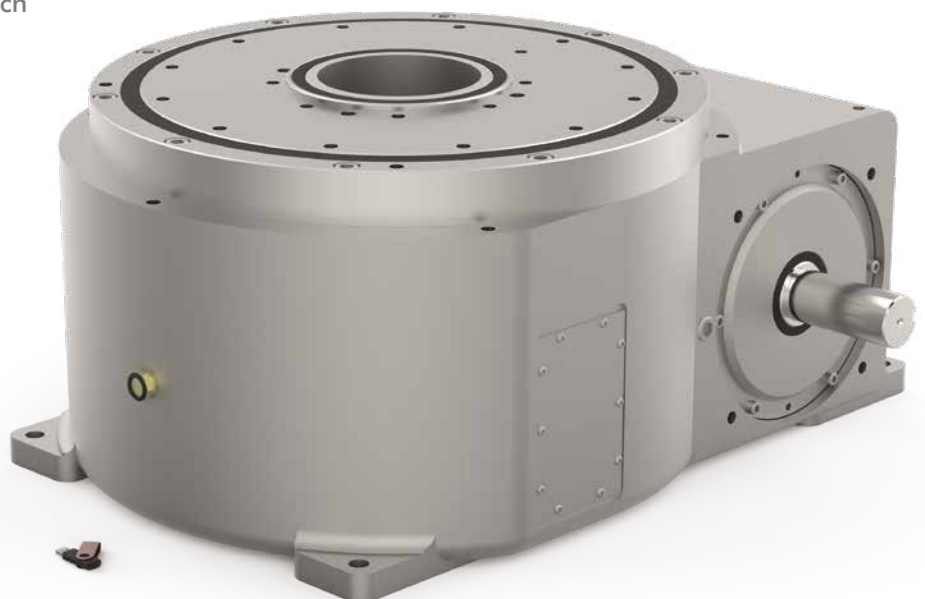

180ORDM SERIES

Rotary Index Drive | Dimensions

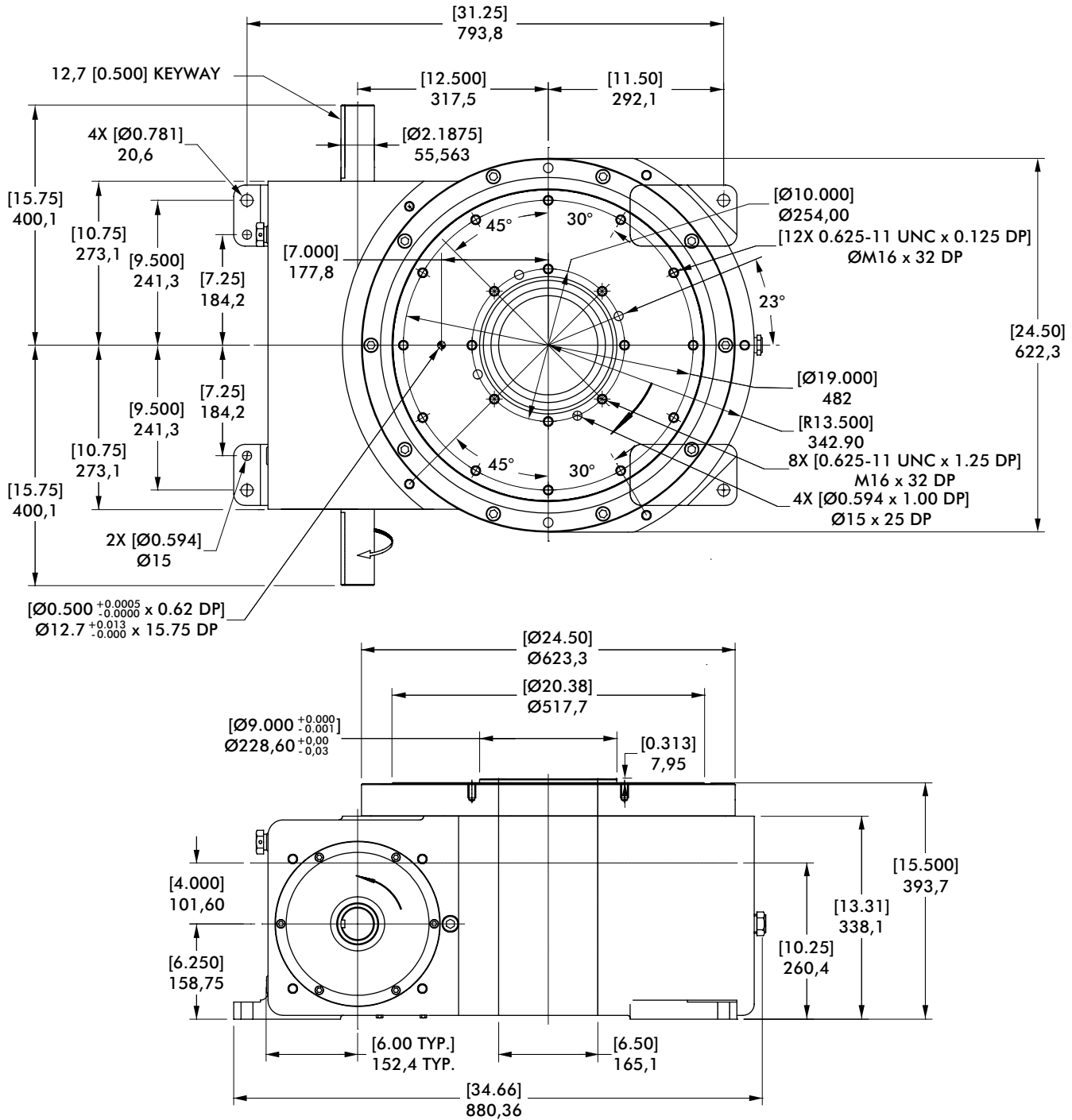

mm [INCH]

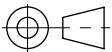

THIRD ANGLE PROJECTION

1800RDM SERIES

Rotary Index Drive | Product Overview | Technical Specifications

Center Post

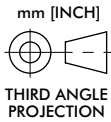
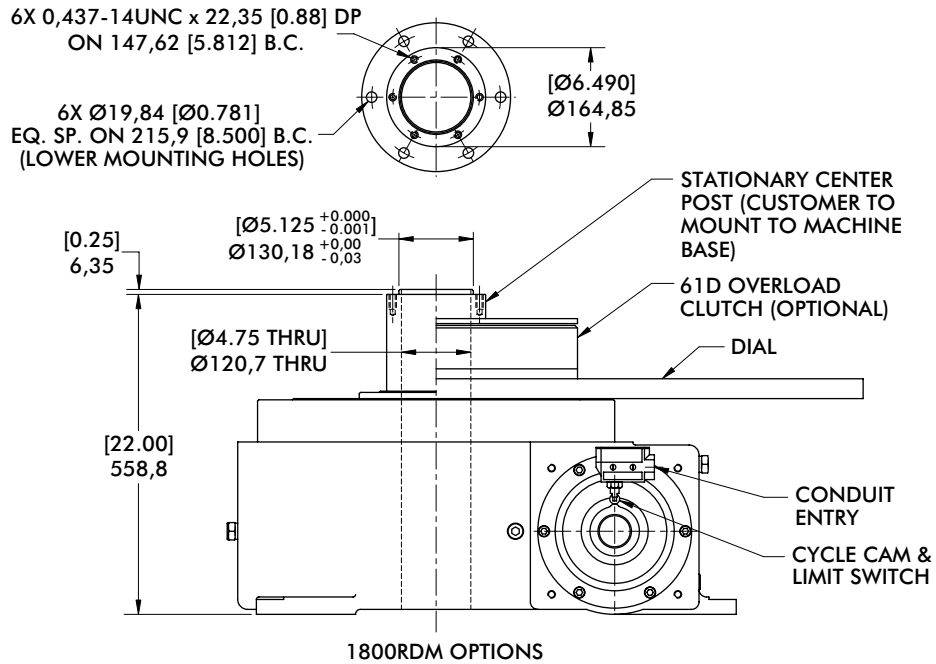

Proximity Switch

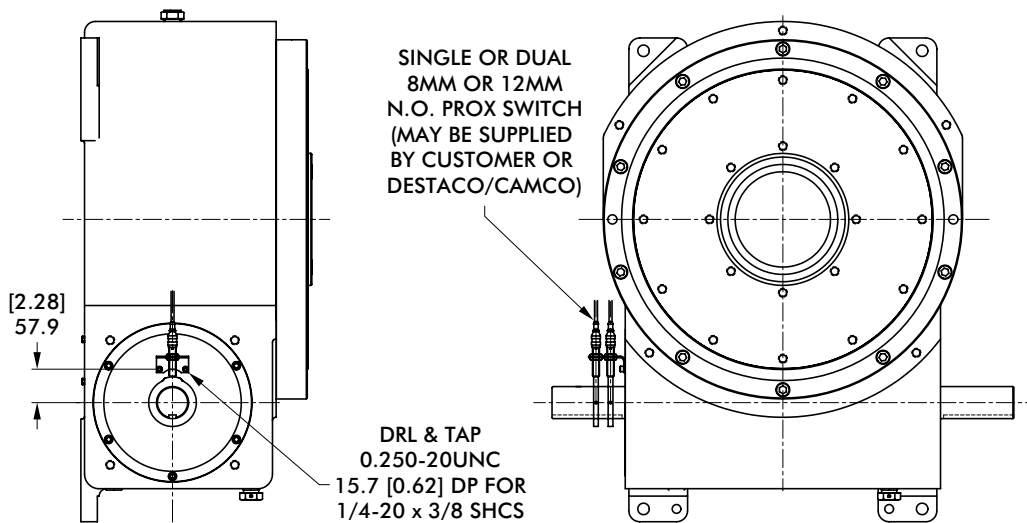

180ORDM SERIES

Rotary Index Drive | Dimensions

61D Overload Clutch

THRU-HOLE CLUTCH

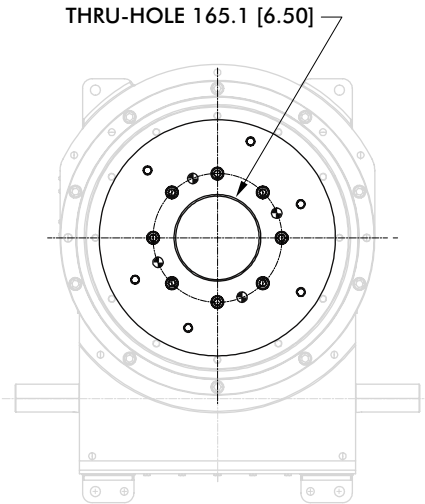

STANDARD CLUTCH

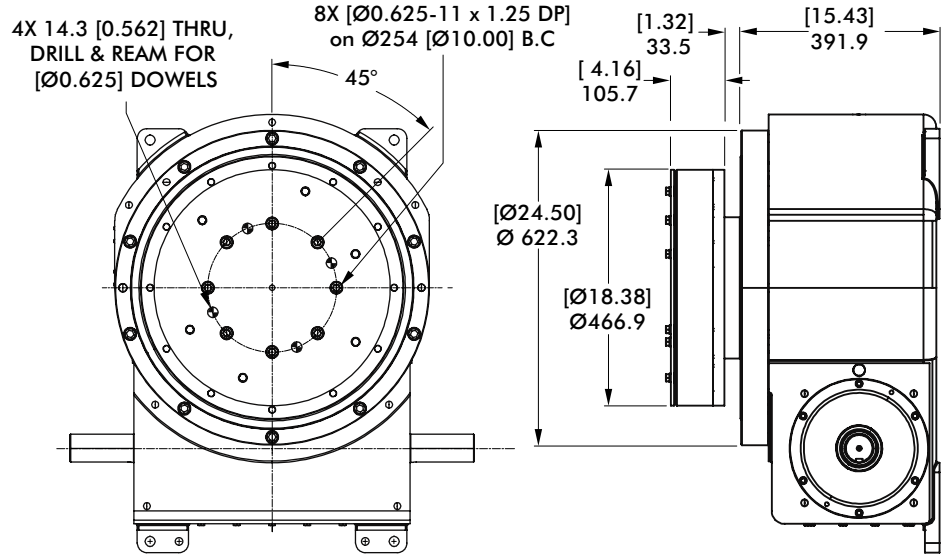

mm [INCH]

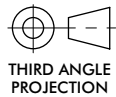

61D Overload Clutch with EZ Dial Mounting Adapter

THRU-HOLE EZ CLUTCH

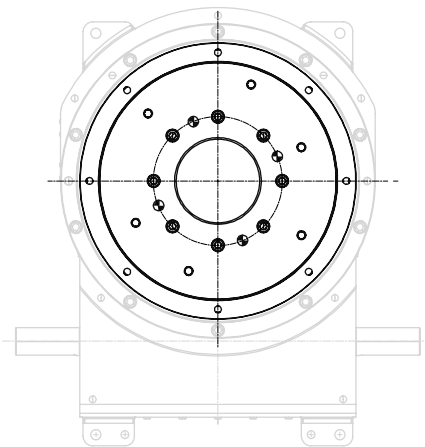

STANDARD EZ CLUTCH

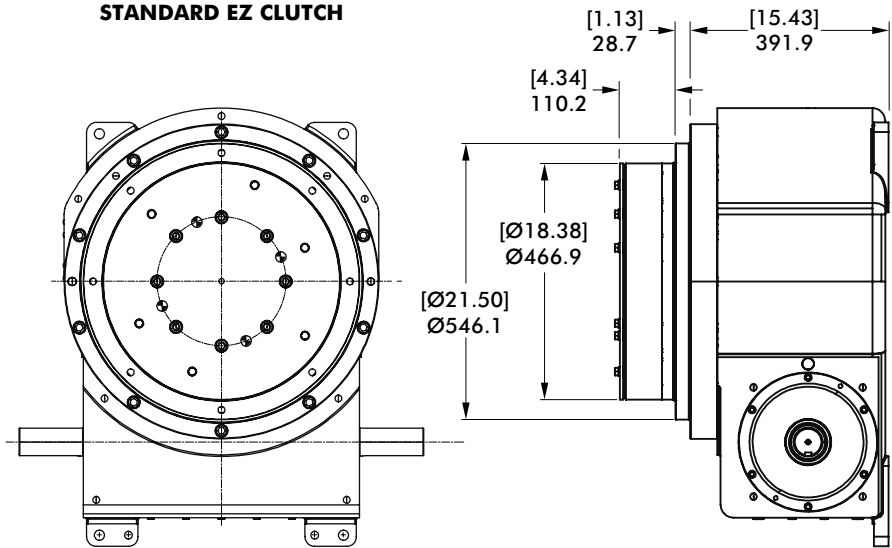

Model	Internal Inertia kg-m ² [lb-in ²]	Torque Setting N-m [in-lb]
61D	1,434 [4900]	2599, 4067, 4971, 5649, 6779 [23000, 36000, 44000, 50000, 60000]

1800RDM SERIES

Notes

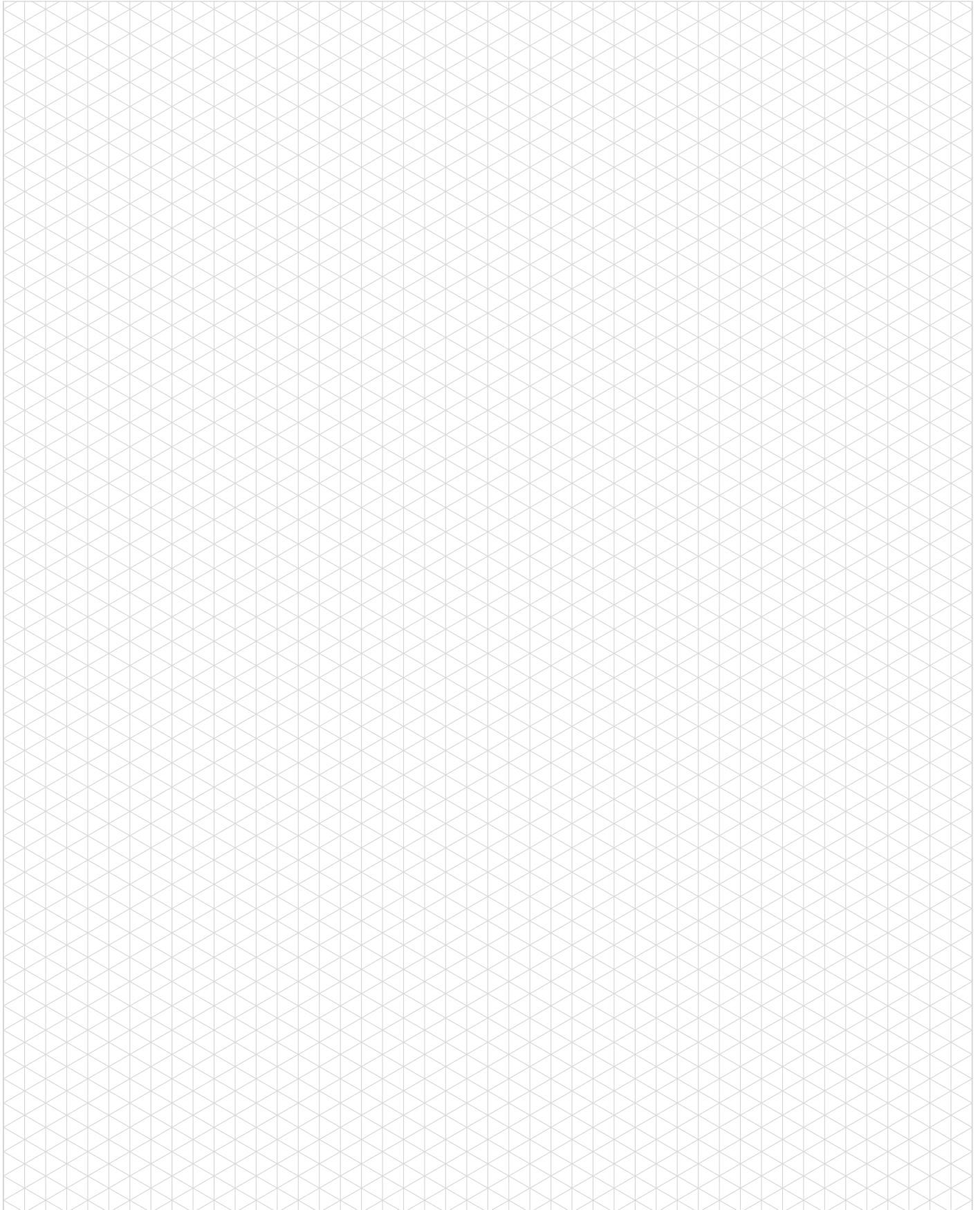

PRECISION INDEXING SOLUTIONS

Table of Contents

INDEXERS

Servo Positioners



GTB Series
Globoidal (Roller Gear)
Servo Positioner.....IN-SRV-1



RSD Series
Rotary Servo Drives.....IN-SRV-39

Mechanical Indexers



RDM Series
Rotary Index Drive IN-MCH-2



RD Series
Roller Dial Index Drive..... IN-MCH-18

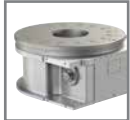

E Series
Heavy-Duty Index Drive IN-MCH-30



RA Series
Right Angle Index Drive IN-MCH-42



RGD/RGS Series
Roller Gear Index Drive IN-MCH-52



P Series
Parallel Shaft/Flange Drive.... IN-MCH-72



RNG Series
Ring Drive Dial Indexer.....IN-MCH-84

OVERLOAD CLUTCHES



Overload Clutches
Output Overload..... IN-CLU-1

CUSTOM CAMS



Custom Cams
Cam Design Solutions IN-CAM-1

CONVEYORS



Rite-Link Series
Thin-Profile.....IN-CNV-1



Precision Link Series
Table-TopIN-CNV-4



Precision Link Series
Heavy-Duty IN-CNV-16

PARTS HANDLERS



LPP Series
Linear Part Handlers IN-PRT-2



RPP Series
Rotary Part Handlers IN-PRT-8

ROLLER DIAL INDEX DRIVES

Features | Table of Contents



Features:

CAMCO Roller Dial Index Drives have a robust, flexible design with superior load capabilities. Other features include:

Short camshaft motion periods, due to oversized roller gear cam design, are well suited for continuous running applications or for special motion requirements such as oscillating motions

Universal mounting including a horizontal mounting ideal for trunnion applications

Option Center Thru-Hole facilitates passage of electrical wiring, pneumatic lines or mechanical linkages

Optional Stationary Center Post with thru-hole provides mounting for upper tool plate

Table of Contents

How to Order	3
425RD	5
800RD	7
1301RD	9
1801RD	11

RD SERIES

Roller Dial Index Drives | How To Order

Base Model Description kW [HP]
425RD w/ R180 reducer & 0.25 [1/3] AC motor (220/440V)
800RD w/ 7300C reducer & 1.49 [2] AC motor (220/440V)
1301RD w/ 7350C reducer & 1.49 [2] AC motor (220/440V)
1801RD w/ 7500C reducer & 2.24 [3] AC motor (220/440V)

Control (only available with these models)

- 1** 1 HP 120V 425RD only
- 2** 1 HP 240V 425RD only
- 3** 1 HP 440V 425RD only
- 4** 2 HP 240V 800RD & 1301RD only
- 5** 2 HP 440V 800RD & 1301RD only
- 6** 3 HP 240V 1801RDM only
- 7** 3 HP 440V 1801RDM only



Motion	Stops	Index Period
A	2	330
B	3	330
C	4	330
D	6	330
E	8	330
F	12	330
G	16	330*

*1301RD & 1801RD

Index Mounting
(See Figure 1)

- 1**
- 2**
- 3**
- 4**
- 5**
- 6**

Reducer Ratio

- A** 15
- B** 20
- C** 25
- D** 30
- E** 40
- F** 50
- G** 60

Reducer Mounting
(See Figure 4)

- A** **J**
- B** **K**
- C** **L**
- D** **M**
- E** **N**
- F** **P**
- G** **R**
- H** **S**

Signal Switch **Signal Switch Side**
(See Figure 2)

M Mechanical **R** Reducer
P Proximity **S** Shaft

Example: MR, MS, PR or PS

Note about signal switch options:

- a) Mechanical is a single switch with cam.
- b) Proximity option is a mounting bracket for 8 or 12 mm proximity switch. A proximity switch will not be supplied. Cam supplied as target.

Other Motions (stops and index periods) available. Contact your DESTACO sales representative for more information.

Input Shaft Configuration/Rotation (Figure 1)

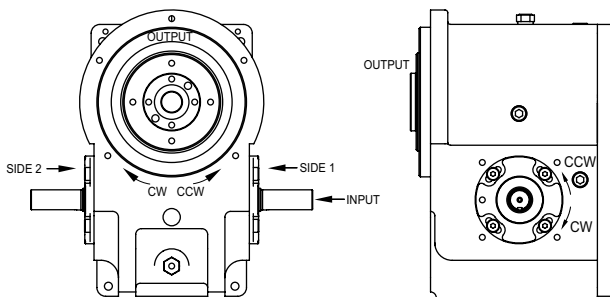

Relative Rotation for Right Hand Cam:

CW Input Side 1 CCW Output
 CCW Input Side 2 CWW Output

NOTE: Input can be driven in either direction

Signal Switch Mounting Position (Figure 2)

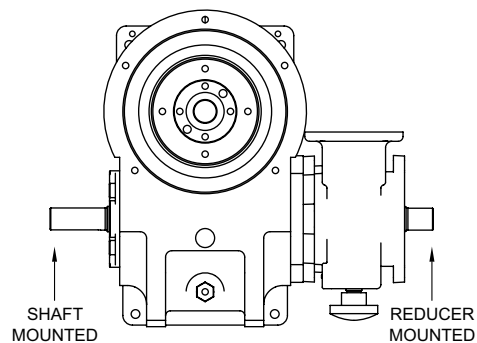

RD SERIES

Roller Dial Index Drives | Input/Output Orientation (Figure 3)

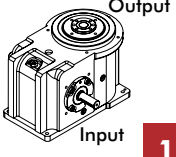
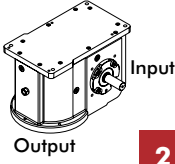
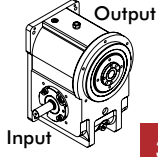
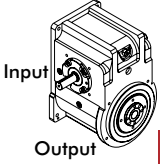
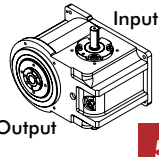
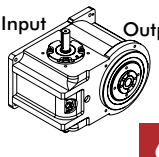
OVOI (output vertical, over input)	OVUI (output vertical, under input)	OHOI (output horizontal, over input)	OHUI (output horizontal, under input)	H-S1-UP (output horizontal, side 1 up)	H-S2-UP (output horizontal, side 2 up)
 <p>Output Input</p> <p>1</p>	 <p>Input Output</p> <p>2</p>	 <p>Output Input</p> <p>3</p>	 <p>Input Output</p> <p>4</p>	 <p>Input Output</p> <p>5</p>	 <p>Input Output</p> <p>6</p>

Gear Reducer Mounting Positions (Figure 4)

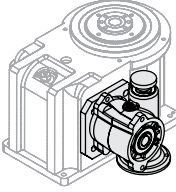
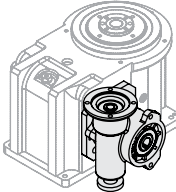
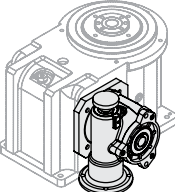
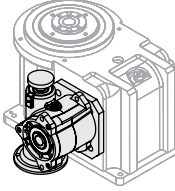
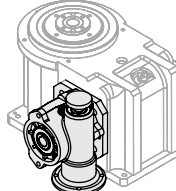
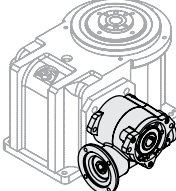
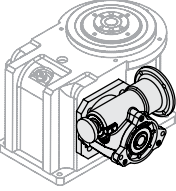
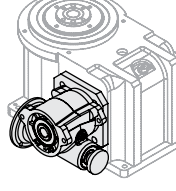
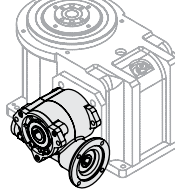
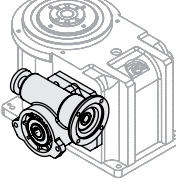
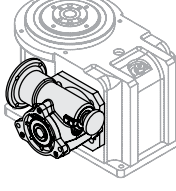
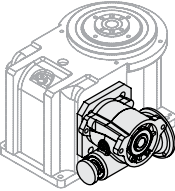
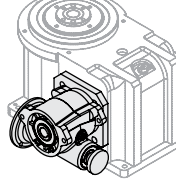
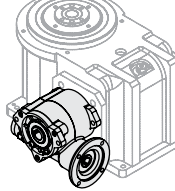
		Mounting "A"		Mounting "B"	
		RD Worm	LD Worm	RD Worm	LD Worm
SIDE 1		A			
		E			
SIDE 2		J			
		N			
		Mounting "C"		Mounting "D"	
		RD Worm	LD Worm	RD Worm	LD Worm
SIDE 1		J		L	M
		N		R	S

Maximum Inertia x 1000 kg-cm ² [lb-in ²] for standard package							
Stops	Motion Time [seconds]						
	0.458	0.611	0.764	0.917	1.222	1.528	1.833
2	0 [0]	3 [1]	6 [2]	12 [4]	32 [11]	47 [16]	64 [22]
3	3 [1]	6 [2]	18 [6]	32 [11]	73 [25]	108 [37]	146 [50]
4	3 [1]	15 [5]	29 [10]	56 [19]	129 [44]	193 [66]	263 [90]
6	12 [4]	32 [11]	70 [24]	129 [44]	293 [100]	439 [150]	457 [156]
8	20 [7]	59 [20]	126 [43]	231 [79]	457 [156]	457 [156]	457 [156]
12	47 [16]	132 [45]	260 [89]	398 [136]	430 [147]	430 [147]	430 [147]
Reducer Ratio							
	15	20	25	30	40	50	60

Features

- R180 Reducer (ratios from 15:1 to 60:1)
 - Double Extended Worm Shaft (Input)
 - Worm Shaft Handwheel
- Double Extended Camshaft (Input Shaft)
- 1/3 HP AC Drive Package with Inverter Duty Motor and IM-pAC AC Drive (up to 60 cpm)
- R225 Reducer with 1 HP AC or DC Motor (ratios of 5:1 to 60:1)
- Cycle Cam and Limit Switch Mounted to Camshaft
- Right Hand Cam

Optional Accessories

- 1/3 hp DC Motor
- Varipak DC Motor Control (up to 30 cpm)
- 2.8D Output Overload Clutch
 - Available Settings (in-lbs): 400, 480, 700, 850, 1100, 1300, 1800, 2200, 3100
- Center Thru Hole (0.81 in. Diameter)
- Stationary Center Post
- Dual Cam and Limit Switch
- Left Hand Cam
- Relief in Dwell for shot-pin applications
- Universal Mounting Capability
- Custom Dial Plate

Output Load Capacity (loads carried during index):

Radial 12010 N [2700 lbs]
 Thrust/Axial 717 N [1600 lbs]
 Moment 655 N-m [5800 in-lbs]

Accuracy

±47 arcsec / ±0,025 mm [±.0027 in] at 304,8 mm [12 in] Radius

Repeatability

±12 arcsec / ±0,018 mm [±.0007 in] at 304,8 mm [12 in] Radius

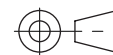
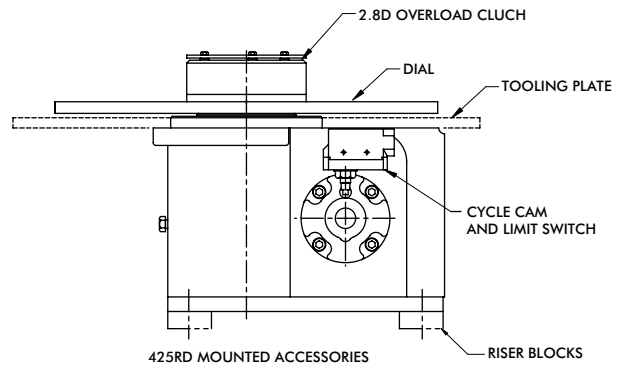

Unless otherwise noted, all dimensions are in inches.

800RD SERIES

Roller Dial Index Drives | Dimensions

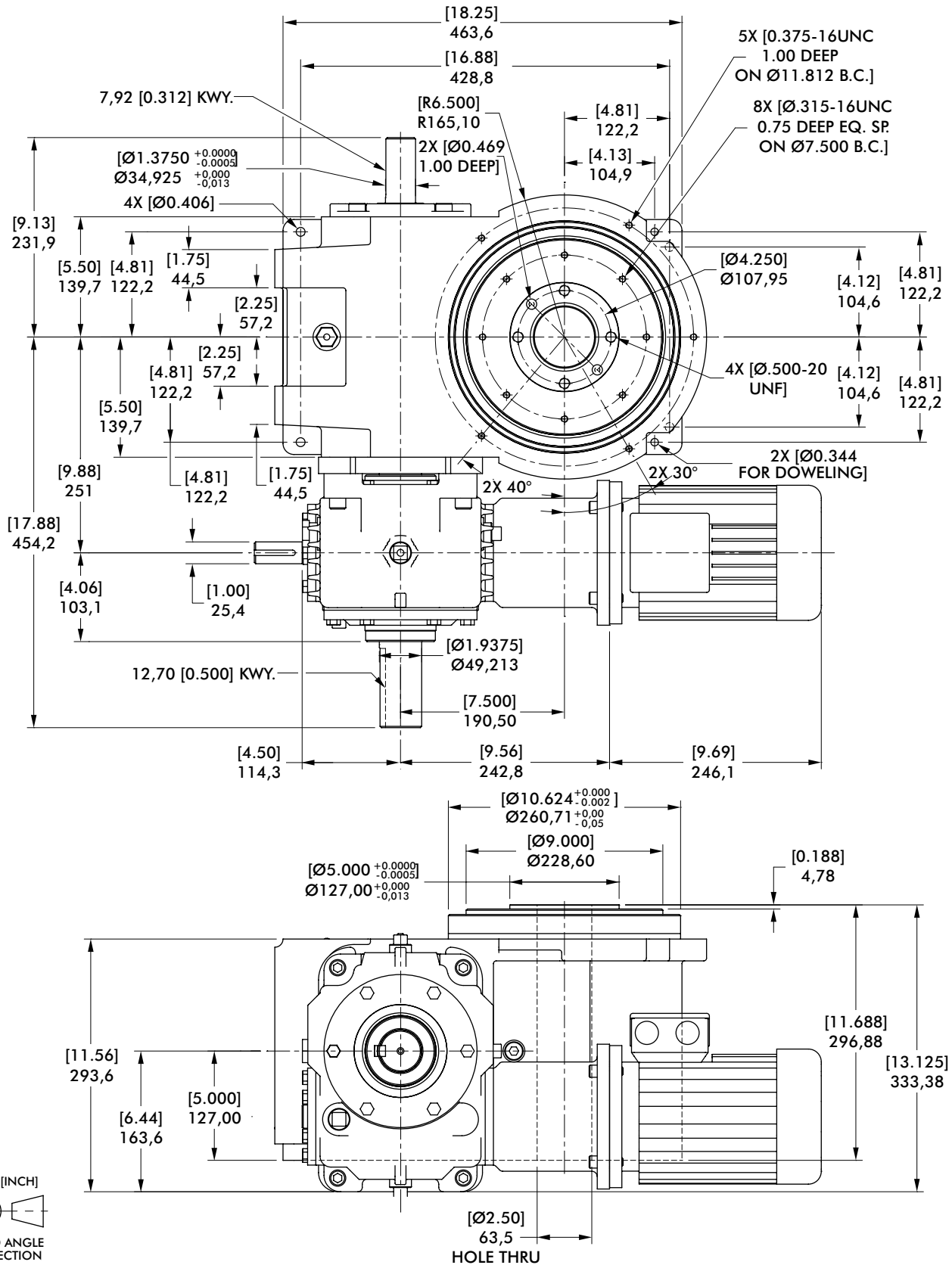

Maximum Inertia x 1000 kg-cm ² [lb-in ²] for standard package							
Stops	Motion Time [seconds]						
	0.458	0.611	0.764	0.917	1.222	1.528	1.833
2	6 [2]	23 [8]	50 [17]	94 [32]	161 [55]	243 [83]	334 [114]
3	20 [7]	56 [19]	117 [40]	211 [72]	366 [125]	547 [187]	755 [258]
4	38 [13]	102 [35]	211 [72]	380 [130]	653 [223]	977 [334]	1343 [459]
6	88 [30]	231 [79]	480 [164]	857 [293]	1475 [504]	2204 [753]	3026 [1034]
8	158 [54]	416 [142]	855 [292]	1525 [521]	2625 [897]	3605 [1232]	3605 [1232]
12	360 [123]	913 [312]	1528 [522]	2324 [794]	3383 [1156]	3383 [1156]	3383 [1156]
Reducer Ratio							
	15	20	25	30	40	50	60

Features

- 7300C Reducer (Ratios from 15:1 to 60:1)
 - Double Extended Worm Shaft (Input)
 - Motor Adapter and Coupling
- Double Extended Camshaft (Input Shaft)
- 1 HP AC Drive Package with Inverter Duty Motor and IM-pAC AC Drive (up to 60 cpm)
- Cycle Cam and Limit Switch Mounted to Camshaft
- Right Hand Cam

Optional Accessories

- 7350C Reducer (ratios from 5:1 to 60:1) with 1 hp AC or DC Motor
- 1 hp DC Motor
- Varipak DC Motor Control (up to 30 cpm)
- Output Overload Clutch model 7.8D
 - Available Settings (in-lbs): 1400, 1700, 2600, 3200, 4200, 5000, 7200, 10,000
- Output Overload Clutch model 18D
 - Available Settings (in-lbs): 5000, 7000, 7800, 10,000, 12,000, 16,000, 19,000, 21,000, 27,000, 42,000, 45,000
- Center Thru Hole (2.50 in. Diameter)
- Stationary Center Post
- Dual Cam and Limit Switch
- Left Hand Cam
- Relief in Dwell for shot-pin applications
- Universal Mounting Capability
- Custom Dial Plate

Output Load Capacity (loads carried during index):

Radial 22139 N [4977 lbs]
 Thrust/Axial 15840 N [3561 lbs]
 Moment 2531 N-m [22398 in-lbs]

Accuracy

±30 arcsec / ±0,102 mm [±.004 in] at 609,6 mm [24 in] Radius

Repeatability

±8 arcsec / ±0,023 mm [±.0009 in] at 609,6 mm [24 in] Radius

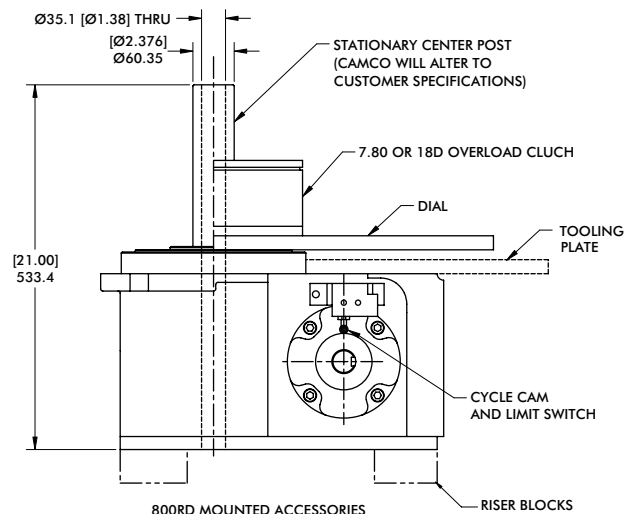

Unless otherwise noted, all dimensions are in inches.

1301RD SERIES

Roller Dial Index Drives | Dimensions

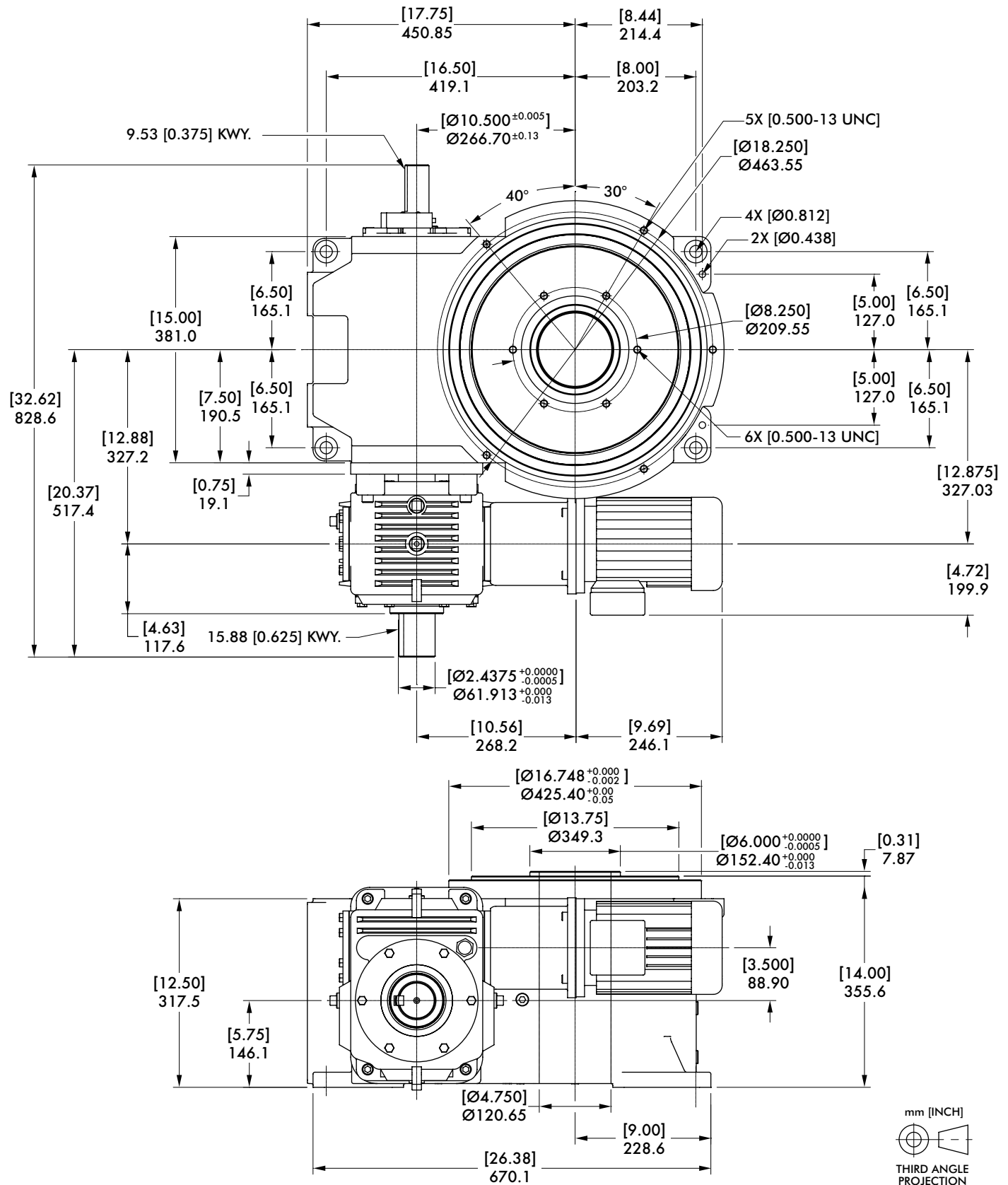

Maximum Inertia x 1000 kg-cm ² [lb-in ²] for standard package							
Stops	Motion Time [seconds]						
	0.458	0.611	0.764	0.917	1.222	1.528	1.833
2	0 [0]	15 [5]	44 [15]	85 [29]	149 [51]	228 [78]	316 [108]
3	12 [4]	47 [16]	108 [37]	199 [68]	348 [119]	524 [179]	720 [246]
4	29 [10]	91 [31]	196 [67]	360 [123]	626 [214]	939 [321]	1288 [440]
6	76 [26]	214 [73]	454 [155]	822 [281]	1419 [485]	2122 [725]	2912 [995]
8	140 [48]	386 [132]	814 [278]	1472 [503]	2531 [865]	3778 [1291]	5183 [1771]
12	325 [111]	881 [301]	1844 [630]	3321 [1135]	5709 [1951]	8513 [2909]	11673 [3989]
16	588 [201]	1574 [538]	3283 [1122]	5911 [2020]	10158 [3471]	15141 [5174]	20757 [7093]
Reducer Ratio							
	15	20	25	30	40	50	60

Features

- 7350C Reducer (Ratios from 15:1 to 60:1)
 - Double Extended Worm Shaft (Input)
 - Motor Adapter and Coupling
- Double Extended Camshaft (Input Shaft)
- 2 HP AC Drive Package with Inverter Duty Motor and Inverter Drive (up to 60 cpm)
- Cycle Cam and Limit Switch Mounted to Camshaft
- Right Hand Cam

Optional Accessories

- 7400C Reducer (Ratios from 5:1 to 60:1) with Motor Adapter and Coupling
- 2 hp DC Motor
- Varipak DC Motor Control (up to 30 cpm)
- Output Overload Clutch model 31D
 - Available Settings (in-lbs): 8500, 13,000, 20,000, 31,000
- Center Thru Hole (4.75 in. Diameter)
- Stationary Center Post
- Dual Cam and Limit Switch
- Left Hand Cam
- Relief in Dwell for shot-pin applications
- Universal Mounting Capability
- Custom Dial Plate

Output Load Capacity (loads carried during index):

Radial 70282 N [15800 lbs]
 Thrust/Axial 48041N [10800 lbs]
 Moment 12315 N-m [109000 in-lbs]

Accuracy ±39 arcsec / ±0,173 mm [±.0068 in] at 914,4 mm [36 in] Radius

Repeatability ±10 arcsec / ±0,043 mm [±.0017 in] at 914,4 mm [36 in] Radius

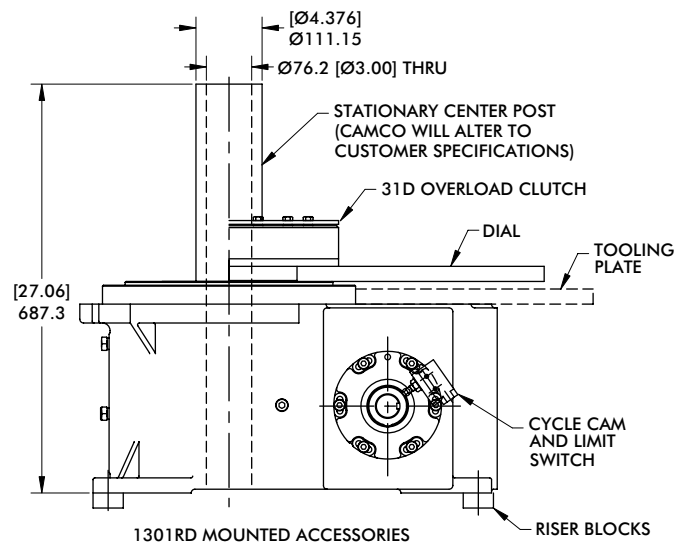

Unless otherwise noted, all dimensions are in inches.

1801RD SERIES

Roller Dial Index Drives | Dimensions

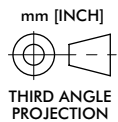
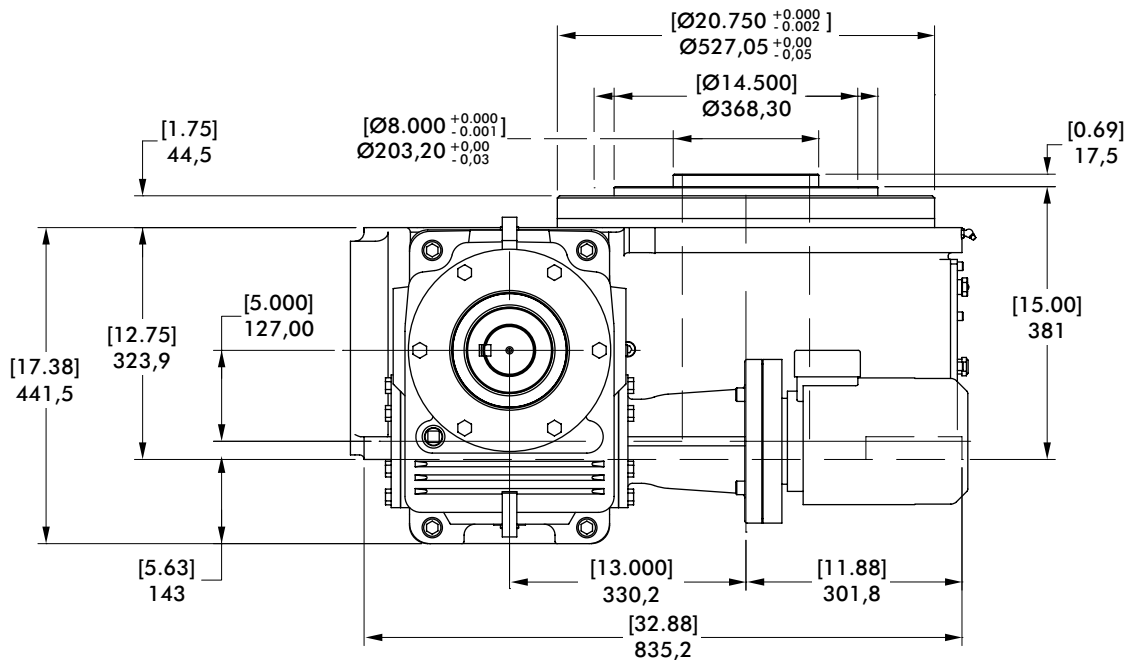
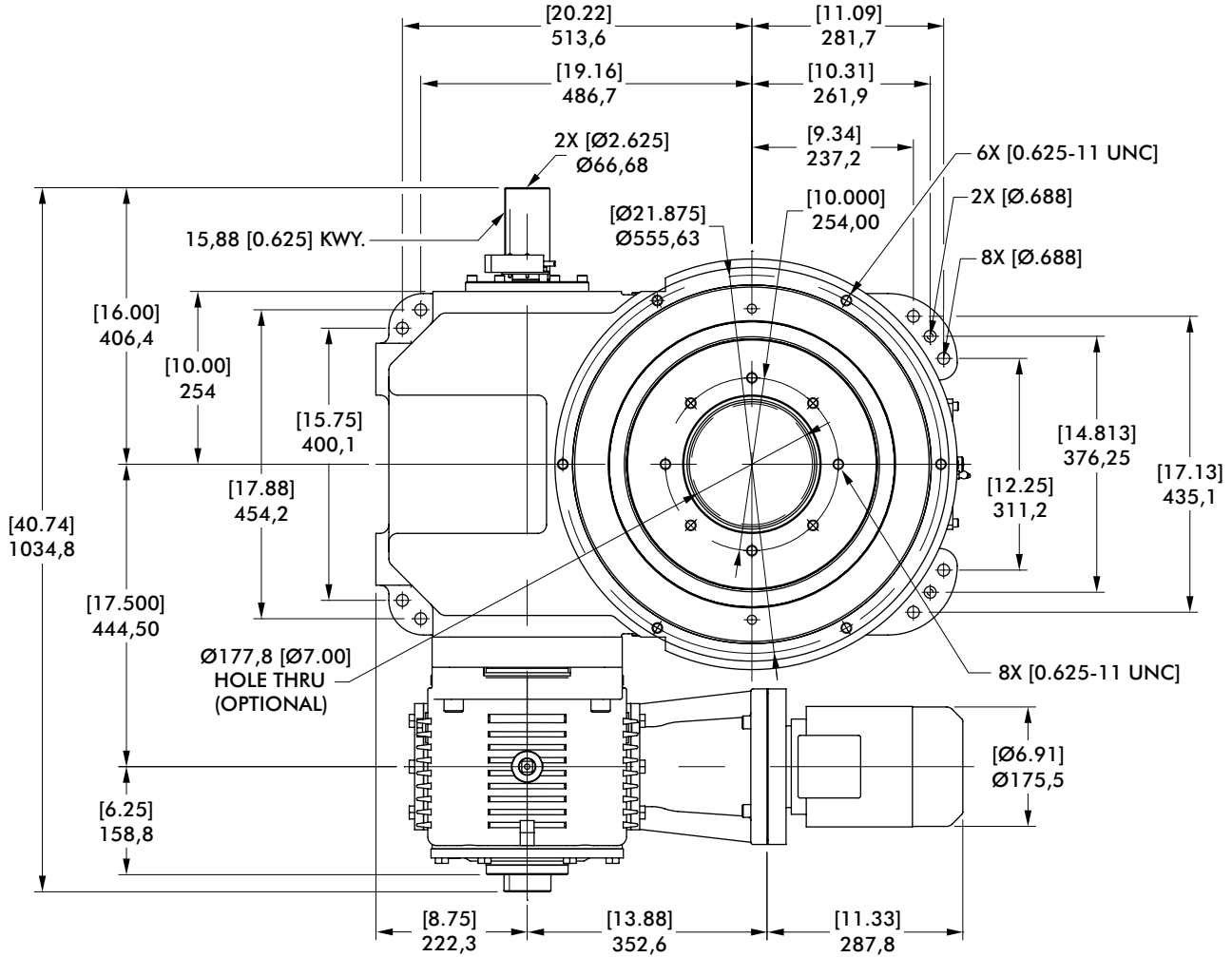

Maximum Inertia x 1000 kg-cm ² [lb-in ²] for standard package							
Stops	Motion Time [seconds]						
	0.458	0.611	0.764	0.917	1.222	1.528	1.833
2	0 [0]	15 [5]	53 [18]	114 [39]	319 [109]	670 [229]	1,206 [412]
3	6 [2]	50 [17]	129 [44]	252 [86]	673 [230]	1,393 [476]	2,487 [850]
4	26 [9]	114 [39]	269 [92]	512 [175]	1,340 [458]	2,748 [939]	4,893 [1,672]
6	79 [27]	266 [91]	600 [205]	1,121 [383]	2,894 [989]	5,914 [2,021]	10,515 [3,593]
8	158 [54]	492 [168]	1,083 [370]	2,010 [687]	5,159 [1,763]	10,529 [3,598]	18,708 [6,393]
12	372 [127]	1,121 [383]	2,455 [839]	4,542 [1,552]	11,627 [3,973]	23,710 [8,102]	42,114 [14,391]
16	679 [232]	2,010 [687]	4,384 [1,498]	8,091 [2,765]	20,690 [7,070]	42,17 [1,441]	56,933 [19,455]
Reducer Ratio							
	15	20	25	30	40	50	60

Features

- 7500C Reducer (Ratios from 15:1 to 60:1)
 - Double Extended Worm Shaft (Input)
 - Motor Adapter and Coupling
- Double Extended Camshaft (Input Shaft)
- 3 HP AC Drive Package with Inverter Duty Motor and Inverter Drive (up to 60 cpm)
- Cycle Cam and Limit Switch Mounted to Camshaft
- Right Hand Cam

Optional Accessories

- 7600C or 7700C Reducer (Ratios from 5:1 to 60:1) with Motor Adapter and Coupling
- 3 hp DC Motor
- Output Overload Clutch model 62D
 - Available Settings (in-lbs): 23,000, 36,000, 44,000, 50,000, 60,000
- Center Thru Hole (7.00 in. Diameter)
- Stationary Center Post
- Dual Cam and Limit Switch
- Left Hand Cam
- Relief in Dwell for shot-pin applications
- Custom Dial Plate

Output Load Capacity (loads carried during index):

Radial 65,834 N [14,800 lbs]
 Thrust/Axial 56,048 N [12,600 lbs]
 Moment 12,089 N-m [107,000 in-lbs]

Accuracy ±27 arcsec / ±.160 mm [±.0063 in] at 1,219.2 mm [48 in] Radius

Repeatability ±7 arcsec / ±.041 mm [±.0016 in] at 1,219.2 mm [48 in] Radius

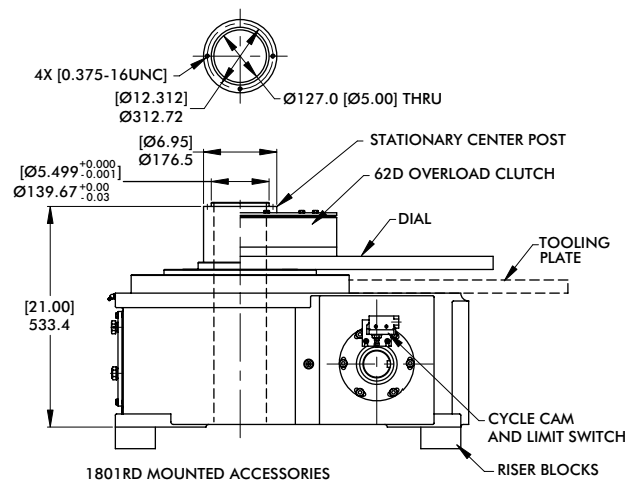

Unless otherwise noted, all dimensions are in inches.

PRECISION INDEXING SOLUTIONS

Table of Contents

INDEXERS

Servo Positioners



GTB Series
Globoidal (Roller Gear)
Servo Positioner.....IN-SRV-1



RSD Series
Rotary Servo Drives.....IN-SRV-39

Mechanical Indexers



RDM Series
Rotary Index Drive IN-MCH-2



RD Series
Roller Dial Index Drive..... IN-MCH-18



E Series
Heavy-Duty Index Drive IN-MCH-30



RA Series
Right Angle Index Drive IN-MCH-42



RGD/RGS Series
Roller Gear Index Drive IN-MCH-52



P Series
Parallel Shaft/Flange Drive.... IN-MCH-72



RNG Series
Ring Drive Dial Indexer.....IN-MCH-84

OVERLOAD CLUTCHES



Overload Clutches
Output Overload..... IN-CLU-1

CUSTOM CAMS



Custom Cams
Cam Design Solutions IN-CAM-1

CONVEYORS



Rite-Link Series
Thin-Profile.....IN-CNV-1



Precision Link Series
Table-TopIN-CNV-4



Precision Link Series
Heavy-Duty IN-CNV-16

PARTS HANDLERS



LPP Series
Linear Part Handlers IN-PRT-2



RPP Series
Rotary Part Handlers IN-PRT-8

HEAVY DUTY INDEX DRIVE

Table of Contents



Features:

The **CAMCO E-Series Heavy Duty Index Drive** is ideal for heavy-duty rotary dial applications with features including:

Large output mounting surface supported by a 4-point contact bearing providing superior thrust and moment capacity

Large center thru-hole to accommodate stationary center post, electrical wiring and air or hydraulic lines

Complete motorized drive package with reducer and AC inverter drive to suit most applications

Precision cam with preloaded cam followers for maximum accuracy

Durable welded steel housing

Preloaded "center rib" design for smooth acceleration and deceleration with precision positioning

Table of Contents

How to Order	3
750E.....	5
950E.....	7
1150E.....	9
1550E.....	11

E-SERIES

Heavy Duty Index Drive | How To Order

Base Model Description

750E w/ KH87 reducer & 12.5 HP AC motor (220/440V)

950E w/ KH87 reducer & 15 HP AC motor (220/440V)

1150E w/ KH107 reducer & 25 HP AC motor (220/440V)

1550E w/ KH127 reducer & 30 HP AC motor (220/440V)

Control (only available with these models)

1 15 HP 240V 750E & 950E only

2 15 HP 440V 750E & 950E only

3 25 HP 240V 1150E only

4 25 HP 440V 1150E only

5 30 HP 240V 1550E only

6 30 HP 440V 1550E only

Motion	Stops	Index Period
A	2	330
B	3	330
C	4	330
D	6	330
E	8	330
F	12	330
G	16	330

Index Mounting	Reducer Ratio			
(See Figure 1)	750E	950E	1150E	1550E
1	A	14.50	29.00	40.19
2	B	19.95	42.33	54.07
3	C	24.92	49.90	70.95
4	D	31.39	52.17	81.98
5	E	44.02	66.52	89.89
6	F	49.16	73.30	110.18
	G	63.00	82.61	122.98

Reducer Mounting	Signal Switch	Signal Switch Side
(See Figure 3)		(See Figure 2)
A	M Mechanical	S Shaft
	P Proximity	

Example: MS or PS

Note about signal switch options:

a) Mechanical is a single switch with cam.

b) Proximity option is a mounting bracket for 8 or 12 mm proximity switch. A proximity switch will not be supplied. Cam supplied as target.

Other Motions (stops and index periods) available. Contact your DESTACO sales representative for more information.

Input Shaft Configuration/Rotations (Figure 1)

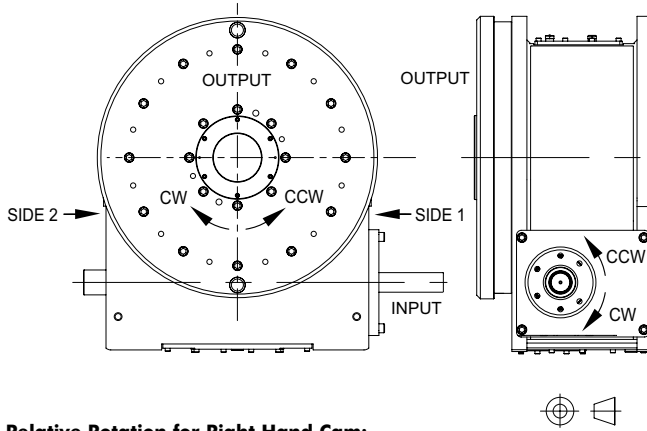

Relative Rotation for Right Hand Cam:

CW Input Side 1 CCW Output
CCW Input Side 2 CW Output

NOTE: Input can be driven in either direction

Signal Switch Mounting Position (Figure 2)

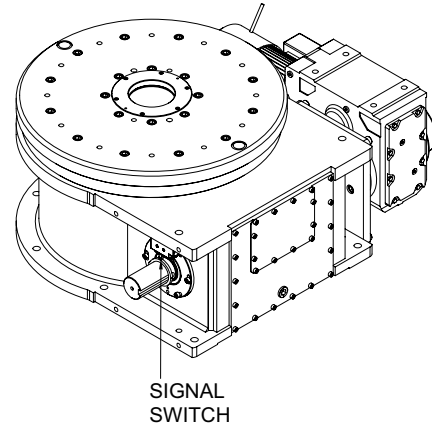

Gear Reducer Mounting Position (Figure 3)

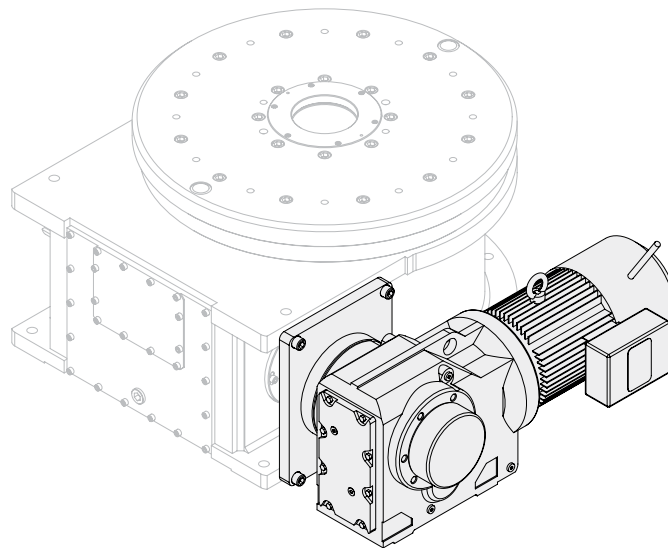

750E SERIES

Heavy Duty Index Drive | Dimensions

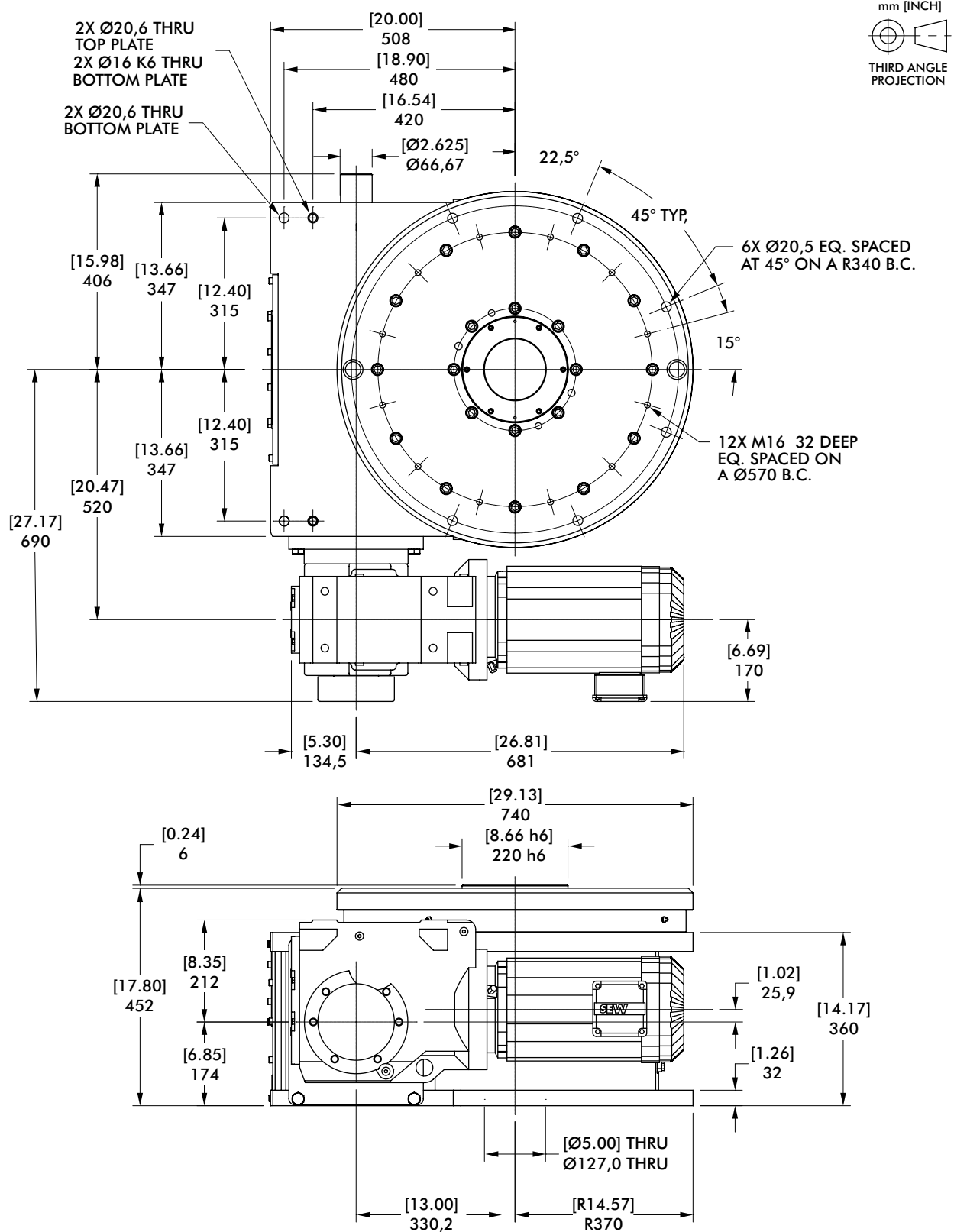

Maximum Inertia x 1000 [lb-in ²] kg-cm ² for standard package							
Stops	Motion Time [seconds]						
	0.44	0.59	0.76	0.96	1.35	1.50	1.93
2	[0] 0	[27] 79	[105] 307	[254] 743	[751] 2198	[987] 2888	[1647] 4820
3	[14] 41	[98] 287	[257] 752	[562] 1645	[1577] 4615	[2058] 6023	[3407] 9970
4	[67] 196	[231] 676	[542] 1586	[1140] 3336	[3128] 9154	[4072] 11916	[6714] 19648
6	[191] 559	[542] 1586	[1209] 3538	[2491] 7290	[6756] 19771	[8781] 25697	[14447] 42278
8	[372] 1089	[931] 2724	[1677] 4908	[2841] 8314	[5587] 16350	[6968] 20391	[11444] 33490
12	[886] 2593	[2291] 6704	[4840] 14164	[8195] 23982	[16116] 47162	[20100] 58821	[33010] 96600
16	[1351] 3954	[2717] 7951	[4837] 14155	[8254] 24154	[16263] 47592	[20283] 59356	[33311] 97481
Reducer Ratio							
	14.45	19.45	24.92	31.39	44.02	49.16	63.00

Features

- KH87 Gear Reducer with Brake-motor
- Double Extended Camshaft (Input shaft)
- Center Thru Hole (Ø127 mm [Ø5 in])
- Cycle Cam and Limit Switch
- Right Hand Cam

Optional Accessories

- Left Hand Cam
- Relief in Dwell for Shot-Pin applications
- Dual Cam & limit Switch
- KH97 Gear Reducer with Brake-motor
- Stationary Center Post
- Visual Disk Dwell Indicator

Output Load Capacity (loads carried during index):

Radial	129888 N [29200 lbs]
Thrust/Axial	186825 N [42000 lbs]
Moment	46830 N-m [414500 in-lbs]

Typical Application Dial Diameter:

1397 mm to 2794 mm [55 in to 110 in]

Accuracy

±27 arcsec / ±.0,05 mm [±.002 in]
at 381 mm [15in] Radius

Repeatability

±7 arcsec / ±.0,013 mm [±.0005 in]
at 381 mm [15in] Radius

950E SERIES

Heavy Duty Index Drive | Dimensions

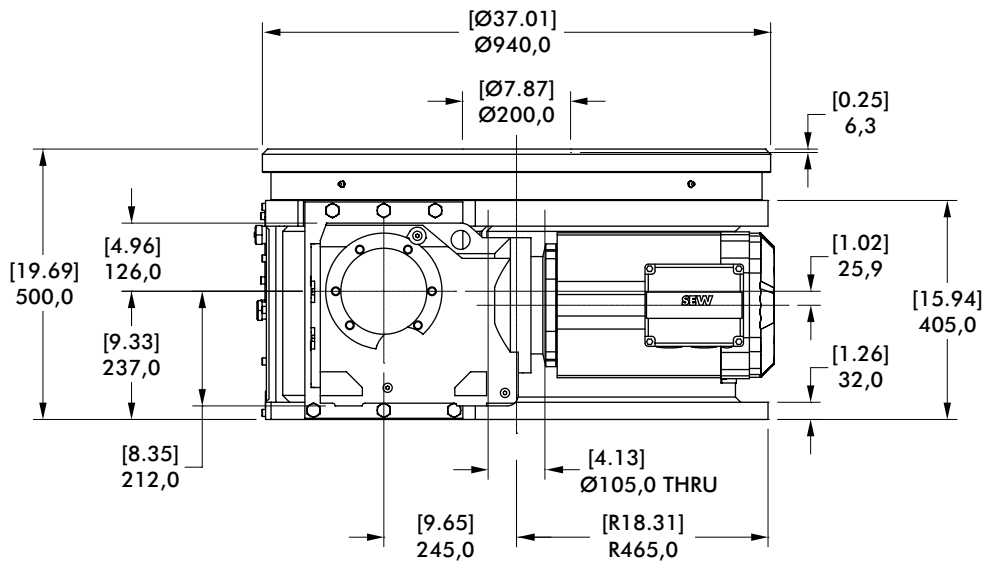
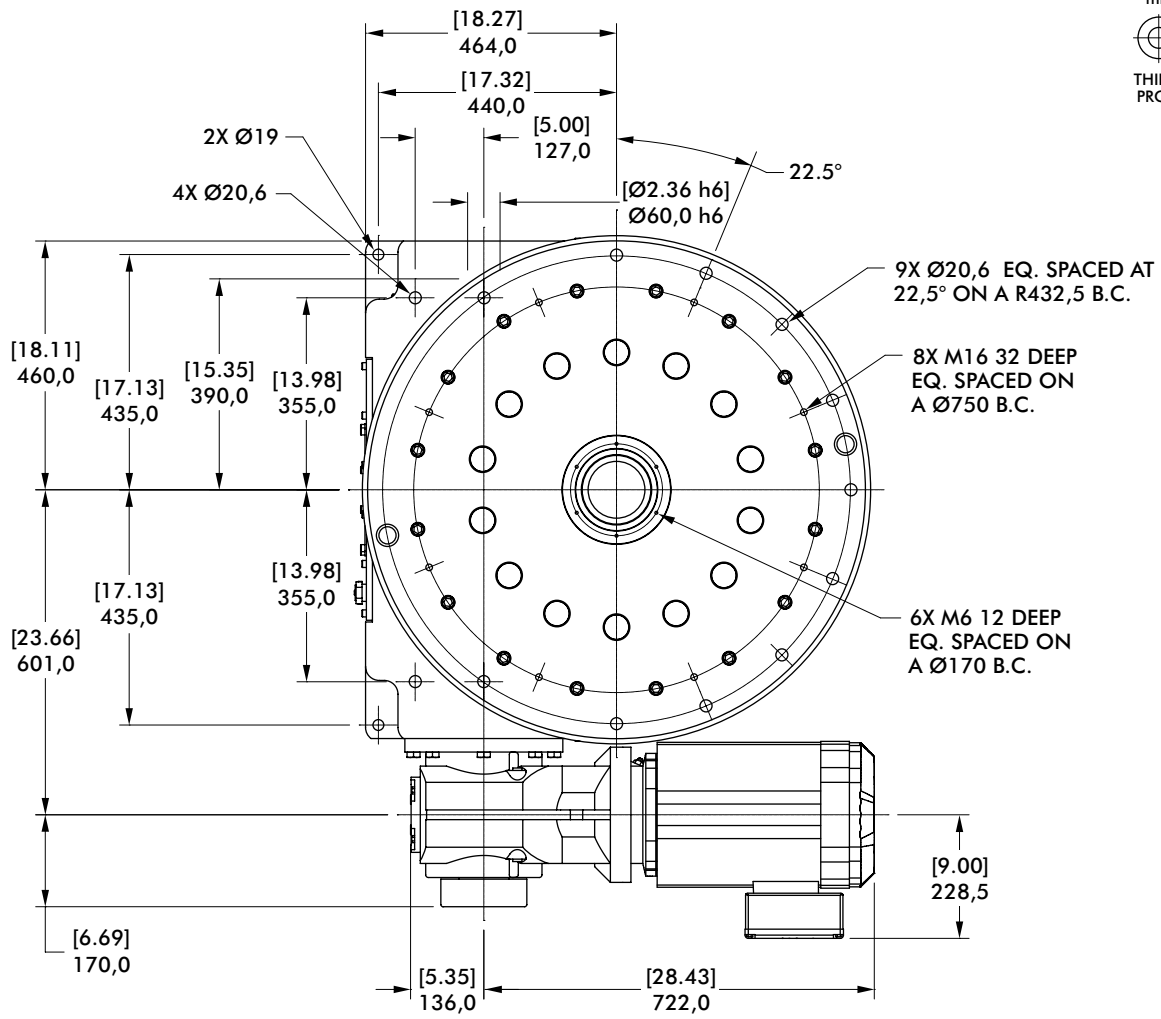

Maximum Inertia x 1000 [lb-in ²] kg-cm ² for standard package							
Stops	Motion Time [seconds]						
	0.44	0.59	0.76	0.96	1.35	1.50	1.93
2	[0] 0	[0] 0	[61] 179	[224] 656	[619] 1811	[833] 2438	[1433] 4194
3	[0] 0	[59] 173	[250] 732	[619] 1811	[1507] 4410	[1989] 5821	[3337] 9765
4	[16] 47	[205] 600	[564] 1650	[1252] 3664	[2911] 8519	[3810] 11150	[6329] 18521
6	[187] 547	[634] 1855	[1479] 4328	[3102] 9078	[7013] 20523	[9135] 26733	[15073] 44110
8	[412] 1206	[1169] 3421	[2603] 7617	[5287] 15472	[11478] 33589	[14315] 41891	[23511] 68803
12	[1025] 3000	[2729] 7986	[5956] 17430	[10793] 31585	[23621] 69124	[30484] 89208	[53172] 155602
16	[1290] 3775	[2647] 7746	[4753] 13909	[8147] 23841	[17305] 50641	[21582] 63157	[35445] 103726
Reducer Ratio							
	14.45	19.45	24.92	31.39	44.02	49.16	63.00

Features

- KH87 Gear Reducer with Brake-motor
- Double Extended Camshaft (Input shaft)
- Center Thru Hole (Ø105 mm [Ø4.13 in])
- Cycle Cam and Limit Switch
- Right Hand Cam

Optional Accessories

- Left Hand Cam
- Relief in Dwell for Shot-Pin applications
- Dual Cam & limit Switch
- KH97 Gear Reducer with Brake-motor
- Stationary Center Post
- Visual Disk Dwell Indicator

Output Load Capacity (loads carried during index):

Radial	233976 N [52600 lbs]
Thrust/Axial	337397 N [75850 lbs]
Moment	110438 N-m [977500 in-lbs]

Typical Application

Dial Diameter: 1778 mm to 3556 mm [70 in to 140 in]

Accuracy ±29 arcsec / ±0,058 mm [±.0023 in] at 762 mm [30in] Radius

Repeatability ±6 arcsec / ±0,015 mm [±.0006 in] at 762 mm [30in] Radius

1150E SERIES

Heavy Duty Index Drive | Dimensions

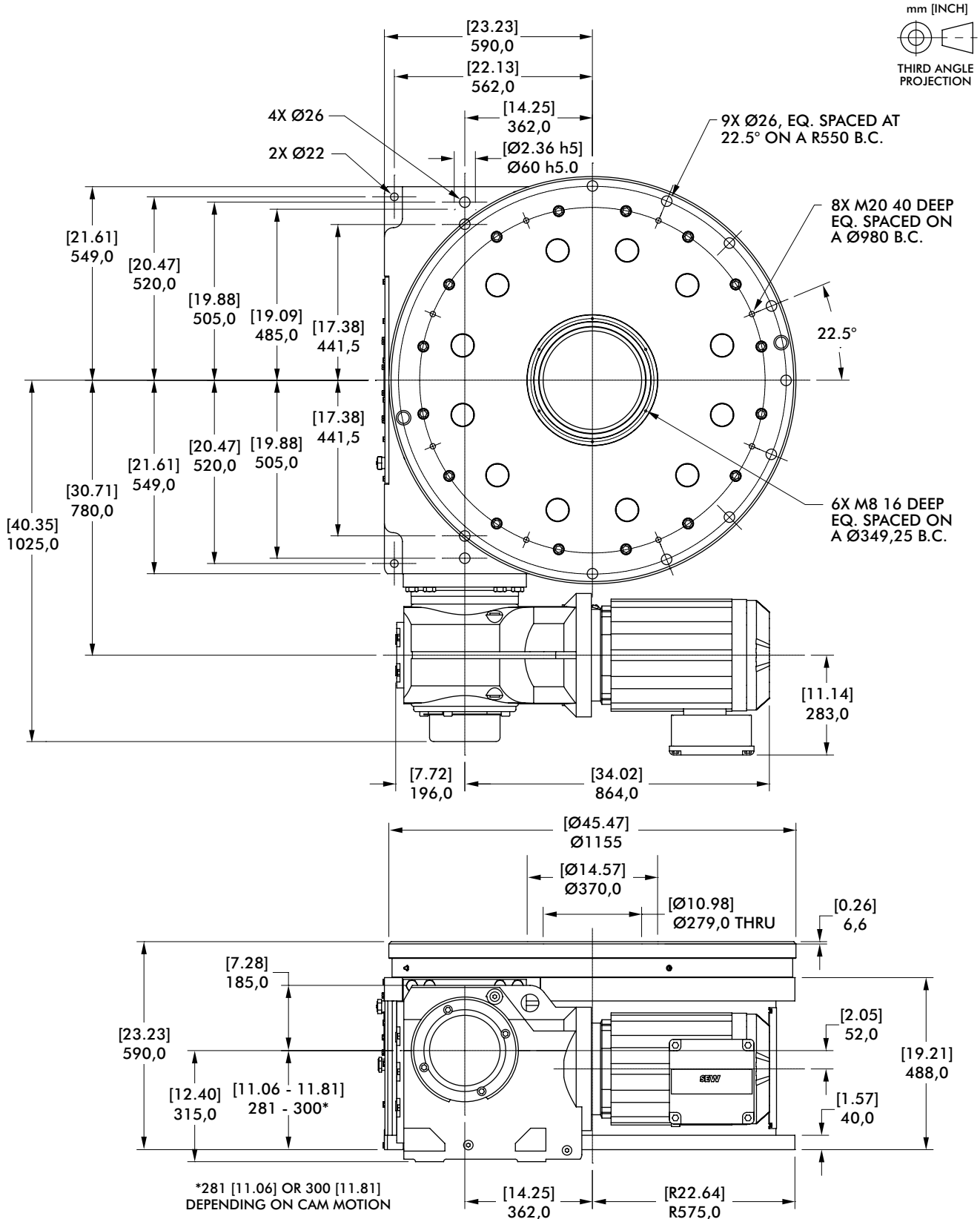

Maximum Inertia x 1000 kg-cm ² [lb-in ²] for standard package							
Stops	Motion Time [seconds]						
	0.89	1.29	1.52	1.75	2.03	2.24	2.52
2	[134] 392	[1141] 3339	[2093] 6125	[3329] 9742	[4746] 13889	[5835] 17076	[7501] 21951
3	[698] 2043	[2965] 8677	[5108] 14948	[7887] 23080	[11077] 32416	[13526] 39582	[17275] 50554
4	[1445] 4229	[5474] 16019	[9284] 27169	[14225] 41628	[19896] 58224	[24249] 70962	[30915] 90470
6	[3780] 11062	[12845] 37590	[21419] 62680	[32537] 95216	[45296] 132554	[55090] 161215	[70088] 205105
8	[6581] 19259	[21959] 64261	[36502] 106819	[54381] 159140	[73624] 215453	[89397] 261611	[113548] 332286
12	[15621] 45713	[50221] 146967	[82944] 242727	[123772] 362206	[167569] 490373	[203468] 595428	[258436] 756286
16	[27975] 81866	[61083] 178753	[84884] 248404	[111420] 326059	[150846] 441435	[183162] 536005	[232645] 680812
Reducer Ratio							
	29.00	42.33	49.90	57.17	66.52	73.30	82.61

Features

- KH107 Gear Reducer with Brake-motor
- Double Extended Camshaft (Input shaft)
- Center Thru Hole (Ø278 mm [Ø10.94 in])
- Cycle Cam & limit Switch
- Right Hand Cam

Optional Accessories

- Left Hand Cam
- Relief in Dwell for Shot-Pin applications
- Dual Cam & limit Switch
- KH127 Gear Reducer with Brake-motor
- Stationary Center Post
- Visual Disk Dwell Indicator

Output Load Capacity (loads carried during index):

Radial	262556 N [59025 lbs]
Thrust/Axial	380189 N [85470 lbs]
Moment	165968 N-m [1469000 in-lbs]

Typical Application

Dial Diameter: 2286 mm to 4572 mm [90 in to 180 in]

Accuracy ±16 arcsec / ±0,05 mm [±.002 in] at 635 mm [25in] Radius

Repeatability ±4 arcsec / ±0,013 mm [±.0005 in] at 635 mm [25in] Radius

1550E SERIES

Heavy Duty Index Drive | Dimensions

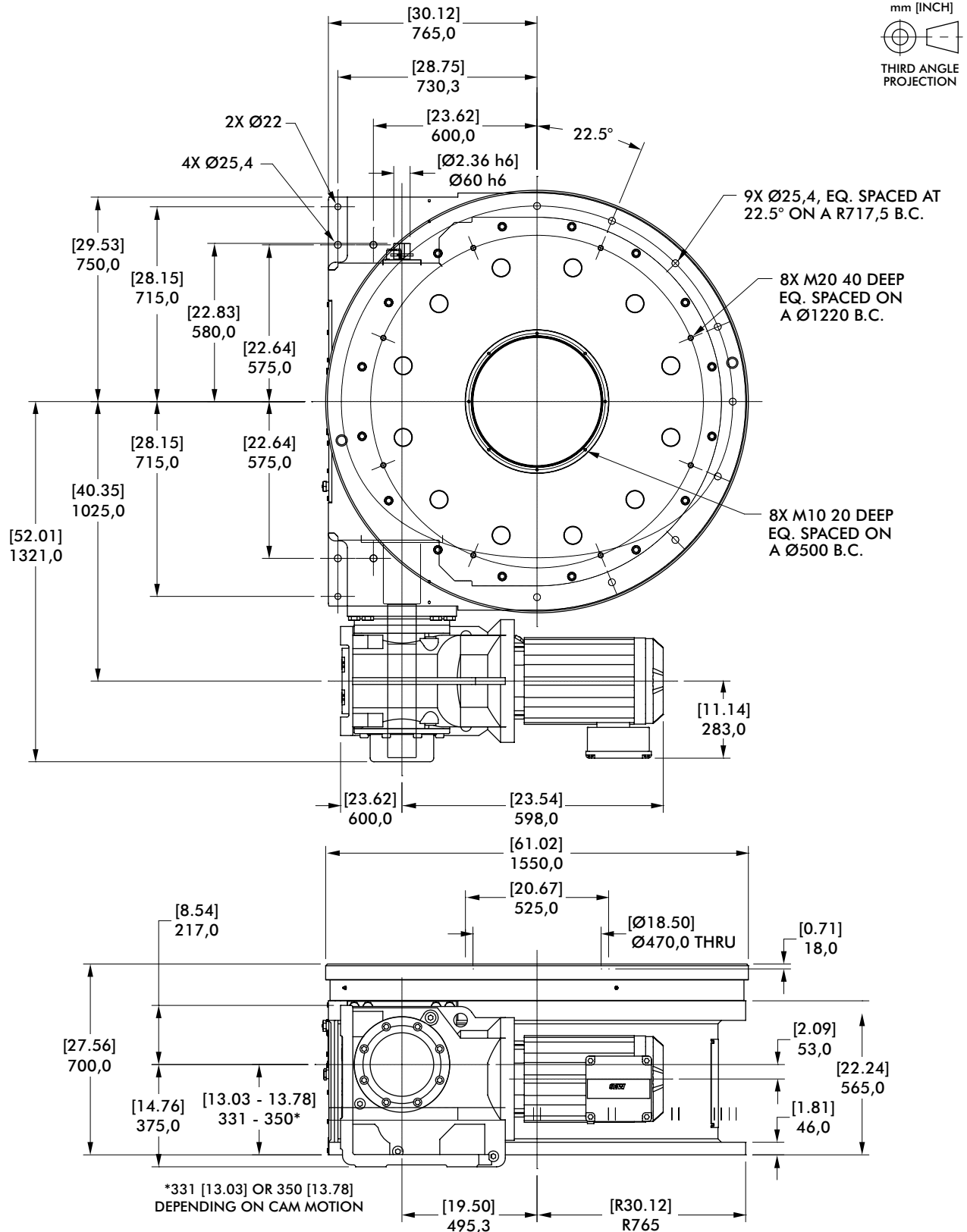

Maximum Inertia x 1000 kg-cm ² [lb-in ²] for standard package							
Stops	Motion Time [seconds]						
	1.23	1.65	2.17	2.50	2.75	3.37	3.74
2	[0] 0	[1926] 5636	[6208] 18167	[10388] 30399	[13740] 40209	[21944] 64217	[26735] 78237
3	[1811] 5300	[6814] 19940	[17561] 51390	[28054] 82097	[36466] 106714	[57057] 166971	[69084] 202167
4	[4396] 12864	[13172] 38546	[32028] 93727	[50439] 147605	[65198] 190795	[101324] 296514	[122426] 358267
6	[11290] 33039	[30132] 88178	[70615] 206647	[110143] 322322	[141829] 415048	[219391] 642025	[264696] 774605
8	[22185] 64922	[57289] 167650	[132712] 388368	[195668] 572602	[235249] 688432	1034294 [353436]	[436753] 1278112
12	146334 [50005]	366888 [125372]	[287302] 840760	1303461 [445415]	1674364 [572159]	2582270 [882406]	3038949 [1038461]
16	263112 [89910]	603493 [206224]	1039120 [355085]	1387320 [474071]	1667952 [569968]	2505914 [856314]	3038949 [1038461]
Reducer Ratio							
	40.19	54.07	70.95	81.98	89.89	110.18	122.48

Features

- KH127 Gear Reducer with Brake-motor
- Double Extended Camshaft (Input shaft)
- Center Thru Hole (Ø470 mm [Ø18.50 in])
- Cycle Cam and Limit Switch
- Right Hand Cam

Optional Accessories

- Left Hand Cam
- Relief in Dwell for Shot-Pin applications
- Dual Cam & limit Switch
- KH157 Gear Reducer with Brake-motor
- Stationary Center Post
- Visual Disk Dwell Indicator

Output Load Capacity (loads carried during index):

Radial	367423 N [82600 lbs]
Thrust/Axial	533786 N [120000 lbs]
Moment	328094 N-m [2904000 in-lbs]

Typical Application

Dial Diameter: 2997 mm to 5994 mm [118 in to 236 in]

Accuracy ±12 arcsec / ±0,043 mm [±.0017 in] at 762 mm [30in] Radius

Repeatability ±3 arcsec / ±0,010 mm [±.0004 in] at 762 mm [30in] Radius

PRECISION INDEXING SOLUTIONS

Table of Contents

INDEXERS

Servo Positioners



GTB Series
Globoidal (Roller Gear)
Servo Positioner.....IN-SRV-1

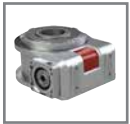

RSD Series
Rotary Servo Drives.....IN-SRV-39

Mechanical Indexers



RDM Series
Rotary Index Drive IN-MCH-2



RD Series
Roller Dial Index Drive..... IN-MCH-18



E Series
Heavy-Duty Index Drive IN-MCH-30



RA Series
Right Angle Index Drive IN-MCH-42



RGD/RGS Series
Roller Gear Index Drive IN-MCH-52



P Series
Parallel Shaft/Flange Drive.... IN-MCH-72



RNG Series
Ring Drive Dial Indexer.....IN-MCH-84

OVERLOAD CLUTCHES



Overload Clutches
Output Overload..... IN-CLU-1

CUSTOM CAMS



Custom Cams
Cam Design Solutions IN-CAM-1

CONVEYORS



Rite-Link Series
Thin-Profile.....IN-CNV-1



Precision Link Series
Table-TopIN-CNV-4



Precision Link Series
Heavy-Duty IN-CNV-16

PARTS HANDLERS



LPP Series
Linear Part Handlers IN-PRT-2



RPP Series
Rotary Part Handlers IN-PRT-8

RIGHT ANGLE INDEX DRIVES

Features | Table of Contents



Features:

CAMCO Right Angle Index Drives are ideal for dial applications or actuation-type applications such as driving a linkage or in-line conveyor.

Fixed center distance between input and output

Hardened, ground barrel cam

Compact design requiring minimum use of floor space.

Preloaded “rib-centered” design with modified-sine motion provides smooth acceleration and deceleration with precision positioning.

Universal mounting available on RA models.

Table of Contents

How to Order	3
400RA	5
512RA	7
662RA	9

RA SERIES

Right Angle Index Drive | How to Order

Indexer Ordering Procedure

1. Model
2. Input Shaft Configuration
 - Side 1
 - Side 2
 - Double Input – DI (Standard)
4. Indexer Mounting Position: 1-6
5. Indexer Housing Mounting Holes: Side 1-6 (more than one side can be selected)

Reducer Ordering Procedure

1. Model
2. Ratio: 5:1, 10:1, 15:1, 20:1, 25:1, 30:1, 40:1, 50:1, 60:1
3. Motor Adapter
4. Reducer Input Shaft Extension: Single Input (SE) or Double Input (DE)
5. Mounting (see diagram below)

Input Shaft Configuration (Top View)

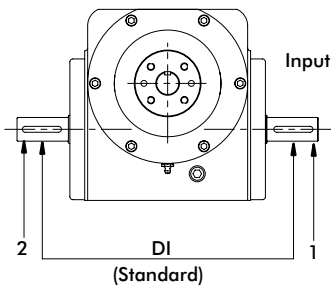

Input Shaft Rotation

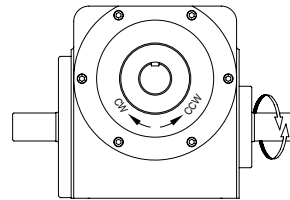

Relative Rotation for Right Hand Cam:

- CW Input Side 1 CCW Output
- CCW Input Side 2 CCW Output

NOTE: Input can be driven in either direction

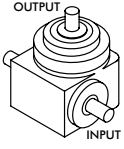
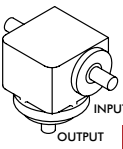
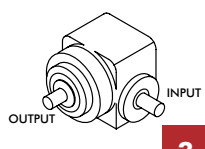
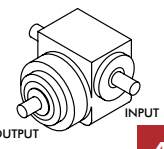
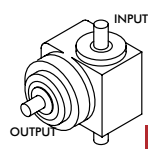
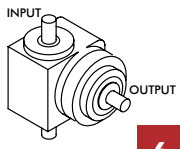
OVOI (output vertical, over input)	OVUI (output vertical, under input)	OHOI (output horizontal, over input)	OHUI (output horizontal, under input)	H-S1-UP (output horizontal, side 1 up)	H-S2-UP (output horizontal, side 2 up)
 1	 2	 3	 4	 5	 6

Gear Reducer Mounting Positions

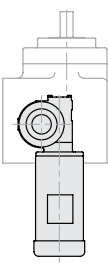
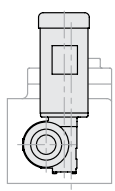
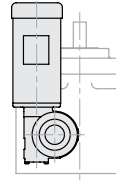
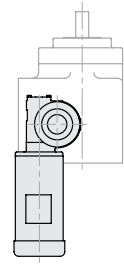
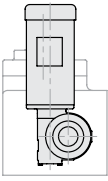
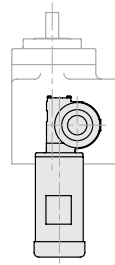
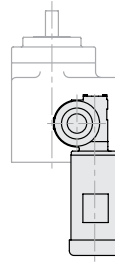
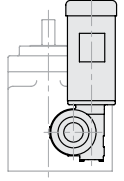
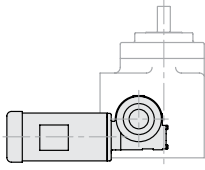
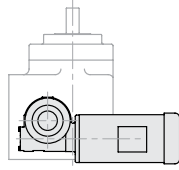
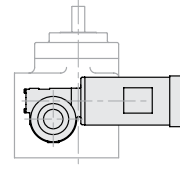
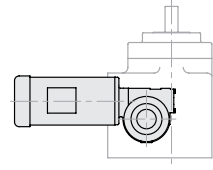
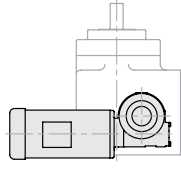
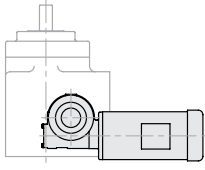
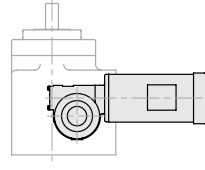
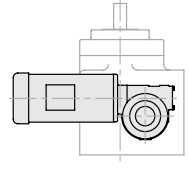
		Mounting "A"		Mounting "B"	
		RH	LH	RH	LH
SIDE 1	 A	 B	 C	 D	
	SIDE 2	 E	 F	 G	 H
		Mounting "C"		Mounting "D"	
		RH	LH	RH	LH
SIDE 1	 J	 K	 L	 M	
	SIDE 2	 N	 P	 R	 S

400RA SERIES

Right Angle Index Drive | Dimensions

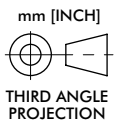
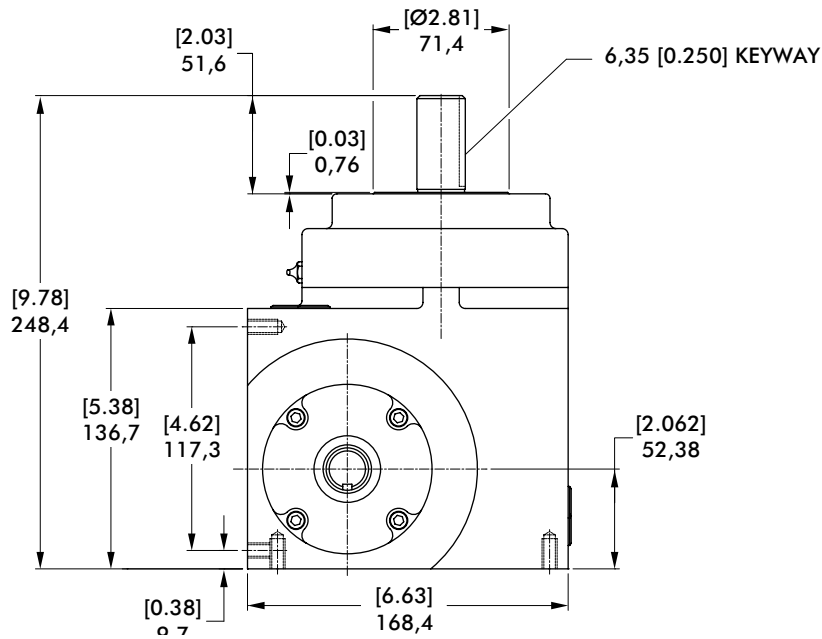
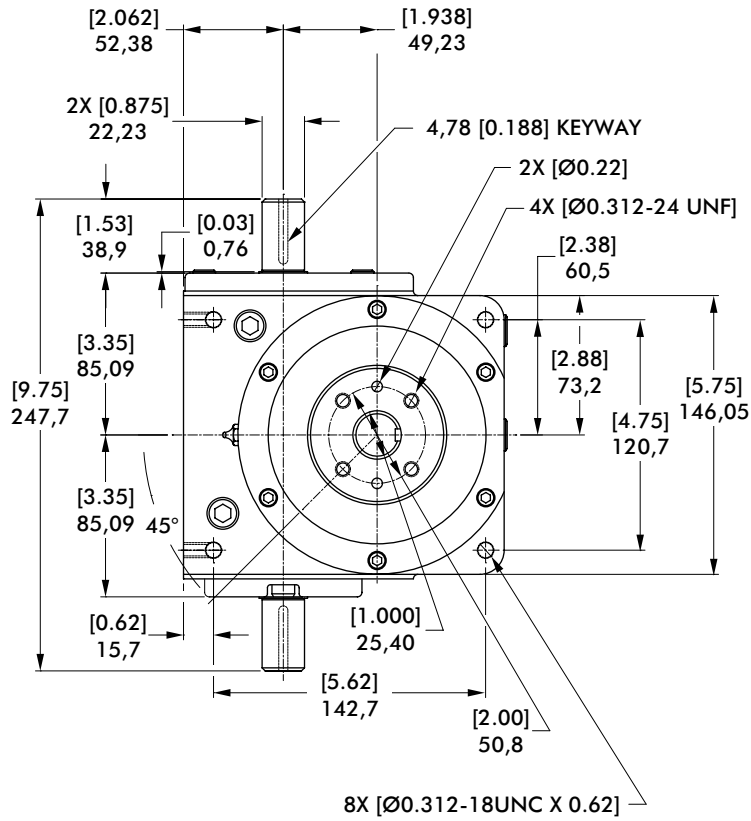

400RA Indexer Capacities					
Stops	Index Period	Motion	B ₁₀ Capacity at 50 RPM N-m [in-lb]	Internal Inertia kg-cm ² [lb-in ²]	Model
2	330	ms	67 [595]	44 [15]	400RA2H20-330
3	270	ms	180 [1591]	44 [15]	400RA3H24-270
4	270	ms	210 [1858]	44 [15]	400RA4H24-270
	180	ms	237 [2098]	44 [15]	400RA4H24-180
6	270	ms	193 [1711]	44 [15]	400RA6H24-270
	120	ms	229 [2024]	44 [15]	400RA6H24-120
8	270	ms	224 [1987]	44 [15]	400RA8H24-270
	120	ms	266 [2354]	44 [15]	400RA8H24-120
12	270	ms	146 [1290]	44 [15]	400RA12H20-270
	120	ms	177 [1568]	44 [15]	400RA12H20-120
16	270	ms	161 [1426]	44 [15]	400RA16H20-270 II
	180	ms	333 [2947]	44 [15]	400RA16H24-180 II
24	270	ms	185 [1640]	44 [15]	400RA24H20-270 II
	180	ms	214 [1894]	44 [15]	400RA24H20-180 II

Other Motions (stops and index periods) available. Contact your DESTACO sales representative for more information.

Features

- R180 Reducer (ratios from 15:1 to 60:1)
 - Double Extended Worm Shaft (Input)
 - Worm Shaft Handwheel
- Double Extended Camshaft (Input Shaft)
- 1/3 HP AC Drive Package with Inverter Duty Motor and IM-pAC AC Drive (up to 60 cpm)
- Cycle Cam and Limit Switch Mounted to Camshaft
- Right Hand Cam

Output Load Capacity (loads carried during index):

Radial	3603 N [810 lbs]
Thrust/Axial	6254 N [1406 lbs]
Moment	183 N-m [1620 in-lb]

Accuracy

±48 arcsec / ±0,178 mm [±.0007 in]
at 76,2 [3 in] Radius

Repeatability

±12 arcsec / ± 0,051 mm [±.0002 in]
at 76,2 [3 in] Radius

Optional Accessories

- 1/3 hp DC motor
- R225 Reducer (ratios from 10:1 to 60:1)
 - 1 hp DC Motor
 - 56C Motor Adapter and Coupling
- Varipak DC Motor Control (up to 30 cpm)
- Output Overload Clutch Models: 2.3F, 2.3FC, 2.3S, 2.3C, 2.3FC-SD, 2.3S-SD, 2.3C-SD
 - Available Settings (in-lb): 400, 600, 700, 850, 1000, 1300, 1800, 2000, 2300
- Dual Cycle Cam and Limit Switch
- Finished cover for ceiling mount or tooling plate mounting
- Left Hand Cam
- Relief in Dwell for shot-pin applications

512RA SERIES

Right Angle Index Drive | Dimensions

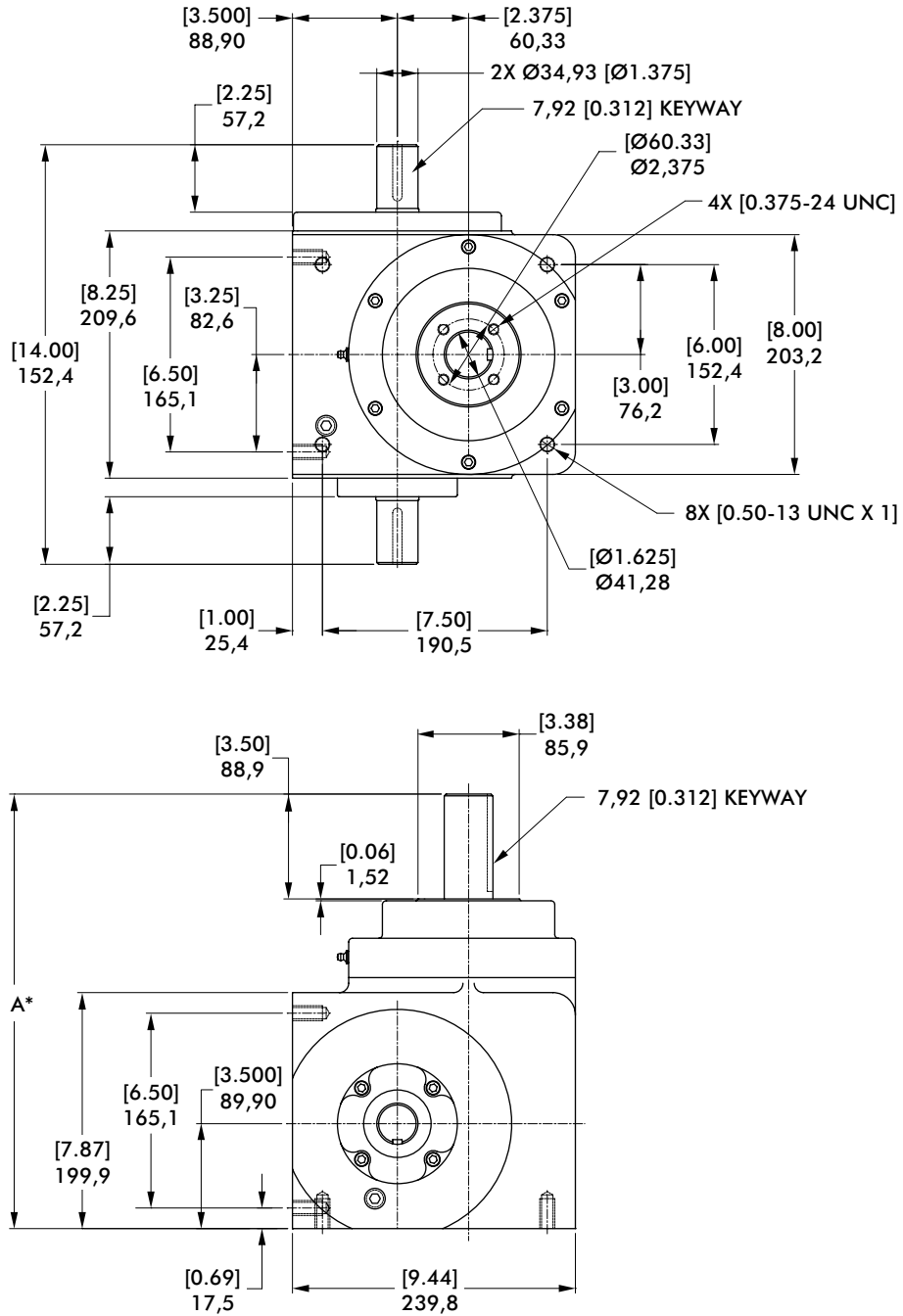

*See table on top of page 8 for dimensions

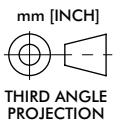

512RA Indexer Capacities						
Stops	Index Period	Motion	B ₁₀ Capacity at 50 RPM N-m [in-lb]	Internal Inertia kg-cm ² [lb-in ²]	Model	A
2	270	msc.33	233 [2061]	132 [45]	512RA2H32-270 MSC.33	379,2 [14.93]
3	270	ms	267 [2360]	132 [45]	512RA3H32-270	368,3 [14.50]
	180	msc.33	322 [2852]	132 [45]	512RA3H32-180 MSC 0.33	379,2 [14.93]
4	270	ms	306 [2710]	132 [45]	512RA4H32-270	368,3 [14.50]
	120	msc.33	412 [3648]	132 [45]	512RA4H32-120 MSC 0.33	379,2 [14.93]
6	270	ms	295 [2613]	132 [45]	512RA6H32-270	368,3 [14.50]
	120	ms	359 [3179]	132 [45]	512RA6H32-120	368,3 [14.50]
8	270	ms	358 [3172]	132 [45]	512RA8H32-270	368,3 [14.50]
	120	ms	430 [3802]	132 [45]	512RA8H32-120	368,3 [14.50]
12	270	ms	309 [2738]	132 [45]	512RA12H28-270	368,3 [14.50]
	120	ms	359 [3176]	132 [45]	512RA12H28-120	379,2 [14.93]

Other Motions (stops and index periods) available. Contact your DESTACO sales representative for more information.

Features

- R225 Reducer (ratios from 10:1 to 60:1)
– 56C Motor Adapter and Coupling
- Double Extended Camshaft (Input Shaft)
- 1 HP AC Drive Package with Inverter Duty Motor and Inverter Drive (up to 60 cpm)
- Cycle Cam and Limit Switch Mounted to Camshaft
- Right Hand Cam

Output Load Capacity (loads carried during index):

Radial	8834 N [1,986 lbs]
Thrust/Axial	10129 N [2,277 lbs]
Moment	785 N-m [6,951 in-lb]

Accuracy

±37 arcsec / ±0,028 mm [±.0011 in]
at 152,4 [6 in] Radius

Repeatability

±9 arcsec / ± 0,008 mm [±.0003 in]
at 152,4 [6 in] Radius

Optional Accessories

- 1 hp DC motor
- Varipak DC Motor Control (up to 30 cpm)
- Output Overload Clutch Models: 6.0F, 6.0FC, 6.0S and 6.0C, 6.0C-SD, 6.0FC-SD, 6.0S-SD
– Available Settings (in-lb): 670, 825, 1100, 1400, 1700, 2000, 2300, 2500, 3000, 3800, 4000, 5000, 6000
- Dual Cycle Cam and Limit Switch
- Finished cover for ceiling mount or tooling plate mounting
- Left Hand Cam
- Relief in Dwell for shot-pin applications

662RA SERIES

Right Angle Index Drive | Dimensions

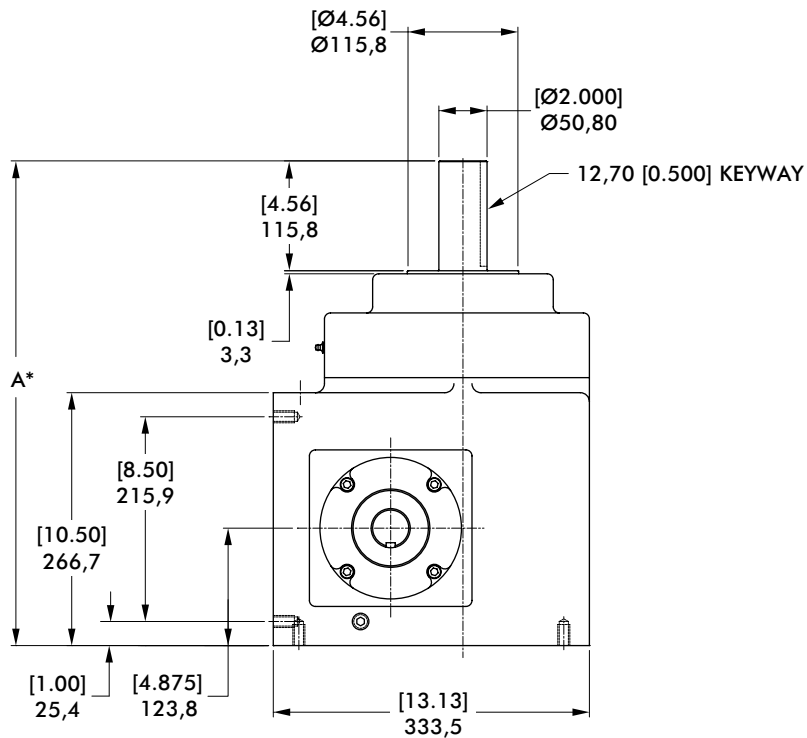
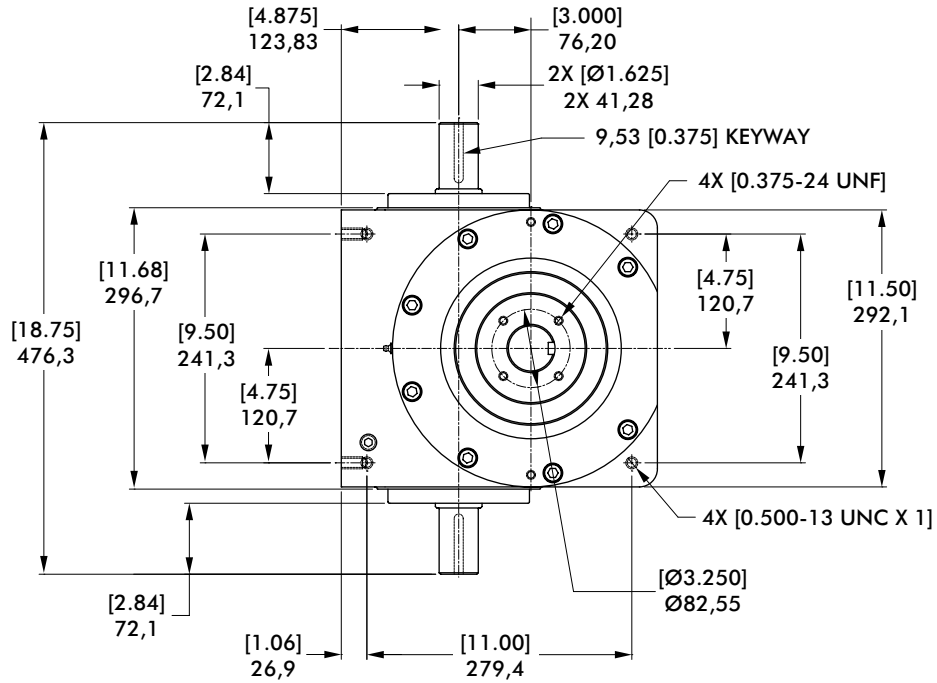

*See table on top of page 8 for dimensions

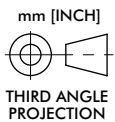

512RA Indexer Capacities						
Stops	Index Period	Motion	B ₀ Capacity at 50 RPM N-m [in-lb]	Internal Inertia kg-cm ² [lb-in ²]	Model	A
2	270	msc.33	738 [6534]	503 [172]	512RA2H32-270 MSC.33	379,2 [14.93]
3	270	ms	668 [5913]	495 [169]	512RA3H32-270	368,3 [14.50]
	180	msc.33	694 [6146]	495 [169]	512RA3H32-180 MSC 0.33	379,2 [14.93]
4	270	ms	780 [6903]	503 [172]	512RA4H32-270	368,3 [14.50]
	120	msc.33	876 [7751]	503 [172]	512RA4H32-120 MSC 0.33	379,2 [14.93]
6	270	ms	648 [5734]	495 [169]	512RA6H32-270	368,3 [14.50]
	120	ms	853 [7551]	495 [169]	512RA6H32-120	368,3 [14.50]
8	270	ms	812 [7187]	503 [172]	512RA8H32-270	368,3 [14.50]
	120	ms	1015 [8987]	503 [172]	512RA8H32-120	368,3 [14.50]
12	270	ms	509 [4504]	483 [165]	512RA12H28-270	368,3 [14.50]
	120	ms	625 [5536]	483 [165]	512RA12H28-120	379,2 [14.93]

Other Motions (stops and index periods) available. Contact your DESTACO sales representative for more information.

Features

- 7300C Reducer (ratios from 5:1 to 60:1)
 - Motor Adapter and Coupling
- Double Extended Camshaft (Input Shaft)
- 1 or 2 HP AC Drive Package with Inverter Duty Motor and Inverter Drive (up to 60 cpm)
- Varipak DC Motor Control (up to 30 cpm)
- Cycle Cam and Limit Switch Mounted to Camshaft
- Right Hand Cam

Output Load Capacity (loads carried during index):

Radial	12642 N [2842 lbs]
Thrust/Axial	23304 N [5239 lbs]
Moment	334 N-m [2959 in-lb]

Accuracy

±36 arcsec / ±0,025 mm [±.001 in]
at 152,4 [6 in] Radius

Repeatability

±9 arcsec / ± 0,008 mm [±.0003 in]
at 152,4 [6 in] Radius

Optional Accessories

- 1 hp DC motor
- 7350C Reducer (ratios from 5:1 to 60:1)
 - Motor Adapter and Coupling
- 2 hp DC Motor with Varipak DC Motor Control (up to 30 cpm)
- Output Overload Clutch Models: 11F, 11FC, 11FC-SD
 - Available Settings (in-lb): 2300, 4000, 6000, 8500, 11,000
- Dual Cycle Cam and Limit Switch
- Finished cover for ceiling mount or tooling plate mounting
- Left Hand Cam
- Relief in Dwell for shot-pin applications

PRECISION INDEXING SOLUTIONS

Table of Contents

INDEXERS

Servo Positioners



GTB Series
Globoidal (Roller Gear)
Servo Positioner.....IN-SRV-1



RSD Series
Rotary Servo Drives.....IN-SRV-39

Mechanical Indexers



RDM Series
Rotary Index Drive IN-MCH-2



RD Series
Roller Dial Index Drive..... IN-MCH-18



E Series
Heavy-Duty Index Drive IN-MCH-30



RA Series
Right Angle Index Drive IN-MCH-42



RGD/RGS Series
Roller Gear Index Drive IN-MCH-52



P Series
Parallel Shaft/Flange Drive.... IN-MCH-72



RNG Series
Ring Drive Dial Indexer.....IN-MCH-84

OVERLOAD CLUTCHES



Overload Clutches
Output Overload..... IN-CLU-1

CUSTOM CAMS



Custom Cams
Cam Design Solutions IN-CAM-1

CONVEYORS



Rite-Link Series
Thin-Profile.....IN-CNV-1



Precision Link Series
Table-TopIN-CNV-4



Precision Link Series
Heavy-Duty IN-CNV-16

PARTS HANDLERS



LPP Series
Linear Part Handlers IN-PRT-2



RPP Series
Rotary Part Handlers IN-PRT-8

ROLLER GEAR INDEX DRIVE

Precision Indexing | Table of Contents



Features:

The **CAMCO Roller Gear Index Drives** are robust, versatile units suitable for a wide variety of applications.

Available with a flange (RGD) or shaft (RGS) output

All six surfaces are machined for universal mounting

Optional center thru-hole in flange version facilitates passage of electrical wiring, pneumatic lines or mechanical linkages

Short camshaft motion periods, due to oversized cam design, are well suited for continuous running applications or for special motion requirements such as oscillating motions

Table of Contents

How to Order	3
40RGD/40RGS	5
50RGD/50RGS	7
70RGD/70RGS	9
80RGD/80RGS	11
110RGD/110RGS	13
350RGD/350RGS	15
500RGD/500RGS	17
600RGD/600RGS	19

RGD/RGS SERIES

Roller Gear Index Drive | How To Order

Indexer Ordering Procedure

1. Model
 2. Input Shaft Configuration
 - Side 1
 - Side 2
 - Double Input – DI (Standard)
 3. Cam Lead (Helix)
 - Right Hand (Standard)
 - Left Hand
- NOTE: Input may rotate in either direction to achieve desired direction of output rotation.
4. Indexer Mounting Position: 1-6
 5. Indexer Housing Mounting Holes: Side 1-6 (more than one side can be selected)

Reducer Ordering Procedure

1. Model
2. Ratio
 - 10:1, 15:1, 20:1, 25:1, 30:1, 40:1, 50:1, 60:1
3. Motor Adapter
4. Reducer Input Shaft Extension
 - Single Input (SE) or Double Input (DE)
5. Mounting
 - Mounting Position A, B, C, or D
 - Mounted on Indexer Side 1 or Side 2
6. Input Shaft Orientation
 - Left or Right (See Diagram Below)

Input Shaft Configuration (Top View)

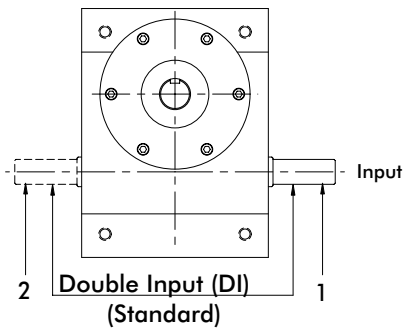

Input Shaft Rotation

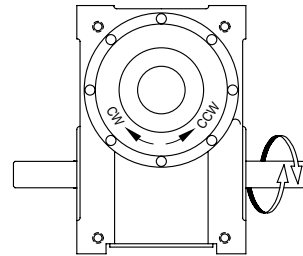

Relative Rotation for Right Hand Cam:

- CW Input Side 1 CCW Output
- CCW Input Side 2 CCW Output

NOTE: Input can be driven in either direction

Indexer Housing Mounting Holes

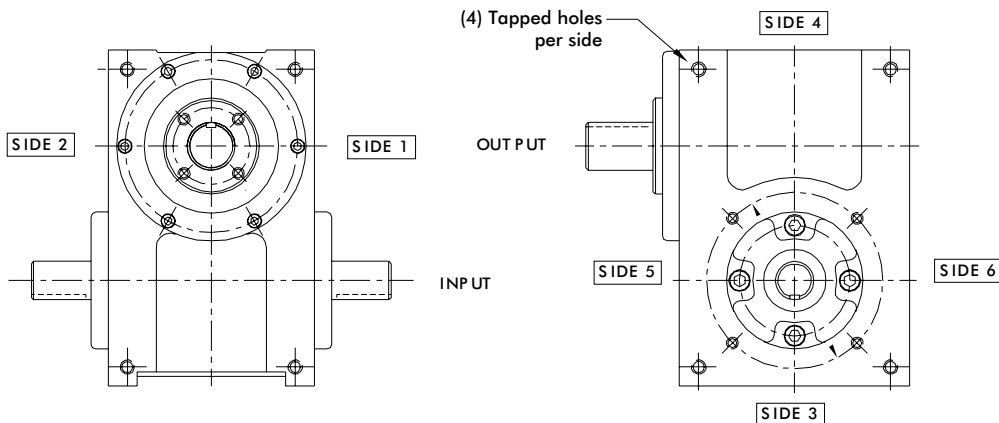

RGD/RGS SERIES

Roller Gear Index Drive | Indexer Mounting Position

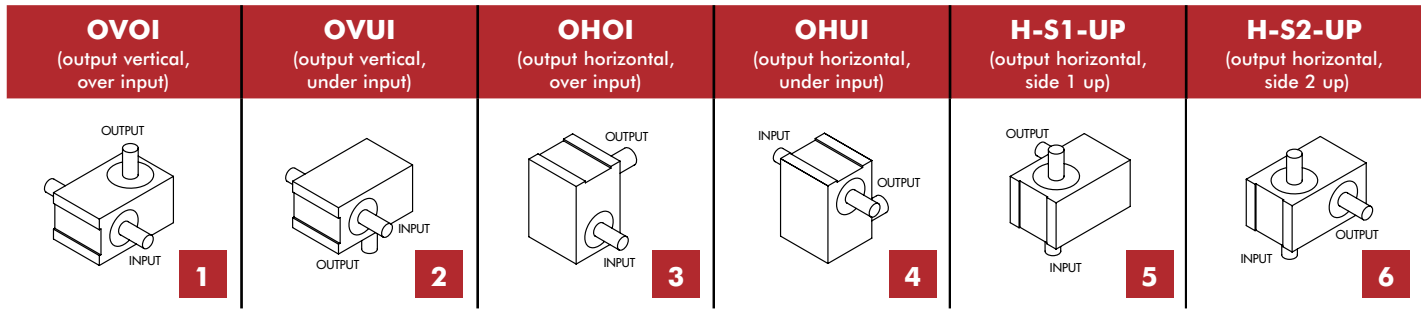

Gear Reducer Mounting Positions (Figure 4)

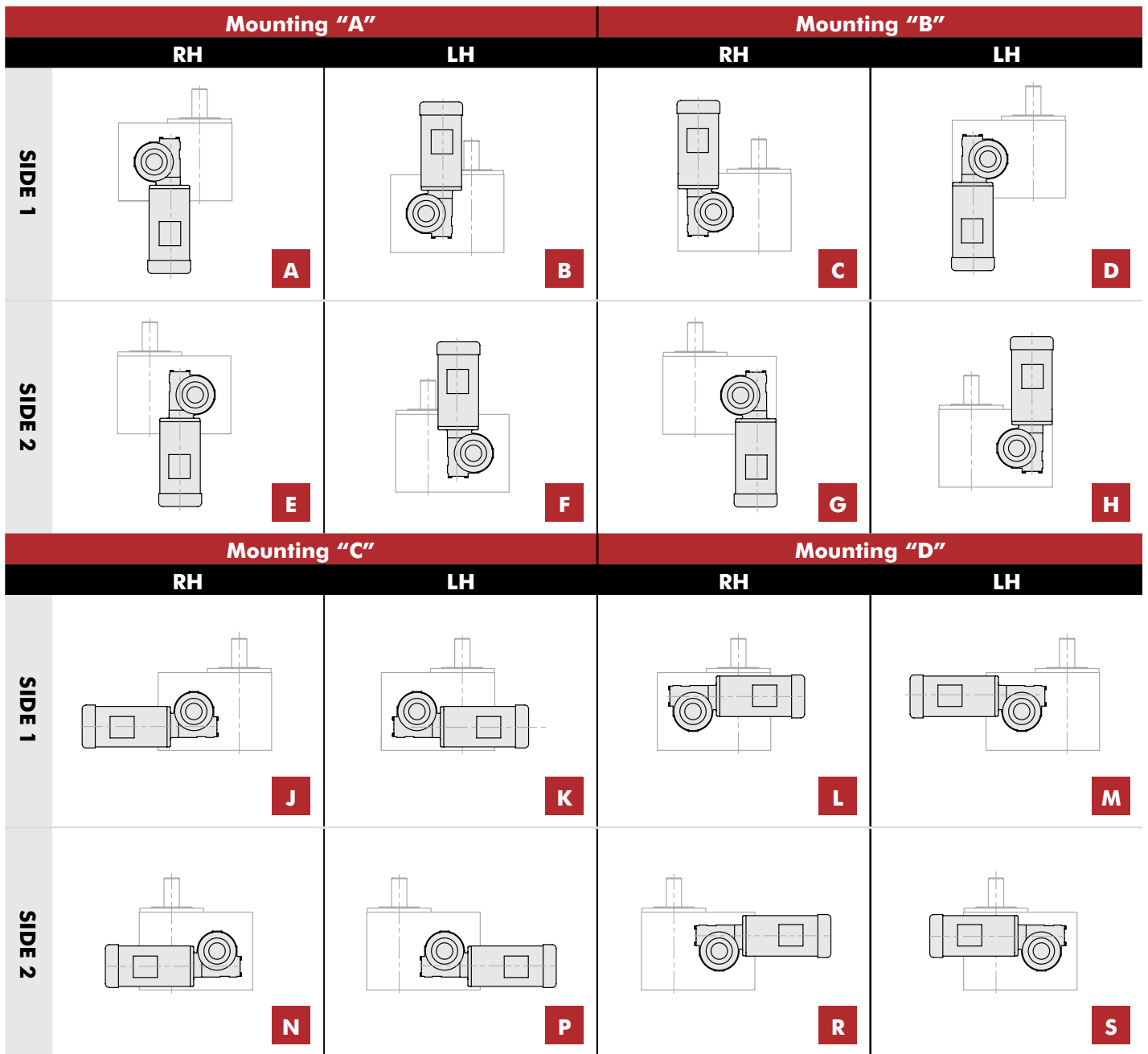

40RGD/40RGS SERIES

Roller Gear Index Drive | Dimensions

40RGD

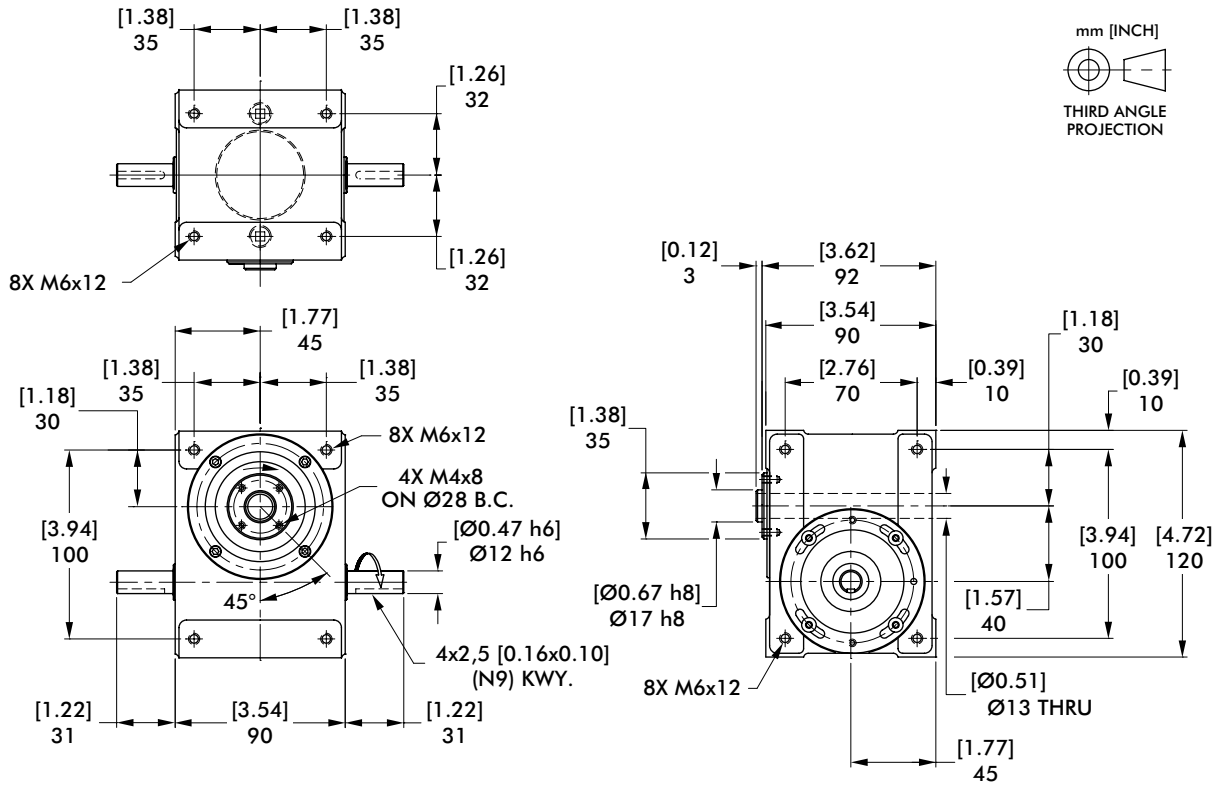

40RGS

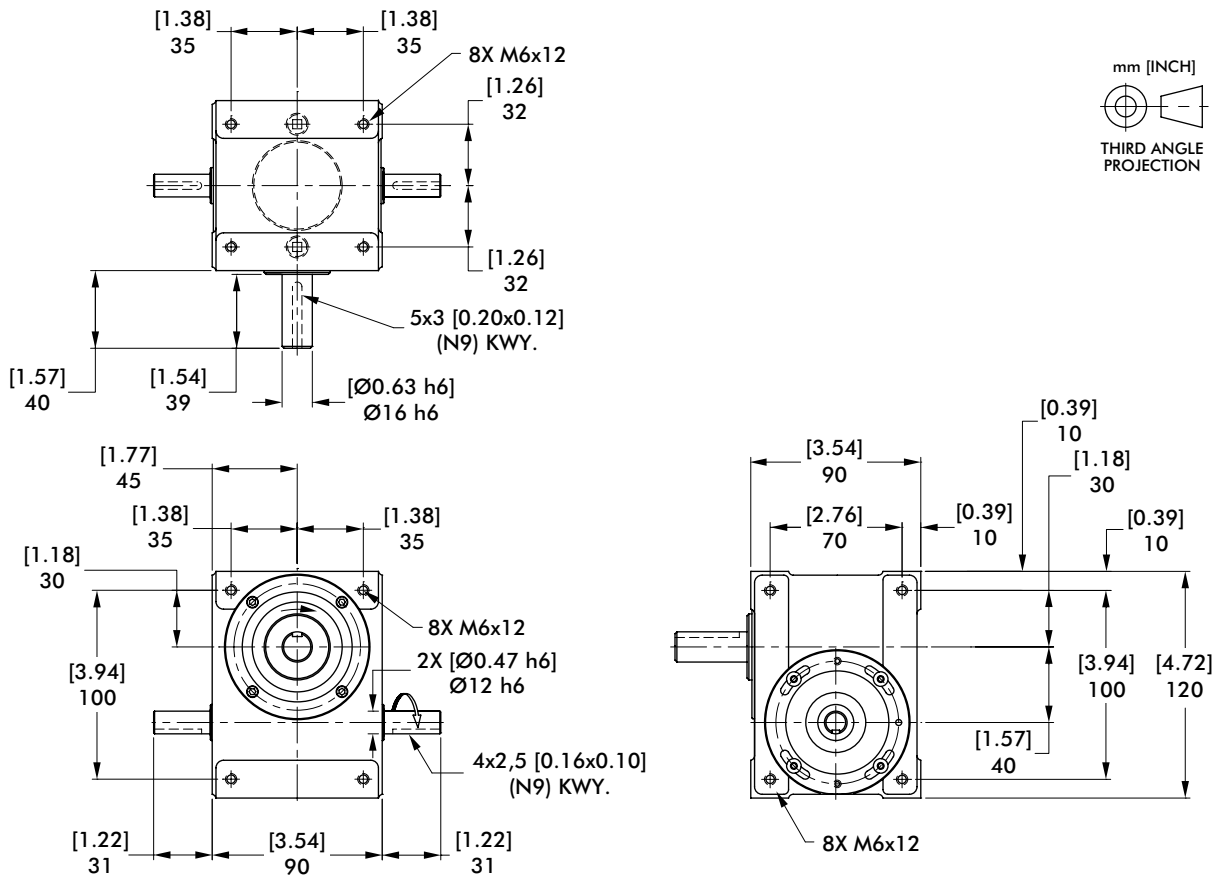

40RGD/40RGS SERIES

Roller Gear Index Drive | Features | Optional Accessories | Technical Information

40RGD/40RGS Indexer Capacities						
Stops	Index Period	Motion	B ₀ Capacity at 50 RPM N-m [in-lb]	RGD Internal Inertia kg-cm ² [lb-in ²]	RGS Internal Inertia kg-cm ² [lb-in ²]	Model
2	270	ms	17 [150]	0,9 [0.3]	1,2 [0.4]	40RG(D/S)2H12-270
3	270	ms	21 [187]	0,9 [0.3]	1,2 [0.4]	40RG(D/S)3H12-270
4	270	ms	24 [214]	1,2 [0.4]	1,2 [0.4]	40RG(D/S)4H12-270
	180	ms	25 [225]	1,2 [0.4]	1,2 [0.4]	40RG(D/S)4H12-180
6	270	ms	22 [193]	0,9 [0.3]	1,2 [0.4]	40RG(D/S)6H12-270
	90	ms	24 [216]	0,9 [0.3]	1,2 [0.4]	40RG(D/S)6H12-90
8	270	ms	24 [216]	1,2 [0.4]	1,2 [0.4]	40RG(D/S)8H12-270
	90	ms	28 [249]	1,2 [0.4]	1,2 [0.4]	40RG(D/S)8H12-90
12	270	ms	14 [124]	0,9 [0.3]	1,2 [0.4]	40RG(D/S)12H9-270
	90	ms	16 [139]	0,9 [0.3]	1,2 [0.4]	40RG(D/S)12H9-90
16	270	ms	29 [254]	1,2 [0.4]	1,2 [0.4]	40RG(D/S)16H12-270 II
	120	ms	35 [312]	1,2 [0.4]	1,2 [0.4]	40RG(D/S)16H12-120 II
24	180	ms	20 [173]	0,9 [0.3]	1,2 [0.4]	40RG(D/S)24H9-180 II
	120	ms	37 [326]	0,9 [0.3]	1,2 [0.4]	40RG(D/S)24H12-120 III

Other Motions (stops and index periods) available. Contact your DESTACO sales representative for more information.

Features

- Fully Metric
- Universal Mounting: mounting holes on any of 6 sides
- Center Through Hole (Ø13 mm [Ø.50 in]) in RGD model.
- Right Hand Cam

Optional Accessories

- STM RMI28 Gear Reducer (ratios from 7:1 to 100:1) with
 - IEC56B14 Motor Adapter
 - 1/12 HP AC Motor and Inverter Drive (up to 60 cpm)
- Single or Dual Cycle Cam and Limit Switch
- Left Hand Cam
- Relief in Dwell for shot-pin applications

Output Load Capacity (loads carried during index):

	RGD	RGS
Radial	4924 N [1107 lbs]	916 N [206 lbs]
Thrust/Axial	3519 N [791 lbs]	2189 N [492 lbs]
Moment	86 N-m [762 in-lb]	46 N-m [405 in-lb]

Accuracy ±90 arcsec / ±0,033 mm [±.0013 in] at 76,2 mm [3 in] Radius

Repeatability ±22 arcsec / ±0,008 mm [±.0003 in] at 76,2 mm [3 in] Radius

50RGD/50RGS SERIES

Roller Gear Index Drive | Dimensions

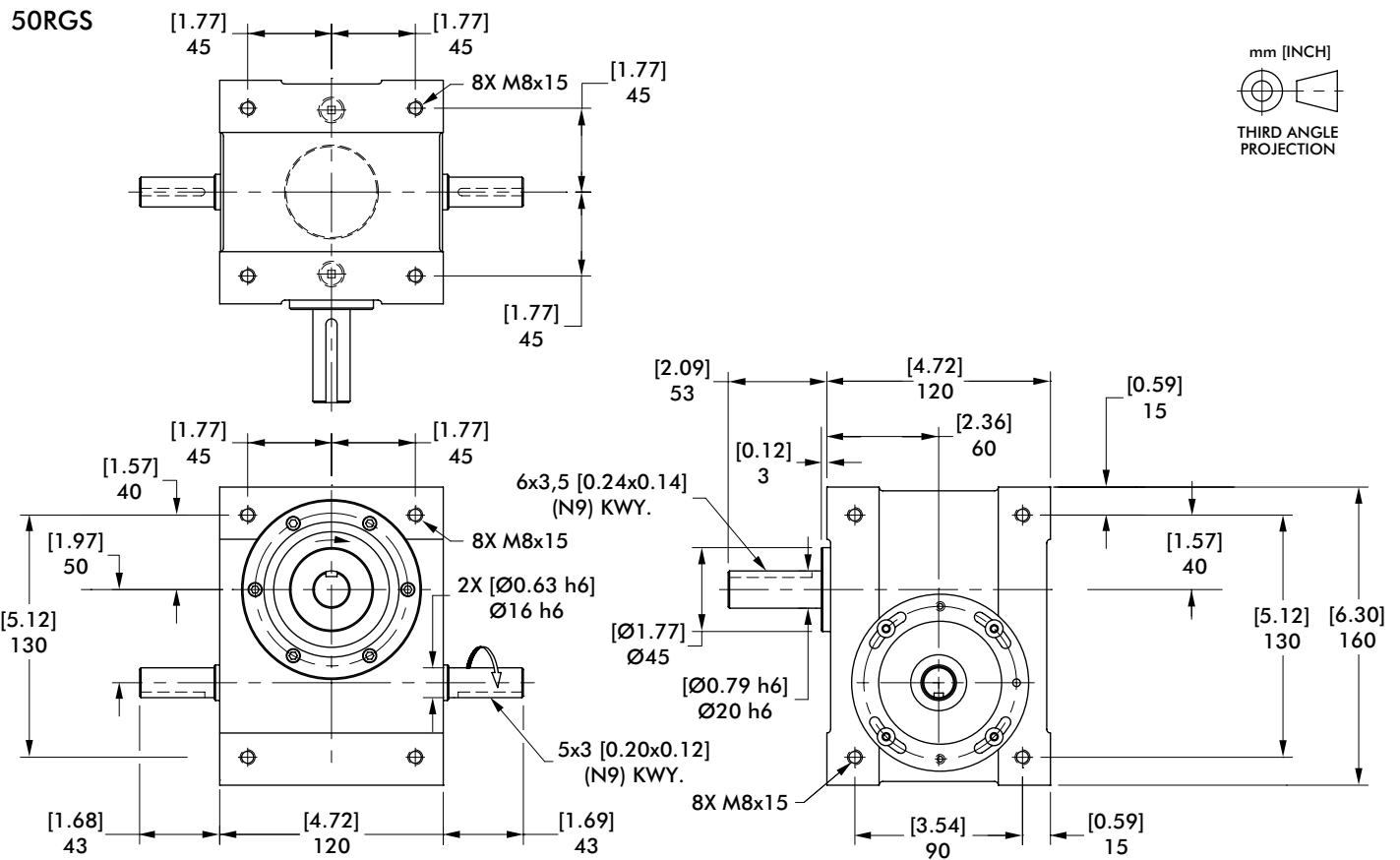
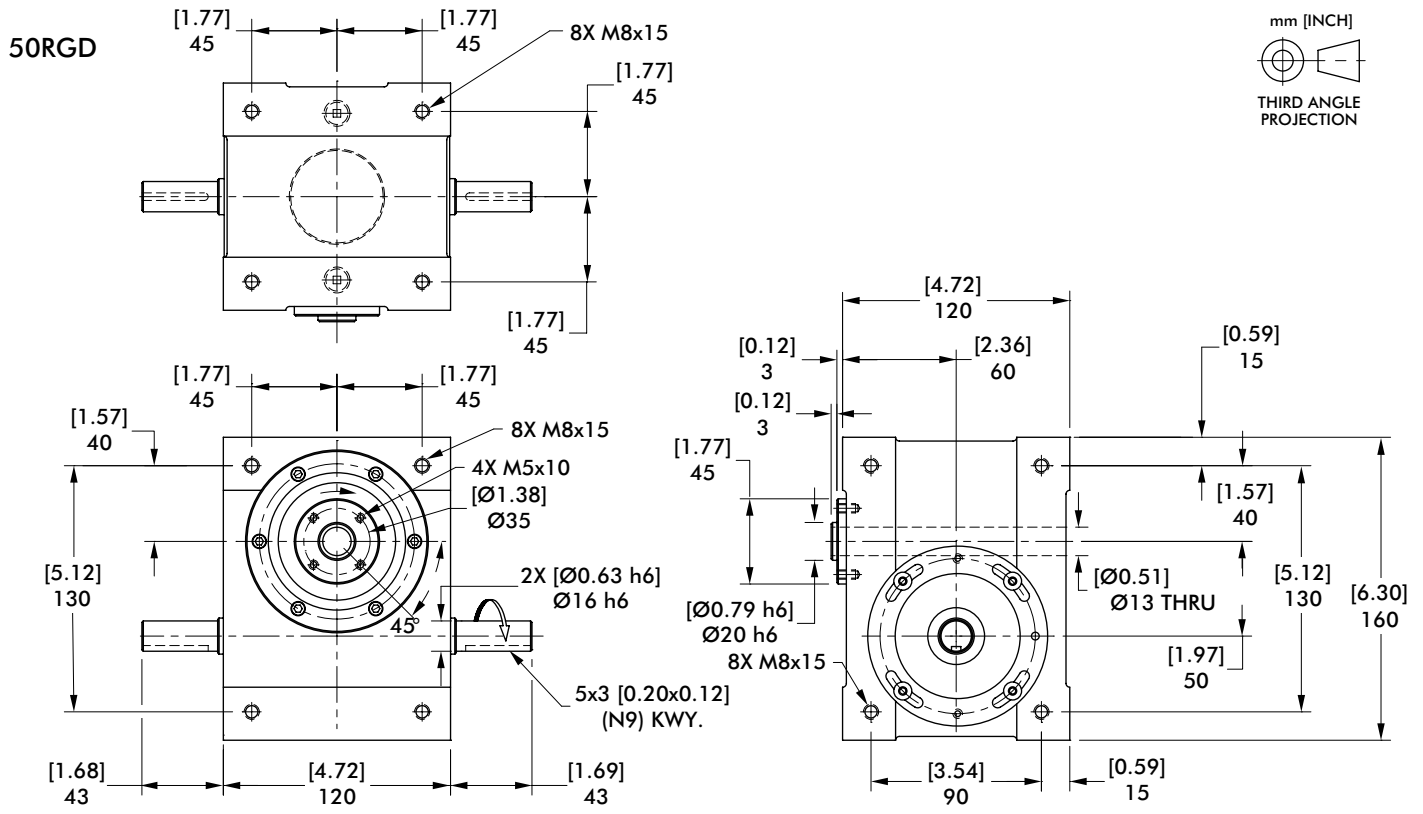

50RGD/50RGS SERIES

Roller Gear Index Drive | Features | Optional Accessories | Technical Information

40RGD/40RGS Indexer Capacities						
Stops	Index Period	Motion	B ₀ Capacity at 50 RPM N-m [in-lb]	RGD Internal Inertia kg-cm ² [lb-in ²]	RGS Internal Inertia kg-cm ² [lb-in ²]	Model
2	270	msc.50	70 [621]	4,1 [1.4]	4,7 [1.6]	50RG(D/S)2H18-270
3	270	ms	32 [287]	3,8 [1.3]	4,4 [1.5]	50RG(D/S)3H14-270
	180	ms	34 [300]	3,8 [1.3]	4,4 [1.5]	50RG(D/S)3H14-180
4	270	ms	37 [326]	4,1 [1.4]	4,4 [1.5]	50RG(D/S)4H14-270
	180	ms	40 [351]	4,1 [1.4]	4,4 [1.5]	50RG(D/S)4H14-180
6	270	ms	68 [606]	4,1 [1.4]	4,7 [1.6]	50RG(D/S)6H18-270
	90	ms	83 [734]	4,1 [1.4]	4,7 [1.6]	50RG(D/S)6H18-90
8	270	ms	38 [336]	4,1 [1.4]	4,4 [1.5]	50RG(D/S)8H14-270
	90	ms	46 [403]	4,1 [1.4]	4,4 [1.5]	50RG(D/S)8H14-90
12	270	ms	31 [275]	4,1 [1.4]	4,4 [1.5]	50RG(D/S)12H12-270
	90	ms	37 [329]	4,1 [1.4]	4,4 [1.5]	50RG(D/S)12H12-90
16	180	ms	51 [447]	4,1 [1.4]	4,4 [1.5]	50RG(D/S)16H14-180 II
24	180	ms	42 [374]	4,1 [1.4]	4,4 [1.5]	50RG(D/S)24H12-180 II
	120	ms	46 [409]	4,1 [1.4]	4,4 [1.5]	50RG(D/S)24H12-120 II

Other Motions (stops and index periods) available. Contact your DESTACO sales representative for more information.

Features

- Fully Metric
- Universal Mounting: mounting holes on any of 6 sides
- Center Through Hole (Ø15 mm [Ø.59 in]) in RGD model.
- Right Hand Cam

Optional Accessories

- R180 Reducer (Ratios from 15:1 to 60:1)
 - Double Extended Worm Shaft (Input)
 - Worm Shaft Handwheel
- 1/3 HP AC Drive Package with Inverter Duty Motor and IM-pAC AC Drive (up to 60 cpm)
- Cycle Cam and Limit Switch Mounted to Camshaft
- Right Hand Cam
- Universal Mounting Capability

Output Load Capacity (loads carried during index):

	RGD	RGS
Radial	7896 N [1775 lbs]	1686 N [379 lbs]
Thrust/Axial	4115 N [925 lbs]	2424 N [545 lbs]
Moment	178 N-m [1572 in-lb]	89 N-m [791 in-lb]

Accuracy ±73 arcsec / ±0,028 mm [±.0011 in] at 76,2 mm [3 in] Radius

Repeatability ±18 arcsec / ±0,008 mm [±.0003 in] at 76,2 mm [3 in] Radius

70RGD/70RGS SERIES

Roller Gear Index Drive | Dimensions

70RGD

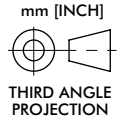
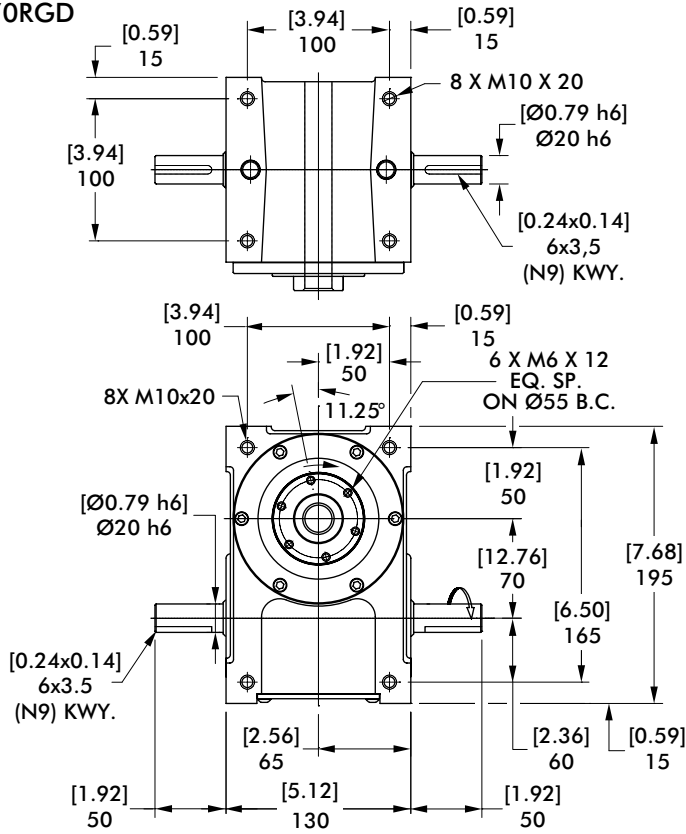

70RGS

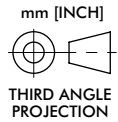
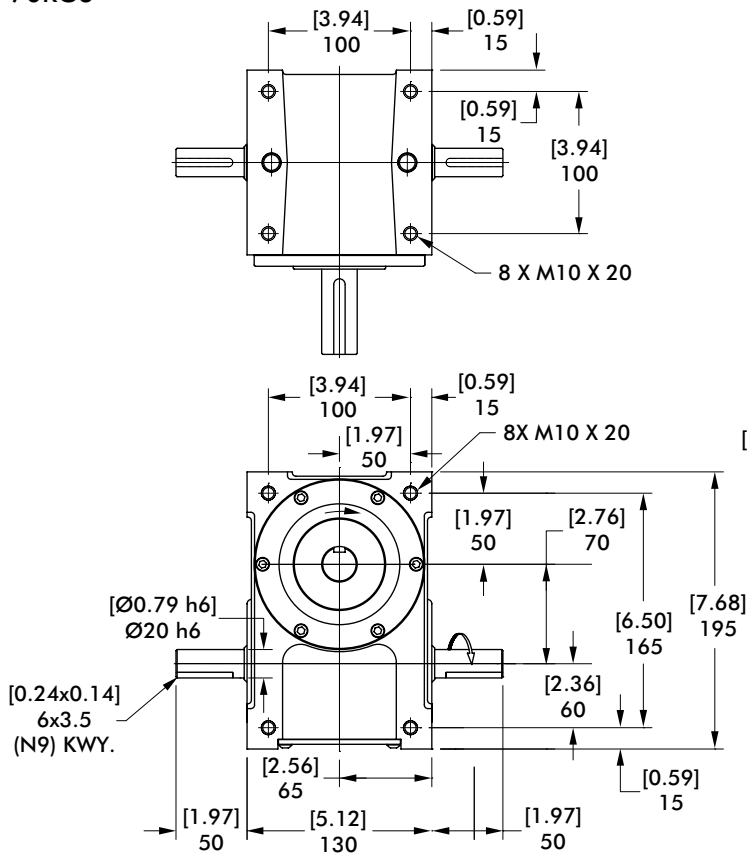

70RGD/70RGS SERIES

Roller Gear Index Drive | Features | Optional Accessories | Technical Information

40RGD/40RGS Indexer Capacities						
Stops	Index Period	Motion	B ₀ Capacity at 50 RPM N-m [in-lb]	RGD Internal Inertia kg-cm ² [lb-in ²]	RGS Internal Inertia kg-cm ² [lb-in ²]	Model
2	270	ms	66 [585]	20,5 [7]	23,4 [8]	70RG(D/S)2H20-270
	180	ms	63 [562]	20,5 [7]	23,4 [8]	70RG(D/S)2H18-180
3	270	ms	81 [720]	20,5 [7]	23,4 [8]	70RG(D/S)3H20-270
	180	ms	85 [753]	20,5 [7]	23,4 [8]	70RG(D/S)3H20-180
4	270	ms	93 [821]	26,3 [9]	29,3 [10]	70RG(D/S)4H20-270
	120	msc,33	125 [1107]	29,3 [10]	29,3 [10]	70RG(D/S)4H18-120
6	270	ms	159 [1406]	26,3 [9]	29,3 [10]	70RG(D/S)6H24-270
	90	msc,33	238 [2110]	26,3 [9]	29,3 [10]	70RG(D/S)6H24-90
8	270	ms	96 [853]	26,3 [9]	29,3 [10]	70RG(D/S)8H20-270
	90	ms	120 [1063]	26,3 [9]	29,3 [10]	70RG(D/S)8H20-90
12	270	ms	53 [470]	29,3 [10]	29,3 [10]	70RG(D/S)12H14-270
	90	ms	66 [584]	29,3 [10]	29,3 [10]	70RG(D/S)12H14-90
24	180	ms	72 [635]	29,3 [10]	29,3 [10]	70RG(D/S)24H14-180 II

Other Motions (stops and index periods) available. Contact your DESTACO sales representative for more information.

Features

- Fully Metric
- Universal Mounting: mounting holes on any of 6 sides
- Center Through Hole (Ø19 mm [Ø.75 in]) in RGD model.
- Right Hand Cam

Output Load Capacity (loads carried during index):

	RGD	RGS
Radial	12602 N [2833 lbs]	2491 N [560 lbs]
Thrust/Axial	9893 N [2224 lbs]	3567 N [802 lbs]
Moment	410 N-m [3626 in-lb]	175 N-m [1545 in-lb]

Accuracy ±50 arcsec / ±0,020 mm [±.0008 in] at 76,2 mm [3 in] Radius

Repeatability ±13 arcsec / ±0,005 mm [±.0002 in] at 76,2 mm [3 in] Radius

Optional Accessories

- R180 Reducer (Ratios from 5:1 to 60:1)
- 1/3 HP AC Drive Package with Inverter Duty Motor and Inverter Drive (up to 60 cpm)
- 1/3 HP DC Motor with Varipak DC Motor Control (up to 30 cpm)
- Single or Dual Cycle Cam and Limit Switch
- Left Hand Cam
- Relief in Dwell for shot-pin applications

80RGD/80RGS SERIES

Roller Gear Index Drive | Features | Optional Accessories | Technical Information

40RGD/40RGS Indexer Capacities						
Stops	Index Period	Motion	B ₀ Capacity at 50 RPM N-m [in-lb]	RGD Internal Inertia kg-cm ² [lb-in ²]	RGS Internal Inertia kg-cm ² [lb-in ²]	Model
2	330	ms	129 [1144]	46,8 [16]	49,7 [17]	80RG(D/S)2H24-330
	270	msc.33	157 [1388]	46,8 [16]	49,7 [17]	80RG(D/S)2H24-270
3	270	ms	161 [1422]	46,8 [16]	49,7 [17]	80RG(D/S)3H24-270
	180	ms	171 [1513]	46,8 [16]	49,7 [17]	80RG(D/S)3H24-180
4	270	ms	188 [1663]	61,5 [21]	61,5 [21]	80RG(D/S)4H24-270
	180	msc.33	269 [2377]	61,5 [21]	61,5 [21]	80RG(D/S)4H24-180
6	270	ms	172 [1524]	52,7 [18]	55,6 [19]	80RG(D/S)6H28-270
	90	msc.50	262 [2323]	52,7 [18]	55,6 [19]	80RG(D/S)6H28-90
8	270	ms	196 [1733]	61,5 [21]	61,5 [21]	80RG(D/S)8H24-270
	90	msc.33	332 [2937]	61,5 [21]	61,5 [21]	80RG(D/S)8H24-90
12	270	ms	114 [1011]	58,5 [20]	58,5 [20]	80RG(D/S)12H18-270
	90	msc.60	195 [1725]	58,5 [20]	58,5 [20]	80RG(D/S)12H18-90

Other Motions (stops and index periods) available. Contact your DESTACO sales representative for more information.

Features

- Fully Metric
- Universal Mounting: mounting holes on any of 6 sides
- Center Through Hole (Ø26 mm [Ø1.02 in]) in RGD model.
- Right Hand Cam

Output Load Capacity (loads carried during index):

	RGD	RGS
Radial	21,307 N [4790 lbs]	5289 N [1189 lbs]
Thrust/Axial	15435 N [3470 lbs]	5542 N [1246 lbs]
Moment	852 N-m [7544 in-lb]	302 N-m [2669 in-lb]

Accuracy ±48 arcsec / ±0,018 mm [±.0007 in] at 76,2 mm [3 in] Radius

Repeatability ±12 arcsec / ±0,005 mm [±.0002 in] at 76,2 mm [3 in] Radius

Optional Accessories

- R180 Reducer (Ratios from 5:1 to 60:1)
- 1/3 HP AC Drive Package with Inverter Duty Motor and Inverter Drive (up to 60 cpm)
- 1/3 HP DC Motor with Varipak DC Motor Control (up to 30 cpm)
- Single or Dual Cycle Cam and Limit Switch
- Left Hand Cam
- Relief in Dwell for shot-pin applications

110RGD/110RGS SERIES

Roller Gear Index Drive | Dimensions

110RGD

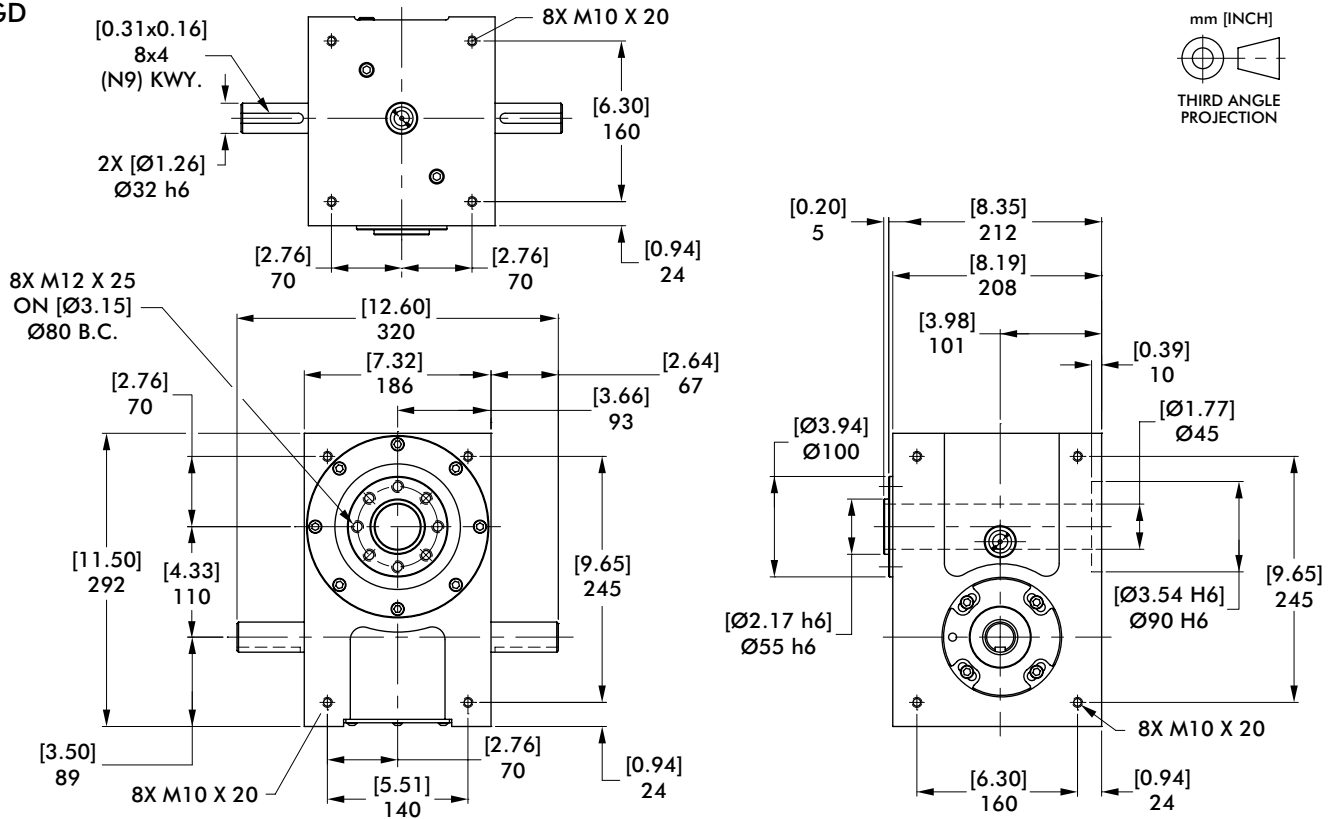

110RGS

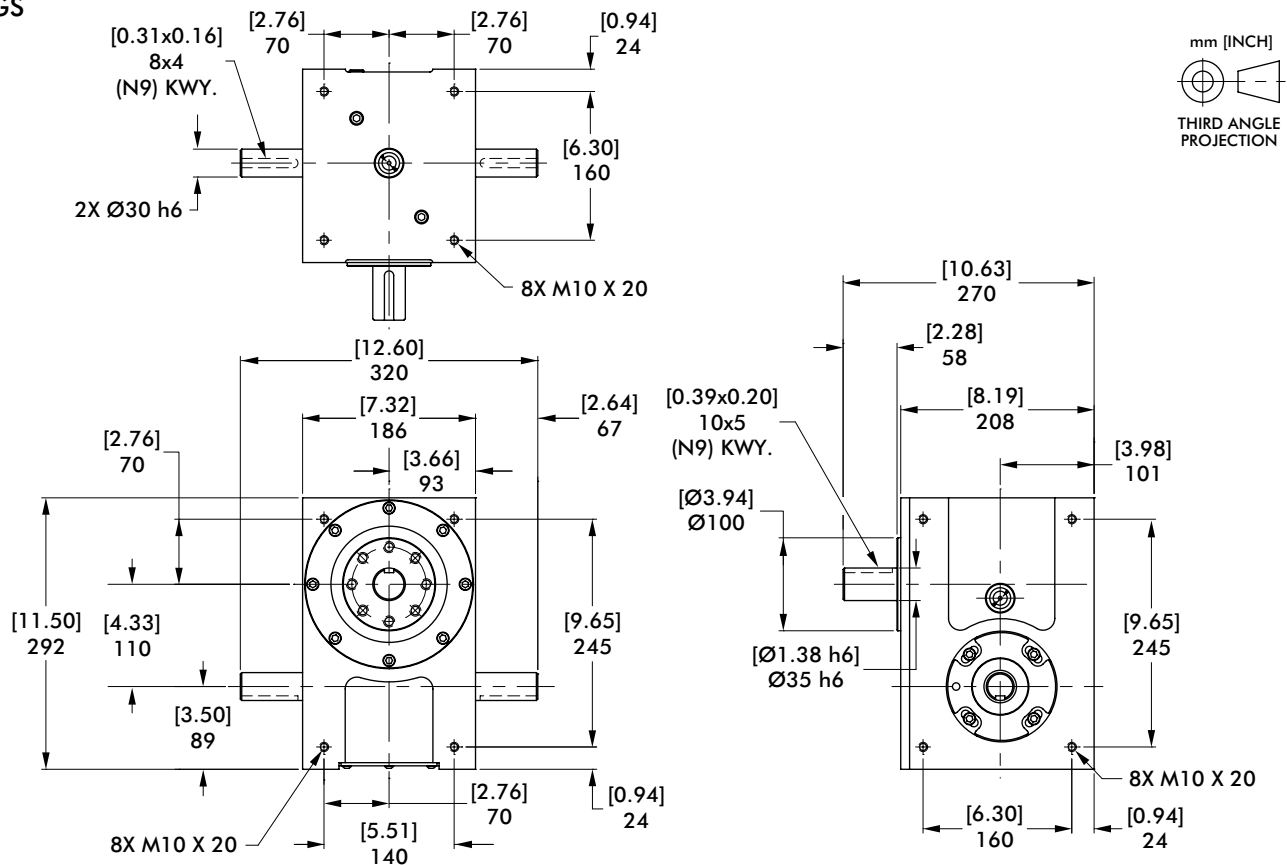

110RGD/110RGS SERIES

Roller Gear Index Drive | Features | Optional Accessories | Technical Information

110RGD/110RGS Indexer Capacities						
Stops	Index Period	Motion	B ₁ Capacity at 50 RPM N-m [in-lb]	RGD Internal Inertia kg-cm ² [lb-in ²]	RGS Internal Inertia kg-cm ² [lb-in ²]	Model
2	300	msc.33	596 [5271]	149,2 [51]	163,9 [56]	110RG(D/S)2H40-300
	270	msc.50	692 [6126]	149,2 [51]	163,9 [56]	110RG(D/S)2H40-270
3	270	ms	634 [5609]	149,2 [51]	163,9 [56]	110RG(D/S)3H40-270
	180	msc.50	885 [7829]	149,2 [51]	163,9 [56]	110RG(D/S)3H40-180
4	270	ms	371 [3282]	140,5 [48]	161,0 [55]	110RG(D/S)4H32-270
	180	msc.33	469 [4147]	140,5 [48]	161,0 [55]	110RG(D/S)4H32-180
6	270	ms	834 [7378]	152,2 [52]	204,8 [70]	110RG(D/S)6H48-270
	120	msc.33	918 [8127]	149,2 [51]	163,9 [56]	110RG(D/S)6H40-120
8	270	ms	389 [3440]	140,5 [48]	161,0 [55]	110RG(D/S)8H32-270
	120	ms	469 [4149]	140,5 [48]	161,0 [55]	110RG(D/S)8H32-120
12	270	ms	318 [2815]	137,5 [47]	161,0 [55]	110RG(D/S)12H28-270
	120	ms	380 [3367]	131,7 [45]	149,2 [51]	110RG(D/S)12H24-120
16	270	ms	182 [1610]	131,7 [45]	155,1 [53]	110RG(D/S)16H20-270
	120	ms	225 [1992]	131,7 [45]	155,1 [53]	110RG(D/S)16H20-120
24	270	ms	412 [3650]	131,7 [45]	149,2 [51]	110RG(D/S)24H24-270 II
	180	ms	467 [4134]	131,7 [45]	149,2 [51]	110RG(D/S)24H24-180 II

Other Motions (stops and index periods) available. Contact your DESTACO sales representative for more information.

Features

- Fully Metric
- Universal Mounting: mounting holes on any of 6 sides
- Center Through Hole (Ø45 mm [Ø1.77 in]) in RGD model.
- Right Hand Cam

Optional Accessories

- KH37 Reducer
 - Ratios from 5.36:1 to 106.38:1 (consult factory for exact ratios available)
 - 1 HP AC Drive Package with Inverter Duty Motor and Inverter Drive (up to 60 cpm)
- Single or Dual Cycle Cam and Limit Switch
- Left Hand Cam
- Relief in Dwell for shot-pin applications

Output Load Capacity (loads carried during index):

	RGD	RGS
Radial	24968 N [5613 lbs]	8256 N [1156 lbs]
Thrust/Axial	19621 N [4411 lbs]	9132 N [2053 lbs]
Moment in-lb]	1248 N-m [11050 in-lb]	479 N-m [4238]

Accuracy ±30 arcsec / ±0,023 mm [±.0009 in] at 152,4 mm [6 in] Radius

Repeatability ±8 arcsec / ±0,005 mm [±.0002 in] at 152,4 mm [6 in] Radius

350RGD/350RGS SERIES

Roller Gear Index Drive | Dimensions

350RGD

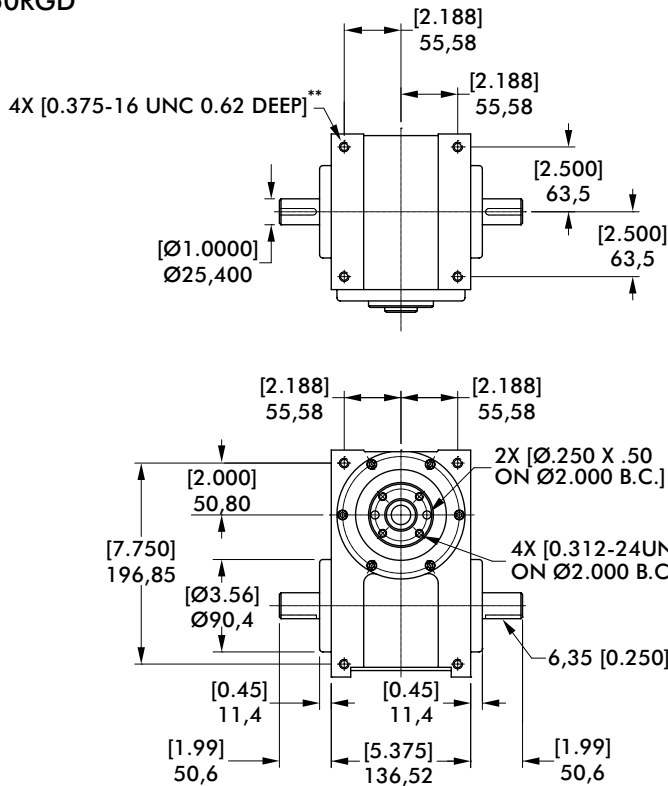

** 4 TAPPED MOUNTING HOLES IN ANY ONE OF SIX FINISHED SIDES, TO BE SPECIFIED BY CUSTOMER

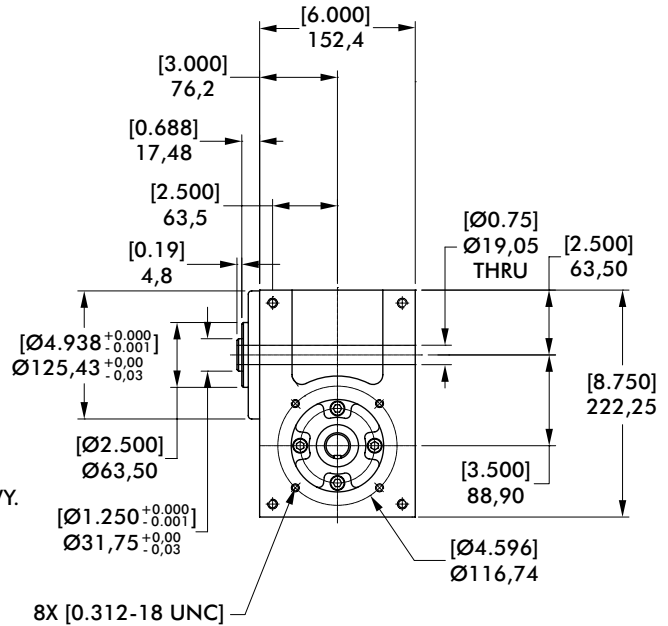

350RGS

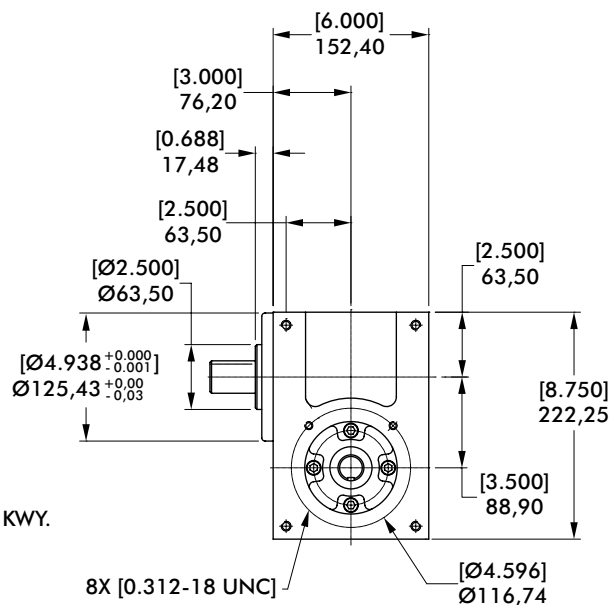
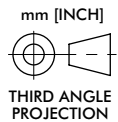
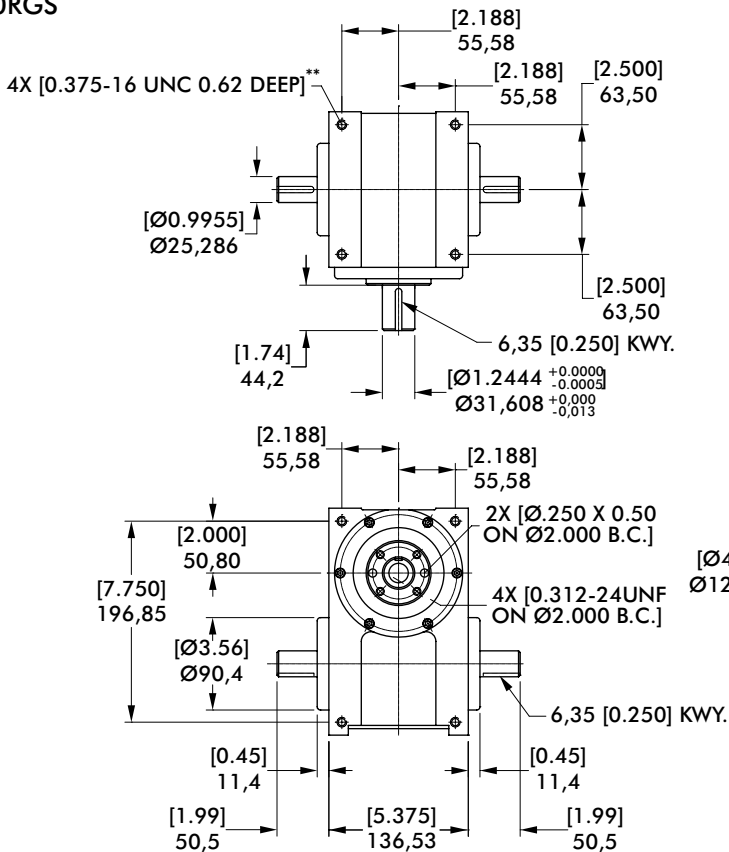

350RGD/350RGS SERIES

Roller Gear Index Drive | Features | Optional Accessories | Technical Information

350RGD/350RGS Indexer Capacities						
Stops	Index Period	Motion	B _e Capacity at 50 RPM N-m [in-lb]	RGD Internal Inertia kg-cm ² [lb-in ²]	RGS Internal Inertia kg-cm ² [lb-in ²]	Model
1	330	msc.50	200 [1774]	22,5 [7.7]	28,4 [9.7]	350RG(D/S)1H24-330
2	270	ms	141 [1244]	22,5 [7.7]	28,4 [9.7]	350RG(D/S)2H24-270
	180	msc.67	231 [2047]	22,5 [7.7]	28,4 [9.7]	350RG(D/S)2H24-180
3	270	ms	173 [1530]	22,5 [7.7]	28,4 [9.7]	350RG(D/S)3H24-270
	180	ms	181 [1601]	22,5 [7.7]	28,4 [9.7]	350RG(D/S)3H24-180
4	300	ms	192 [1701]	23,7 [8.1]	29,6 [10.1]	350RG(D/S)4H24-300
	180	ms	226 [2001]	23,7 [8.1]	29,6 [10.1]	350RG(D/S)4H24-180
6	270	ms	182 [1615]	22,5 [7.7]	28,4 [9.7]	350RG(D/S)6H24-270
	90	ms	233 [2063]	22,5 [7.7]	28,4 [9.7]	350RG(D/S)6H24-90
8	270	ms	208 [1840]	23,7 [8.1]	29,6 [10.1]	350RG(D/S)8H24-270
	90	ms	307 [2716]	23,7 [8.1]	29,6 [10.1]	350RG(D/S)8H24-90
12	270	ms	128 [1132]	23,1 [7.9]	29,0 [9.9]	350RG(D/S)12H20-270
	90	ms	167 [1476]	23,1 [7.9]	29,0 [9.9]	350RG(D/S)12H20-90

Other Motions (stops and index periods) available. Contact your DESTACO sales representative for more information.

Features

- Universal Mounting: mounting holes on any of 6 sides
- Center Through Hole (Ø19.05 mm [Ø.75 in]) in RGD model.
- Right Hand Cam Standard

Optional Accessories

- R180 Reducer (Ratios from 5:1 to 60:1)
 - 1/3 HP AC Drive Package with Inverter Duty Motor and Inverter Drive (up to 60 cpm)
 - 1/3 HP DC Motor with Varipak DC Motor Control (up to 30 cpm)
- R225 Reducer (Ratios from 5:1 to 60:1)
 - 56C Motor Adapter and Coupling
 - 1 HP AC Drive Package with Inverter Duty Motor and Inverter Drive (up to 60 cpm)
 - 1 HP DC Motor with Varipak DC Motor Control (up to 30 cpm)
- Single or Dual Cycle Cam and Limit Switch
- Relief in Dwell for shot-pin applications
- Left Hand Cam
- Relief in Dwell for shot-pin applications

Output Load Capacity (loads carried during index):

	RGD	RGS
Radial	8607 N [1935 lbs]	8042 N [1808 lbs]
Thrust/Axial	6254 N [1406 lbs]	3496 N [786 lbs]
Moment	273 N-m [2419 in-lb]	357 N-m [3164 in-lb]

Accuracy ±41 arcsec / ±0,030 mm [±.0012 in] at 152,4 mm [6 in] Radius

Repeatability ±10 arcsec / ±0,008 mm [±.0003 in] at 152,4 mm [6 in] Radius

500RGD/500RGS SERIES

Roller Gear Index Drive | Dimensions

500RGD

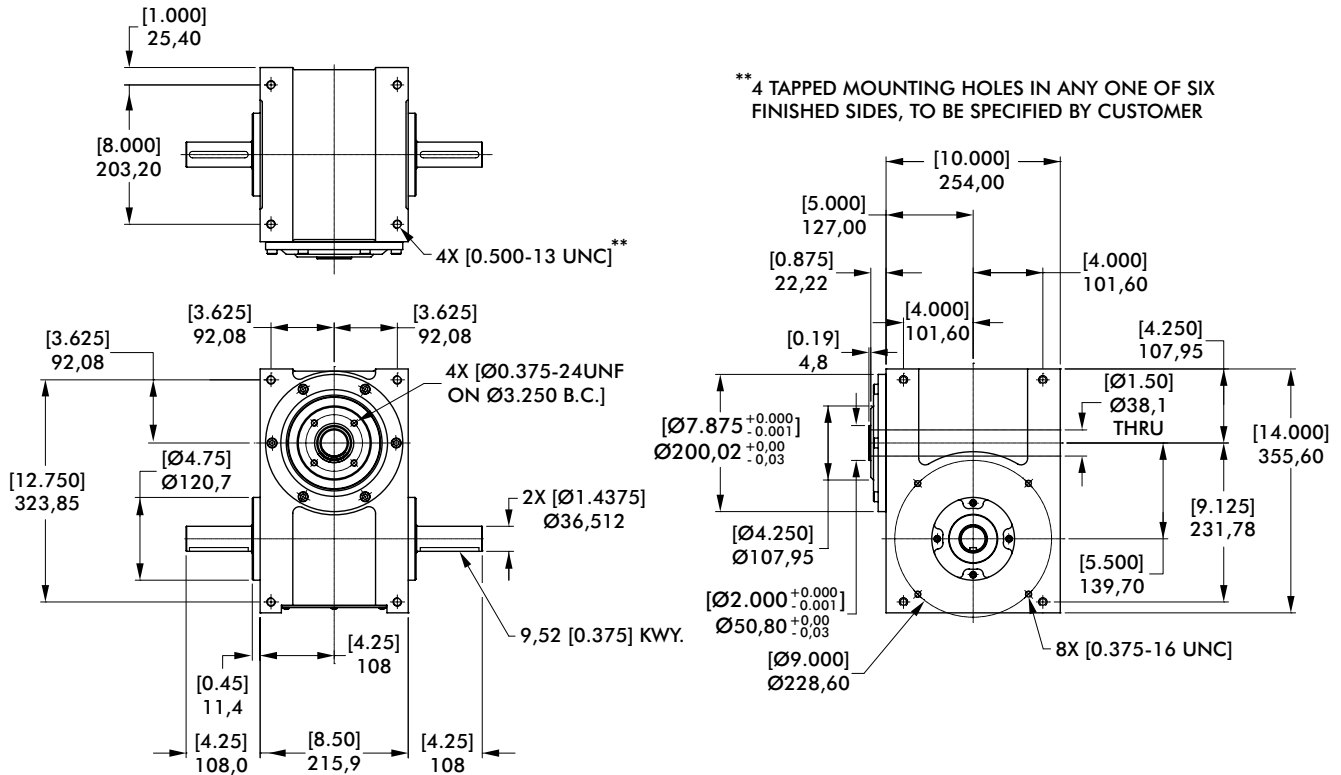

500RGS

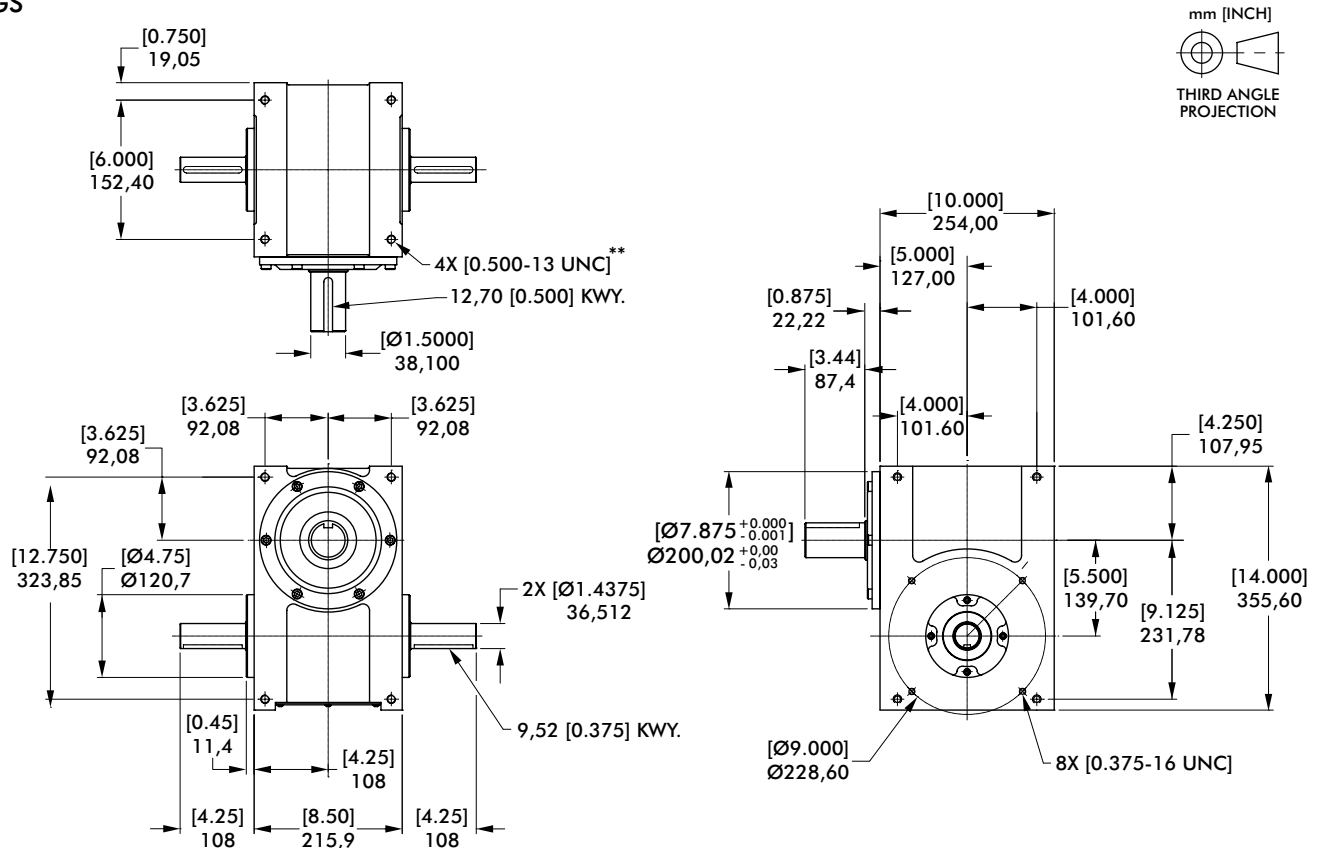

500RGD/500RGS SERIES

Roller Gear Index Drive | Features | Optional Accessories | Technical Information

500RGD/500RGS Indexer Capacities						
Stops	Index Period	Motion	B ₀ Capacity at 50 RPM N-m [in-lb]	RGD Internal Inertia kg-cm ² [lb-in ²]	RGS Internal Inertia kg-cm ² [lb-in ²]	Model
1	330	msc.60	765 [6767]	181,4 [62]	131,7 [45]	500RG(D/S)1H40-330
2	270	ms	497 [4400]	181,4 [62]	131,7 [45]	500RG(D/S)2H40-270
3	270	ms	595 [5265]	181,4 [62]	131,7 [45]	500RG(D/S)3H40-270
	180	ms	645 [5706]	181,4 [62]	131,7 [45]	500RG(D/S)3H40-180
4	270	ms	692 [6121]	193,1 [66]	140,5 [48]	500RG(D/S)4H40-270
	120	msc.20	440 [3892]	175,6 [60]	122,9 [42]	500RG(D/S)4H32-120
6	270	ms	617 [5464]	181,4 [62]	131,7 [45]	500RG(D/S)6H40-270
	90	ms	781 [6909]	181,4 [62]	131,7 [45]	500RG(D/S)6H40-90
8	270	ms	695 [6151]	193,1 [66]	140,5 [48]	500RG(D/S)8H40-270
	90	ms	929 [8219]	193,1 [66]	140,5 [48]	500RG(D/S)8H40-90
12	270	ms	296 [2616]	169,7 [58]	117,1 [40]	500RG(D/S)12H28-270
	90	ms	390 [3449]	169,7 [58]	117,1 [40]	500RG(D/S)12H28-90

Other Motions (stops and index periods) available. Contact your DESTACO sales representative for more information.

Features

- Universal Mounting: mounting holes on any of 6 sides
- Center Through Hole (Ø38.1 mm [Ø1.50 in]) in RGD model.
- Right Hand Cam Standard

Optional Accessories

- 1 hp AC Drive Package with Inverter Duty Motor and Inverter Drive (up to 60 cpm)
- 1 hp DC Motor with Varipak DC Motor Control (up to 30 cpm)
- Single or Dual Cycle Cam and Limit Switch
- Output Overload Clutch Models: 11S, 11C, 11F, 11C-SD, 11S-SD, 11FC-SD
 - Available Settings (in-lbs): 2300, 4000, 6000, 8500, 11000
- Left Hand Cam
- Relief in Dwell for shot-pin applications
- Left Hand Cam

Output Load Capacity (loads carried during index):

	RGD	RGS
Radial	17811 N [4004 lbs]	16756 N [3767 lbs]
Thrust/Axial	12273 N [2759 lbs]	6374 N [1433 lbs]
Moment	961 N-m [8509 in-lb]	1464 N-m [12959 in-lb]

Accuracy ±29 arcsec / ±0,020 mm [±.0008 in] at 152,4 mm [6 in] Radius

Repeatability ±7 arcsec / ±0,005 mm [±.0002 in] at 152,4 mm [6 in] Radius

600RGD/600RGS SERIES

Roller Gear Index Drive | Dimensions

600RGD

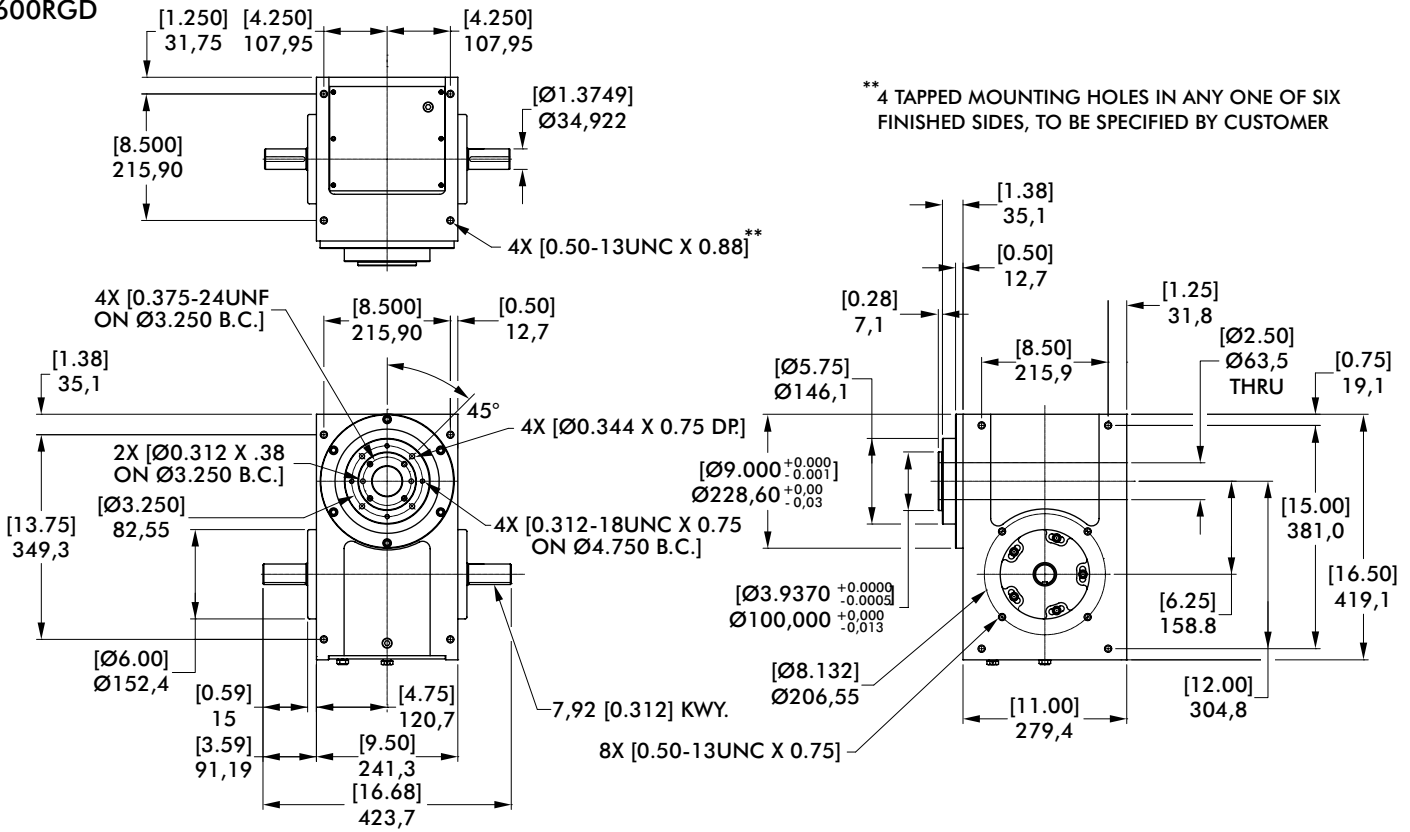

600RGS

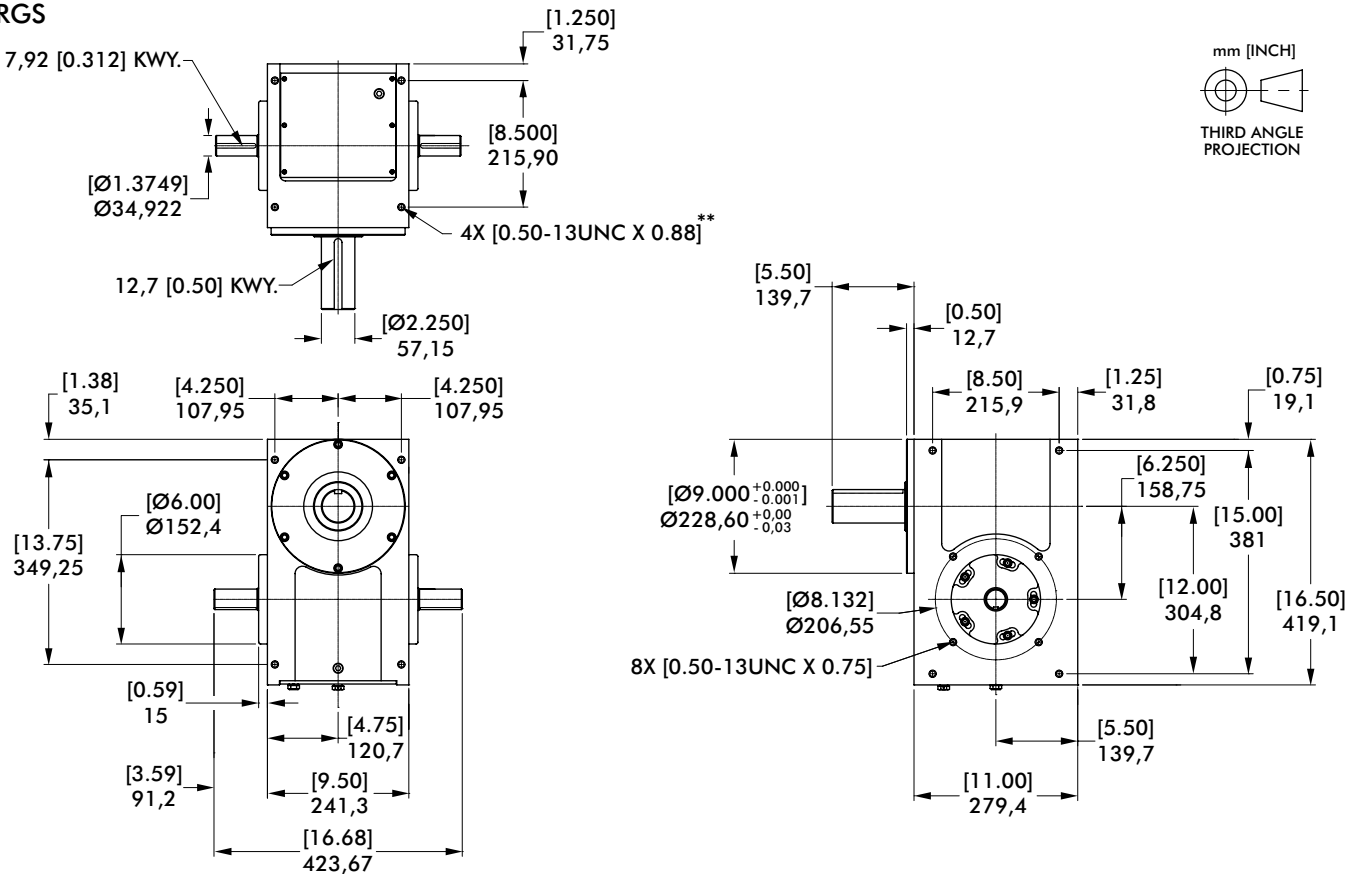

600RGD/600RGS SERIES

Roller Gear Index Drive | Features | Optional Accessories | Technical Information

600RGD/600RGS Indexer Capacities						
Stops	Index Period	Motion	B ₁₀ Capacity at 50 RPM N-m [in-lb]	RGD Internal Inertia kg-cm ² [lb-in ²]	RGS Internal Inertia kg-cm ² [lb-in ²]	Model
2	300	ms	736 [6516]	749,2 [256]	400,9 [137]	600RG(D/S)2H48-300
3	270	ms	899 [7955]	749,2 [256]	400,9 [137]	600RG(D/S)3H48-270
	180	ms	991 [8769]	749,2 [256]	400,9 [137]	600RG(D/S)3H48-180
4	270	ms	763 [6749]	728,7 [249]	383,4 [131]	600RG(D/S)4H40-270
	180	ms	845 [7477]	728,7 [249]	383,4 [131]	600RG(D/S)4H40-180
6	270	ms	936 [8286]	749,2 [256]	400,9 [137]	600RG(D/S)6H48-270
	90	ms	1211 [10715]	749,2 [256]	400,9 [137]	600RG(D/S)6H48-90
8	270	ms	783 [6928]	714 [244]	368,7 [126]	600RG(D/S)8H40-270
	90	ms	1010 [8936]	714 [244]	368,7 [126]	600RG(D/S)8H40-90
12	270	ms	462 [4091]	714 [244]	368,7 [126]	600RG(D/S)12H32-270
	90	ms	615 [5444]	714 [244]	368,7 [126]	600RG(D/S)12H32-90
16	270	ms	1079 [9553]	728,7 [249]	383,4 [131]	600RG(D/S)16H40-270 II
	90	ms	1381 [12224]	728,7 [249]	383,4 [131]	600RG(D/S)16H40-90 II

Other Motions (stops and index periods) available. Contact your DESTACO sales representative for more information.

Features

- Universal Mounting: mounting holes on any of 6 sides
- Center Through Hole (Ø63.5 mm [Ø2.50 in]) in RGD model.
- Right Hand Cam Standard

Optional Accessories

- 7300C or 7350C Reducer (Ratios from 5:1 to 60:1)
- 1 or 2 hp AC Drive Package with Inverter Duty Motor and Inverter Drive (up to 60 cpm)
- 1 or 2 hp DC Motor with Varipak DC Motor Control (up to 30 cpm)
- Single or Dual Cycle Cam and Limit Switch
- Output Overload Clutch Models: 11FM, 11SM
– Available Settings (in-lbs): 2300, 4000, 6000, 8500, 11000
- Left Hand Cam
- Relief in Dwell for shot-pin applications
- Left Hand Cam

Output Load Capacity (loads carried during index):

	RGD	RGS
Radial	25208 N [5667 lbs]	17028 N [3828 lbs]
Thrust/Axial	15693 N [3528 lbs]	15698 N [3529 lbs]
Moment	1841 N-m [16292 in-lb]	2085 N-m [18451 in-lb]

Accuracy ±40 arcsec / ±0,028 mm [±.0011 in] at 152,4 mm [6 in] Radius

Repeatability ±10 arcsec / ±0,008 mm [±.0003 in] at 152,4 mm [6 in] Radius

PRECISION INDEXING SOLUTIONS

Table of Contents

INDEXERS

Servo Positioners



GTB Series
Globoidal (Roller Gear)
Servo Positioner.....IN-SRV-1



RSD Series
Rotary Servo Drives.....IN-SRV-39

Mechanical Indexers



RDM Series
Rotary Index Drive IN-MCH-2



RD Series
Roller Dial Index Drive..... IN-MCH-18



E Series
Heavy-Duty Index Drive IN-MCH-30



RA Series
Right Angle Index Drive IN-MCH-42



RGD/RGS Series
Roller Gear Index Drive IN-MCH-52



P Series
Parallel Shaft/Flange Drive.... IN-MCH-72



RNG Series
Ring Drive Dial Indexer.....IN-MCH-84

OVERLOAD CLUTCHES



Overload Clutches
Output Overload..... IN-CLU-1

CUSTOM CAMS



Custom Cams
Cam Design Solutions IN-CAM-1

CONVEYORS



Rite-Link Series
Thin-Profile.....IN-CNV-1



Precision Link Series
Table-TopIN-CNV-4



Precision Link Series
Heavy-Duty IN-CNV-16

PARTS HANDLERS



LPP Series
Linear Part Handlers IN-PRT-2



RPP Series
Rotary Part Handlers IN-PRT-8

PARALLEL SHAFT/FLANGE DRIVES

Features | Table of Contents

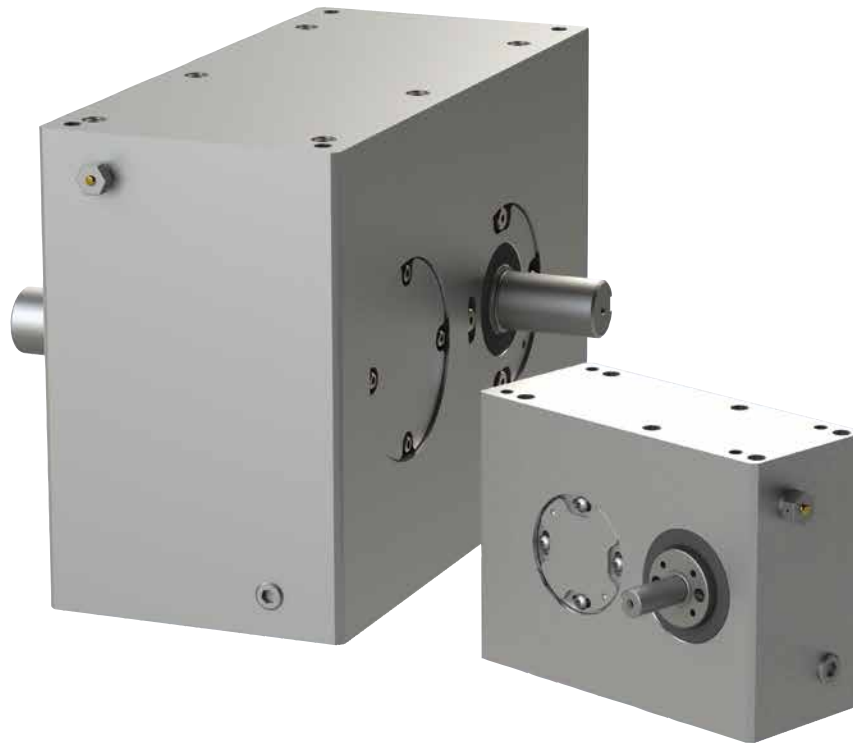

Features:

Camco Parallel Index Drives are ideal for high-speed applications or for actuation-type applications such as driving a linkage or a conveyor.

Hardened and ground conjugate cams

Yoke-mounted, preloaded cam followers are non-reversing for high capacity and speed capability

Whole or fractional stops, oscillating and complex custom motions are available

Long transfer distances achieved with simple linkages

Preloaded, tapered roller bearings for rigidity and backlash-free operation

Table of Contents

How to Order	3
250P.....	5
387P.....	7
512P.....	9
662P.....	11

P SERIES

Parallel Shaft/Flange Drives | How To Order

Indexer Ordering Procedure

1. Input Assembly: Right, Left or Double (DE)
2. Output Assembly: Right, Left or Double (DE).
 - Flanged output is primary output. For Double Output, specify whether flanged output is on right or left side.

NOTE: Input may rotate in either direction to achieve desired direction of output rotation.

3. Mounting Position: 1-6

Reducer Ordering Procedure

1. Model
2. Ratio: 5:1, 10:1, 15:1, 20:1, 25:1, 30:1, 40:1, 50:1, 60:1
3. Motor Adapter
4. Reducer Input Shaft Extension: Single Input (SE) or Double Input (DE)
5. Mounting (see diagram below)

Position of Shafts (Top View)

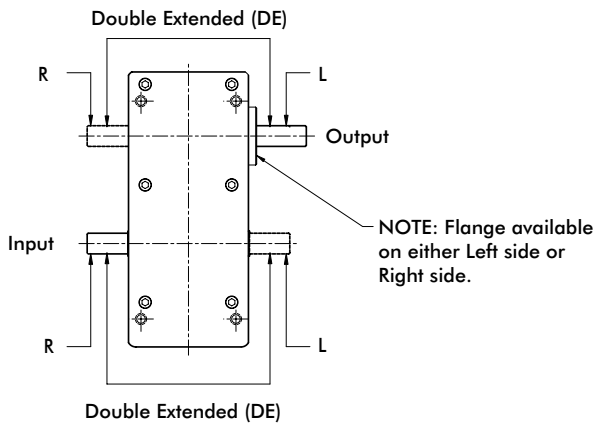

Input/Output Shaft Rotation

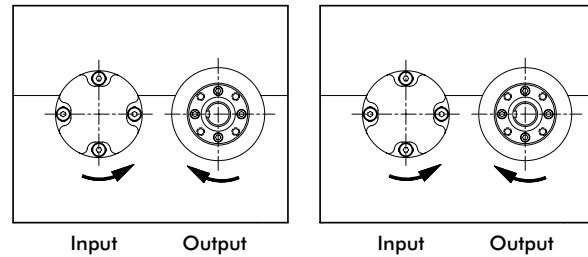

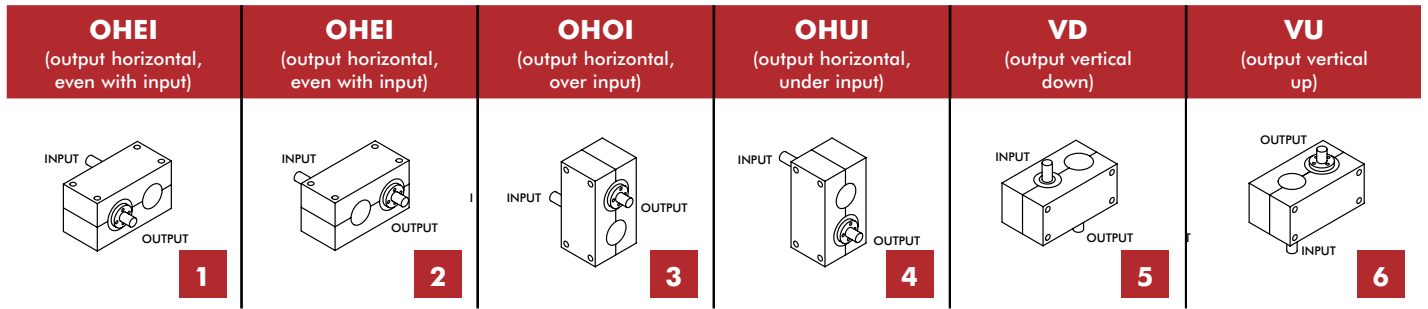

Gear Reducer Mounting Positions (Figure 4)

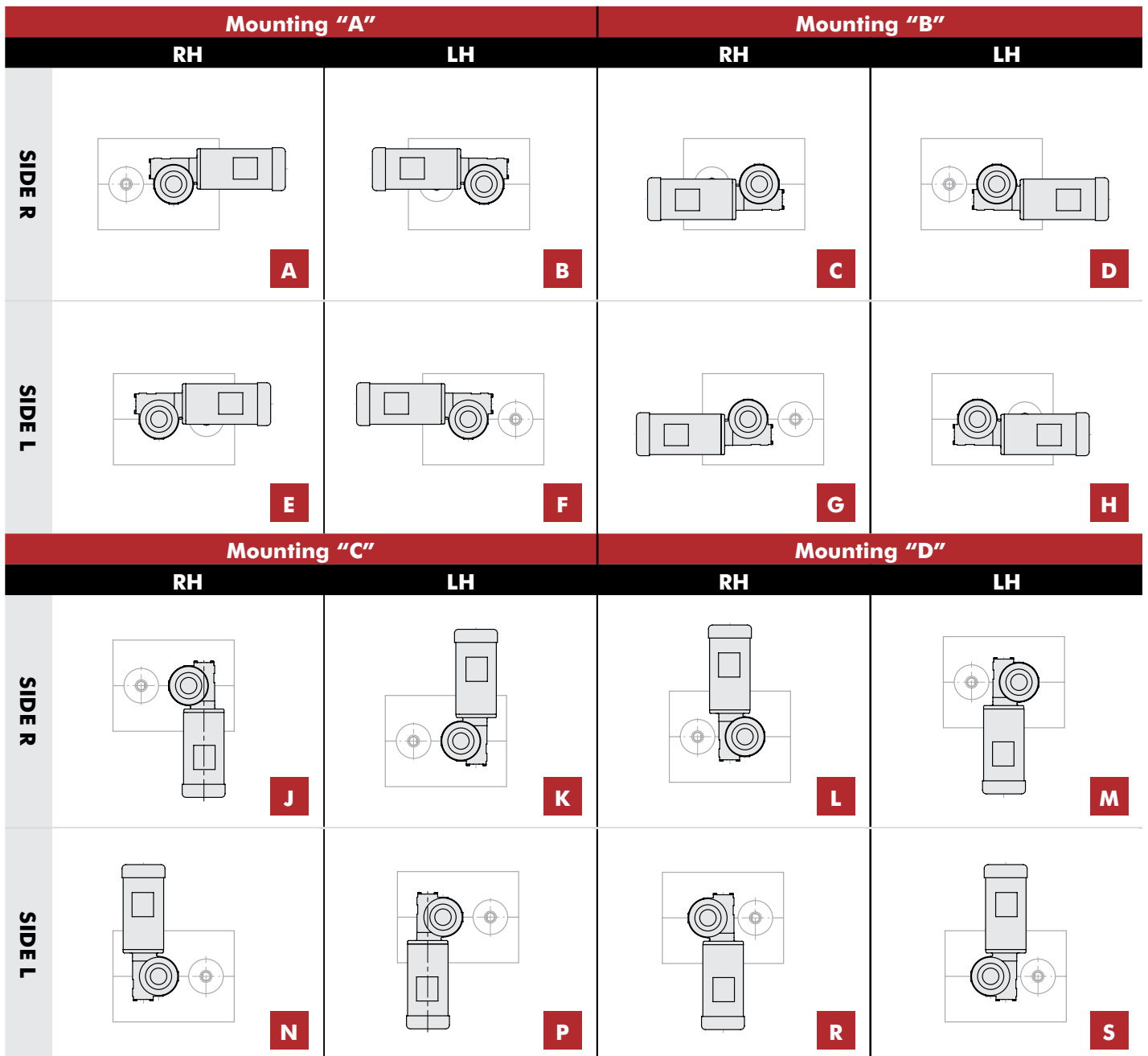

250P SERIES

Parallel Shaft/Flange Drives | Dimensions

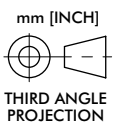
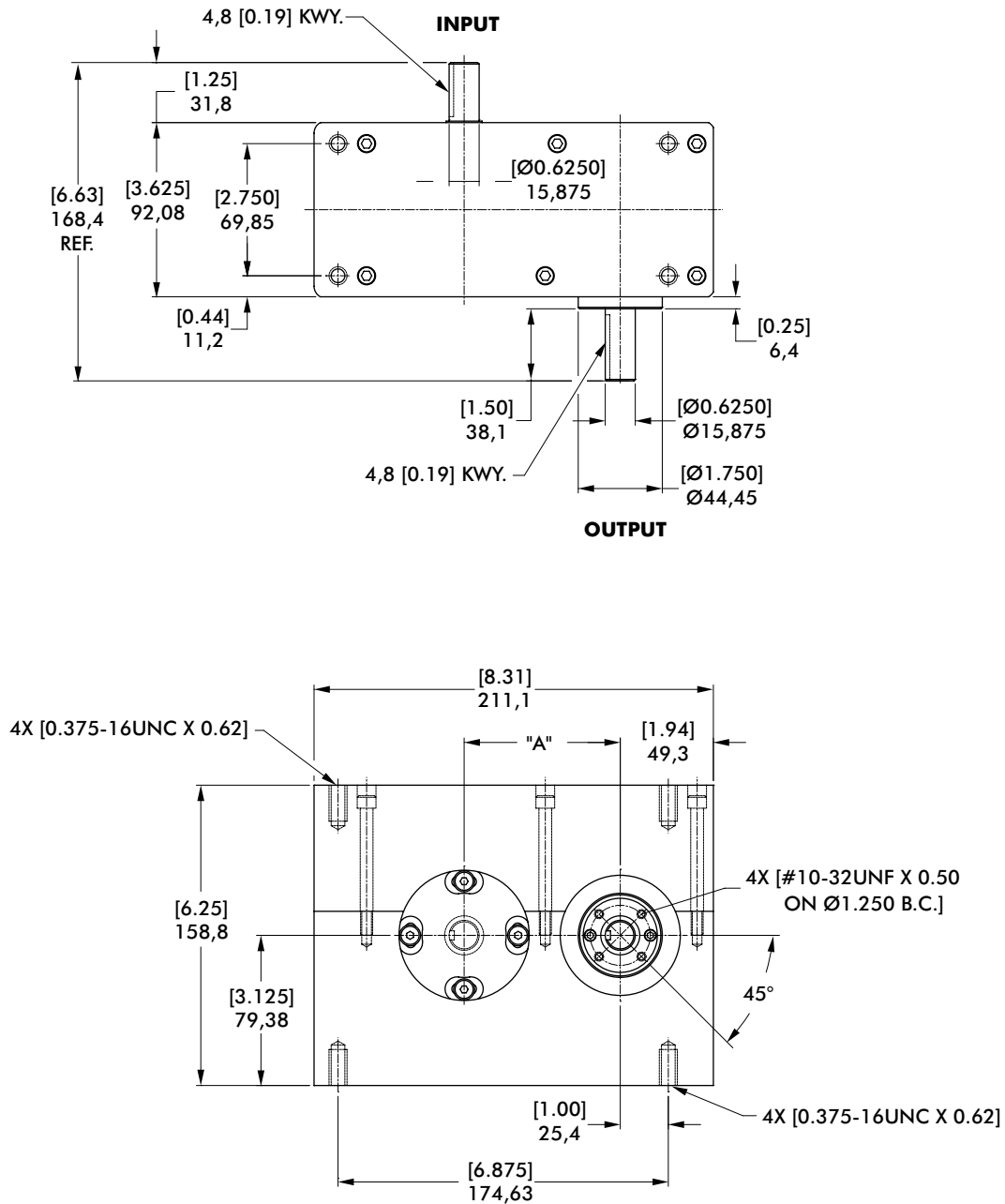

250P Indexer Capacities						
Stops	Index Period	Motion	B ₂ Capacity at 50 RPM N-m [in-lb]	Internal Inertia kg-cm ² [lb-in ²]	Model	"A" Center mm [in]
1	300	msc.50	50 [444]	8,8 [3]	250P1H20-300	82,6 [3.25]
1.5	270	msc.33	54 [481]	5,9 [2]	250P1.5H20-270	82,6 [3.25]
2	270	ms	49 [433]	8,8 [3]	250P2H20-270	82,6 [3.25]
	180	msc.33	62 [546]	8,8 [3]	250P2H20-180	82,6 [3.25]
3	270	ms	66 [582]	5,9 [2]	250P3H20-270	69,9 [2.75]
	120	ms	74 [653]	5,9 [2]	250P3H20-120	82,6 [3.25]
4	270	ms	65 [571]	8,8 [3]	250P4H20-270	69,9 [2.75]
	90	msc.25	88 [782]	8,8 [3]	250P4H20-90	82,6 [3.25]
6	270	ms	100 [888]	5,9 [2]	250P6H20-270 II	69,9 [2.75]
	180	msc.33	235 [2078]	8,8 [3]	250P6H24-180 II	69,9 [2.75]
8	270	ms	95 [843]	8,8 [3]	250P8H20-270 II	69,9 [2.75]
	120	ms	112 [993]	8,8 [3]	250P8H20-120 II	82,6 [3.25]

Other Motions (stops and index periods) available. Contact your DESTACO sales representative for more information.

Features

- Single Input Shaft and Single Output Shaft
- Output horizontal even with input Mounting
- R180 Reducer (ratios from 15:1 to 60:1)
 - Double Extended Worm (input) Shaft
 - Worm Shaft Handwheel
- 1/3 or 1 HP AC Drive Package with Inverter Duty Motor and Inverter Drive (up to 60 cpm)
- Single Cycle Cam and Limit Switch

Output Load Capacity (loads carried during index):

Radial	1406 N [316 lbs]
Thrust/Axial	1397 N [314 lbs]
Moment	45 N-m [395 in-lb]

Accuracy

±77 arcsec / ±0,028 mm [±.0011 in] at 76,2 mm [3 in] Radius

Repeatability

±19 arcsec / ±0,008 mm [±.0003 in] at 76,2 mm [3 in] Radius

Optional Accessories

- 1/3 hp DC motor
- Varipak DC Motor Control (up to 30 cpm)
- R225 Reducer (ratios from 10:1 to 60:1)
 - 1 hp AC or DC drive package
 - 56C Motor Adapter and Coupling
- Output Overload Clutch Models: .39F, .39FC, .39S and .39C, .39C-SD, .39FC-SD, .39S-SD
 - Available Settings (in-lb): 160, 210, 270, 320, 390
- Dual Cycle Cam and Limit Switch
- Oscillating motion
- Double Input Shaft
- Double Output Shaft
- Output and Input Vertical Mounting

387P SERIES

Parallel Shaft/Flange Drives | Dimensions

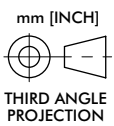
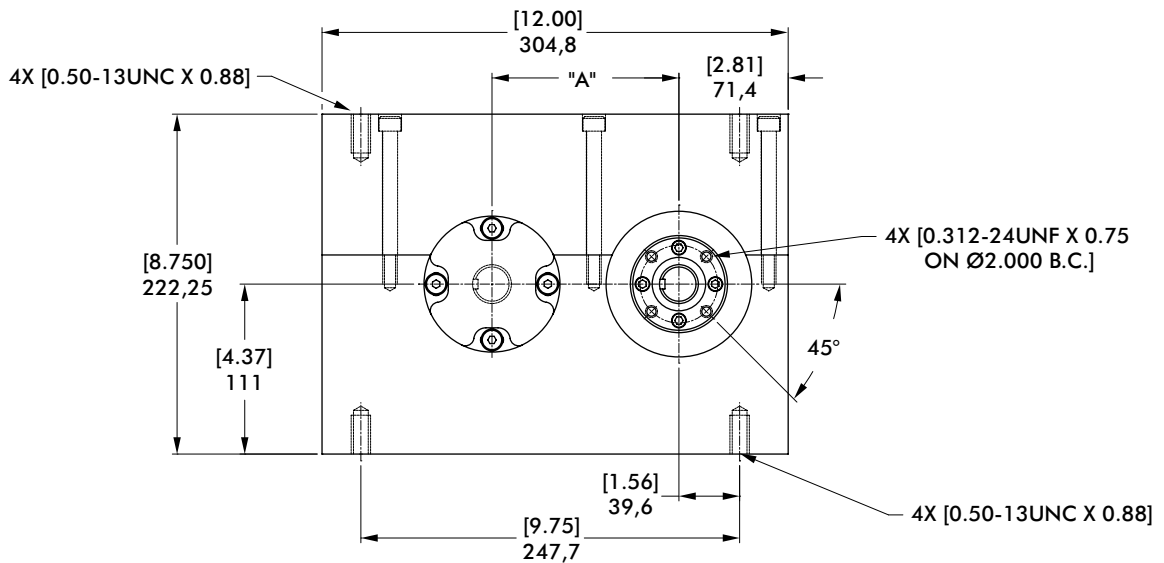
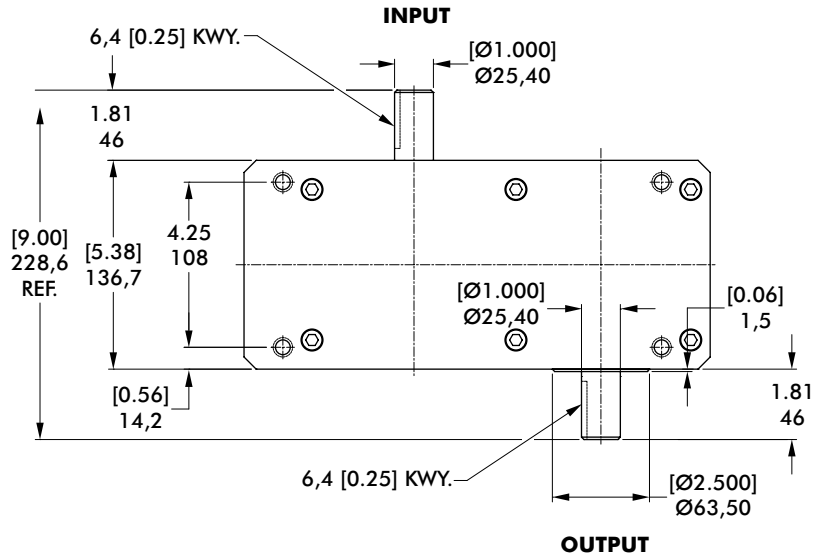

387P Indexer Capacities						
Stops	Index Period	Motion	B. Capacity at 50 RPM N-m [in-lb]	Internal Inertia kg-cm ² [lb-in ²]	Model	"A" Center mm [in]
1	300	msc.66	156 [1385]	41,0 [14]	387P1H28-300	122,22 [4.812]
1.33	315	msc.10	120 [1062]	38,0 [13]	387P1.33H28-315	122,22 [4.812]
1.5	300	ms	124 [1099]	38,0 [13]	387P1.5H28-300	122,22 [4.812]
2	270	msc.33	202 [1788]	41,0 [14]	387P2H32-270	122,22 [4.812]
	180	msc.33	237 [2095]	41,0 [14]	387P2H32-180	122,22 [4.812]
2.67	270	msc.33	245 [2171]	41,0 [14]	387P2.67H28-270 II	122,22 [4.812]
3	270	ms	181 [1601]	38,0 [13]	387P3H28-270	101,60 [4.000]
	120	msc.33	234 [2067]	41,0 [14]	387P3H28-120	122,22 [4.812]
4	270	ms	181 [1605]	41,0 [14]	387P4H28-270	101,60 [4.000]
	90	msc.33	250 [2214]	41,0 [14]	387P4H28-90	122,22 [4.812]
6	270	ms	276 [2445]	38,0 [13]	387P6H28-270 II	101,60 [4.000]
	180	ms	278 [2463]	38,0 [13]	387P6H28-180 II	122,22 [4.812]
8	270	ms	269 [2378]	41,0 [14]	387P8H28-270 II	101,60 [4.000]

Other Motions (stops and index periods) available. Contact your DESTACO sales representative for more information.

Features

- Single Input Shaft and Single Output Shaft
- Output horizontal even with input Mounting
- R225 Reducer (ratios from 10:1 to 60:1)
 - 56C Motor Adapter and Coupling
- 1 HP AC Drive Package with Inverter Duty Motor and Inverter Drive (up to 60 cpm)
- Single Cycle Cam and Limit Switch

Output Load Capacity (loads carried during index):

- Radial 3981 N [895 lbs]
- Thrust/Axial 2567 N [577 lbs]
- Moment 183 N-m [1620 in-lb]

Accuracy

±50 arcsec / ±0,018 mm [±.0007 in] at 76,2 mm [3 in] Radius

Repeatability

±12 arcsec / ±0,005 mm [±.0002 in] at 76,2 mm [3 in] Radius

Optional Accessories

- 1 hp DC motor
- Varipak DC Motor Control (up to 30 cpm)
- R260 Reducer (ratios from 5:1 to 60:1)
 - 1 hp AC or DC drive package
 - 56C Motor Adapter and Coupling
- Output Overload Clutch Models: 2.3F, 2.3FC, 2.3S and 2.3C, 2.3C-SD, 2.3FC-SD, 2.3S-SD
 - Available Settings (in-lb): 400, 600, 700, 850, 1000, 1300, 1800, 2000, 2300
- Dual Cycle Cam and Limit Switch
- Oscillating motion
- Double Input Shaft
- Double Output Shaft
- Output and Input Vertical Mounting

512P SERIES

Parallel Shaft/Flange Drives | Dimensions

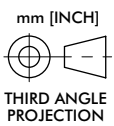
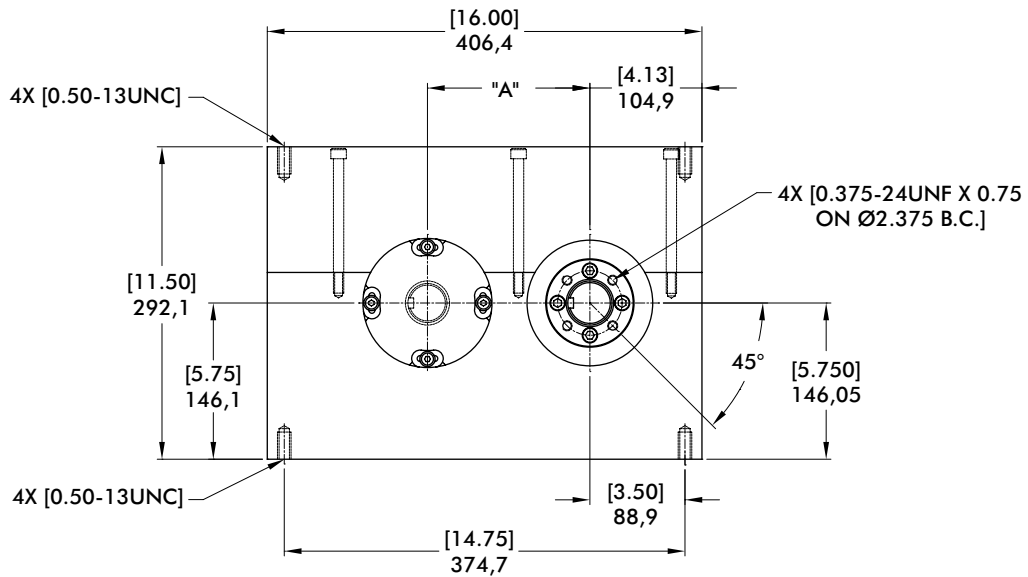
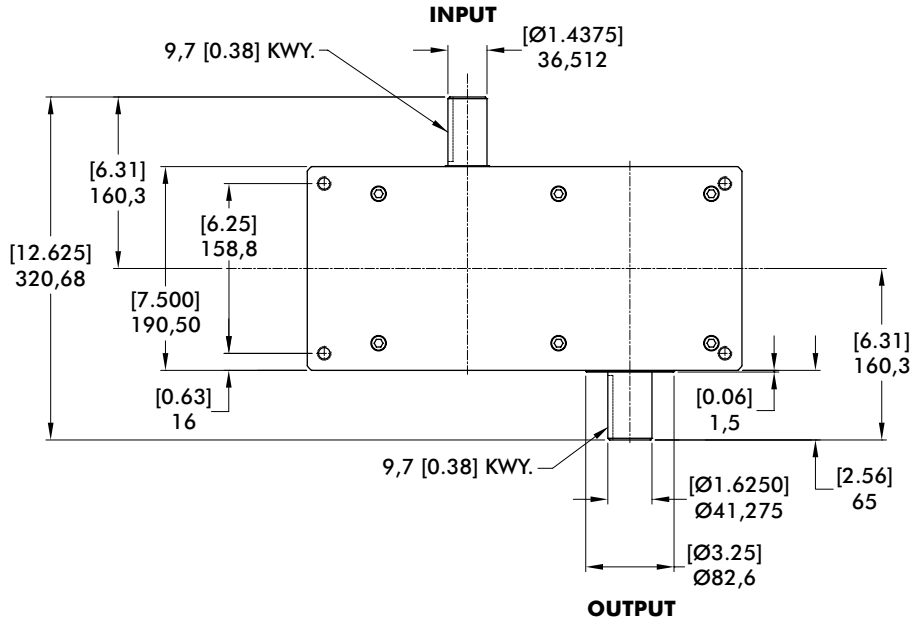

512P Indexer Capacities						
Stops	Index Period	Motion	B ₀ Capacity at 50 RPM N-m [in-lb]	Internal Inertia kg-cm ² [lb-in ²]	Model	"A" Center mm [in]
1	330	msc.75	728 [6441]	184,4 [63]	512P1H48-330	151,87 [5.979]
1.33	330	msc.33	557 [4928]	178,5 [61]	512P1.33H48-330	151,87 [5.979]
1.5	330	ms	549 [4860]	184,4 [63]	512P1.5H48-330	151,87 [5.979]
	270	msc.33	494 [4373]	178,5 [61]	512P2H40-270	151,87 [5.979]
2	180	msc.50	612 [5416]	178,5 [61]	512P2H40-180	151,87 [5.979]
	120	msc.50	467 [4131]	178,5 [61]	512P2H40-120	151,87 [5.979]
3	300	msc.33	804 [7116]	178,5 [61]	512P2.67H40-300 II	151,87 [5.979]
	180	ms	617 [5462]	163,9 [56]	512P3H40-180	151,87 [5.979]
4	270	ms	635 [5619]	178,5 [61]	512P4H40-270	123,39 [4.858]
	120	ms	706 [6252]	178,5 [61]	512P4H40-120	151,87 [5.979]
6	270	ms	939 [8315]	163,9 [56]	512P6H40-270 II	123,39 [4.858]
	180	ms	933 [8261]	163,9 [56]	512P6H40-180 II	151,87 [5.979]
8	270	ms	948 [8387]	178,5 [61]	512P8H40-270 II	123,39 [4.858]
	180	ms	892 [7894]	178,5 [61]	512P8H40-180 II	151,87 [5.979]

Other Motions (stops and index periods) available. Contact your DESTACO sales representative for more information.

Features

- Single Input Shaft and Single Output Shaft
- Output horizontal even with input Mounting
- R225 Reducer (ratios from 10:1 to 60:1)
 - 56C Motor Adapter and Coupling
- 1 HP AC Drive Package with Inverter Duty Motor and Inverter Drive (up to 60 cpm)
- Single Cycle Cam and Limit Switch

Output Load Capacity (loads carried during index):

Radial	12077 N [2715 lbs]
Thrust/Axial	6112 N [1374 lbs]
Moment	785 N-m [6951 in-lb]

Accuracy

±37 arcsec / ±0,013 mm [±.0005 in] at 76,2 mm [3 in] Radius

Repeatability

±9 arcsec / ±0,003 mm [±.0001 in] at 76,2 mm [3 in] Radius

Optional Accessories

- 1 hp DC motor
- Varipak DC Motor Control (up to 30 cpm)
- R260 Reducer (ratios from 5:1 to 60:1)
 - 1 hp AC or DC drive package
 - 56C Motor Adapter and Coupling
- Output Overload Clutch Models: 6.0F, 6.0FC, 6.0S and 6.0C, 6.0C-SD, 6.0FC-SD, 6.0S-SD
 - Available Settings (in-lb): 670, 825, 1100, 1400, 1700, 2000, 2300, 2500, 3000, 3800, 4000, 5000, 6000
- Dual Cycle Cam and Limit Switch
- Oscillating motion
- Double Input Shaft
- Double Output Shaft
- Output and Input Vertical Mounting

662P SERIES

Parallel Shaft/Flange Drives | Dimensions

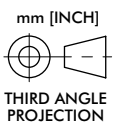
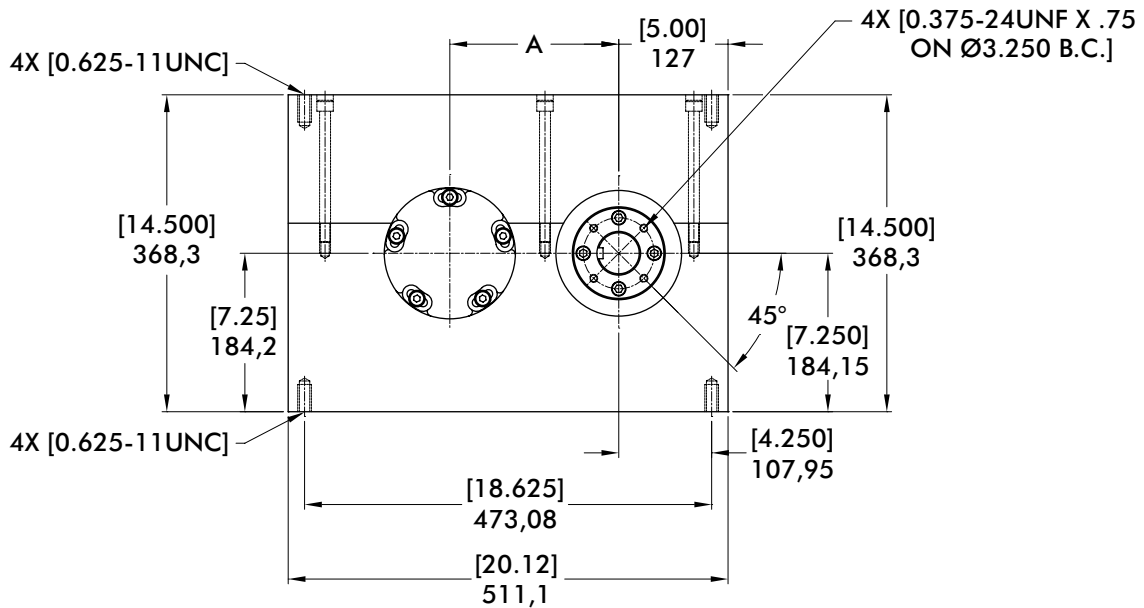
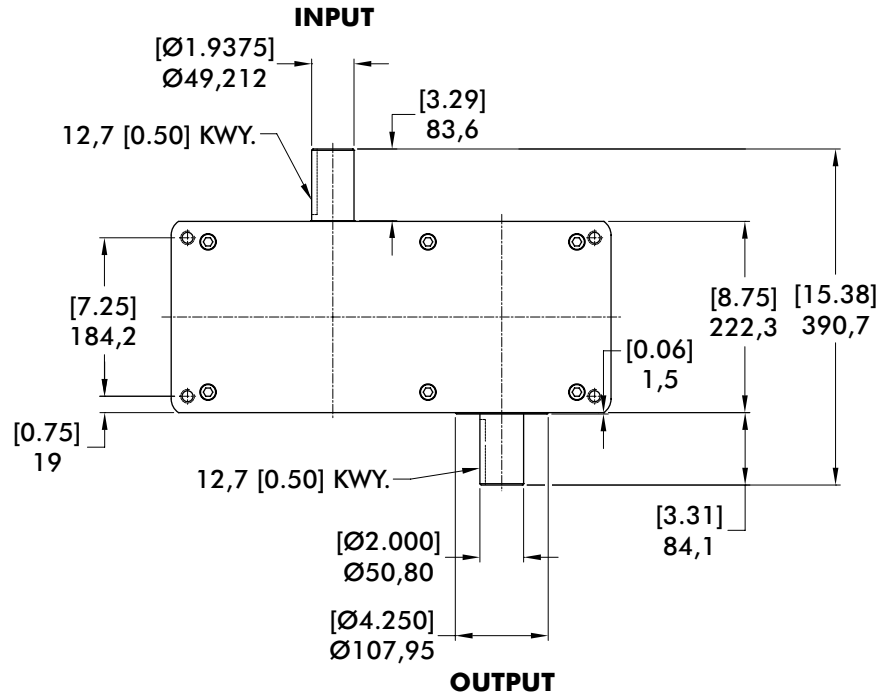

662P Indexer Capacities						
Stops	Index Period	Motion	B ₀ Capacity at 50 RPM N-m [in-lb]	Internal Inertia kg-cm ² [lb-in ²]	Model	"A" Center mm [in]
1	330	msc.50	658 [5824]	403,8 [138]	662P1H48-330	196,32 [7.729]
1.33	330	msc.20	1171 [10368]	971,6 [332]	662P1.33H64-330	196,32 [7.729]
1.5	270	msc.33	1425 [12617]	895,5 [306]	662P1.5H64-270	196,32 [7.729]
2	270	msc.33	770 [6811]	529,7 [181]	662P2H48-270	196,32 [7.729]
	180	msc.50	1329 [11760]	597,0 [204]	662P2H56-180	196,32 [7.729]
3	270	ms	954 [8446]	485,8 [166]	662P3H48-270	168,35 [6.628]
	180	ms	961 [8506]	485,8 [166]	662P3H48-180	196,32 [7.729]
4	270	ms	989 [8752]	529,7 [181]	662P4H48-270	168,35 [6.628]
	120	ms	1100 [9738]	529,7 [181]	662P4H48-120	196,32 [7.729]
6	270	ms	1463 [12946]	485,8 [166]	662P6H48-270 II	168,35 [6.628]
	180	ms	1453 [12863]	485,8 [166]	662P6H48-180 II	196,32 [7.729]
8	270	ms	1476 [13060]	529,7 [181]	662P8H48-270 II	168,35 [6.628]
	120	msc.33	1783 [15780]	529,7 [181]	662P8H48-120	196,32 [7.729]

Other Motions (stops and index periods) available. Contact your DESTACO sales representative for more information.

Features

- Single Input Shaft and Single Output Shaft
- Output horizontal even with input Mounting
- R225 Reducer (ratios from 10:1 to 60:1)
 - 56C Motor Adapter and Coupling
- 1 HP AC Drive Package with Inverter Duty Motor and Inverter Drive (up to 60 cpm)
- Single Cycle Cam and Limit Switch

Output Load Capacity (loads carried during index):

Radial	17415 N [3915 lbs]
Thrust/Axial	9083 N [2042 lbs]
Moment	1464 N-m [12959 in-lb]

Accuracy

±36 arcsec / ±0,025 mm [±.001 in] at 76,2 mm [3 in] Radius

Repeatability

±9 arcsec / ±0,008 mm [±.0003 in] at 152,4 mm [6 in] Radius

Optional Accessories

- 7350C or 7400C Reducer (ratios from 5:1 to 60:1) with Motor Adapter and Coupling
- 1 hp DC Motor
- Output Overload Clutch Models: 11F, 11FC, 11FC-SD
 - Available Settings (in-lb): 2300, 4000, 6000, 8500, 11000
- Dual Cycle Cam and Limit Switch
- Electric Clutch-Brake
- Air Clutch-Brake
- Oscillating motion
- Double Input Shaft
- Double Output Shaft
- Output and Input Vertical Mounting

PRECISION INDEXING SOLUTIONS

Table of Contents

INDEXERS

Servo Positioners



GTB Series
Globoidal (Roller Gear)
Servo Positioner.....IN-SRV-1

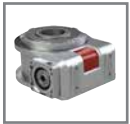

RSD Series
Rotary Servo Drives.....IN-SRV-39

Mechanical Indexers



RDM Series
Rotary Index Drive IN-MCH-2



RD Series
Roller Dial Index Drive..... IN-MCH-18



E Series
Heavy-Duty Index Drive IN-MCH-30



RA Series
Right Angle Index Drive IN-MCH-42



RGD/RGS Series
Roller Gear Index Drive IN-MCH-52



P Series
Parallel Shaft/Flange Drive.... IN-MCH-72



RNG Series
Ring Drive Dial Indexer.....IN-MCH-84

OVERLOAD CLUTCHES



Overload Clutches
Output Overload..... IN-CLU-1

CUSTOM CAMS



Custom Cams
Cam Design Solutions IN-CAM-1

CONVEYORS



Rite-Link Series
Thin-Profile.....IN-CNV-1



Precision Link Series
Table-TopIN-CNV-4



Precision Link Series
Heavy-Duty IN-CNV-16

PARTS HANDLERS



LPP Series
Linear Part Handlers IN-PRT-2



RPP Series
Rotary Part Handlers IN-PRT-8

RING DRIVE DIAL INDEXER

Features | How To Order

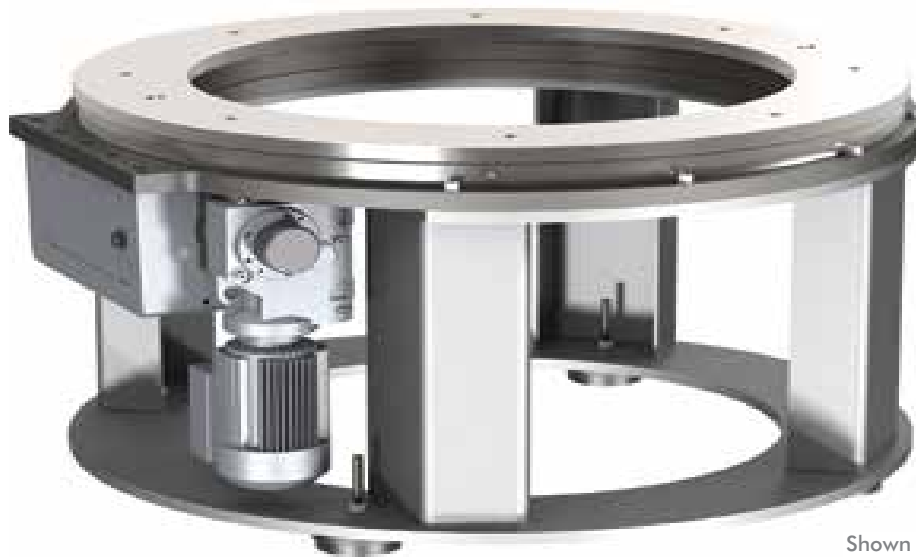

Shown with optional base

Work from Within

The **CAMCO Ring Drive** offers easy-to-integrate automation that fits easily into your operations.

Minimize machine footprint: Mount your equipment inside the through-hole of the CAMCO Ring Drive.

Easily tool the ring drive: Attach fixtures directly to the dial ring, eliminating the need for an additional dial plate.

Best technical support and service: Worldwide access to our global network.

Applications

Printing and decorating machines

Rotary automatic assembly machines

Ideal for assembly systems requiring a large number of tooling stations

The Ring Drive can replace a small conveyor

Table of Contents

How to Order	3
750RNG	5
1100RNG	7
1550RNG	9

Licensed under U.S. Patent No. 5,950,503

RNG SERIES

Ring Drive Dial Indexer | Features and Benefits | How to Order

Base Model Description

- 750RNG** w/ KH37 reducer & 1 HP AC motor (220/440V)
- 1100RNG** w/ KH37 reducer & 1 HP AC motor (220/440V)
- 1550RNG** w/ KH37 reducer & 1-1/2 HP AC motor (220/440V)

Control Description

- 1** 1 HP 120V 750RNG & 1100RNG only
- 2** 1 HP 240V 750RNG & 1100RNG only
- 3** 1 HP 440V 750RNG & 1100RNG only
- 4** 2 HP 240V 1550RNG only
- 5** 2 HP 440V 1550RNG only

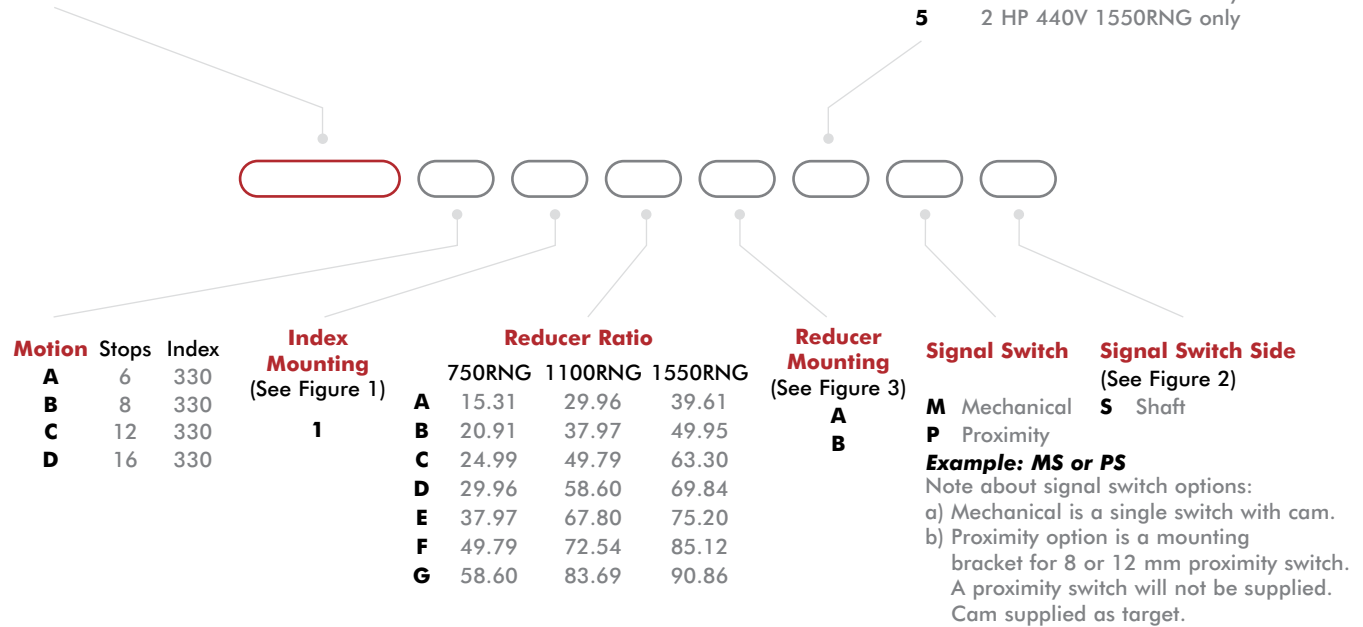

Other Motions (stops and index periods) available. Contact your DESTACO sales representative for more information.

Ring Drive Features

Great Design Flexibility

Available in three sizes (Ø): .75 m [29.53 in], 1.1 m [43.31 in] and 1.6 m [62.99 in]

Complete motorized drive package with reducer and AC inverter drive to suit most applications

Dial Ring can be removed for machining to mounting your tooling and fixtures.

Large center through-hole to accommodate auxiliary equipment

60 station capability, ideal for multiple part automatic assembly machines

Steel Dial Ring or optional Aluminum Ring

Broad range of motions/drive packages

Robust And Reliable

Superior accuracy, similar to a precision link conveyor - your work station is located over the cam for maximum accuracy.

High precision, hardened cams available in standard and special motions

Sealed 4-point contact output bearing and large cam followers for superior accuracy and load capability (models 750RNG, 1100RNG and 1550RNG)

Modular shaft-mounted reducers for application flexibility and easy maintenance

Access to cam followers for easy inspection and replacement

Tapered roller bearings on camshaft

Input Shaft Configuration/Rotations (Figure 1)

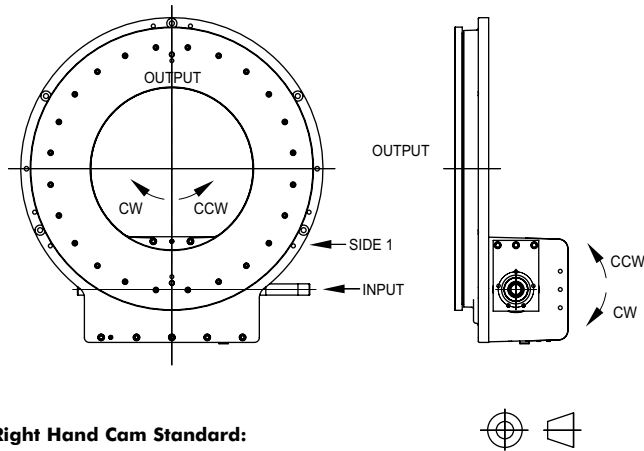

Right Hand Cam Standard:

CW Input Side 1, CCW Output

CCW Input Side 1, CW Output

NOTE: Input can be driven in either direction

Signal Switch Mounting Position (Figure 2)

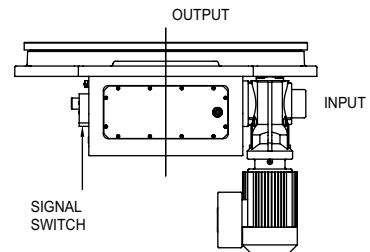

Gear Reducer Mounting Positions (Figure 3)

MOUNTING "A"

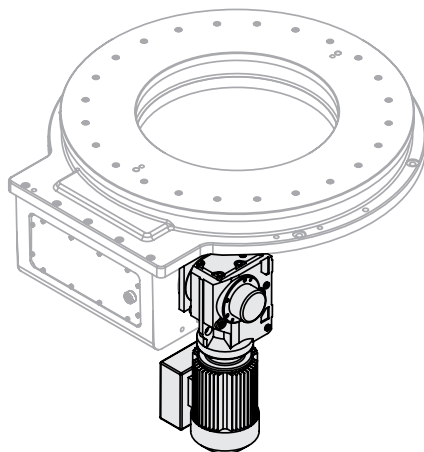

MOUNTING "B"

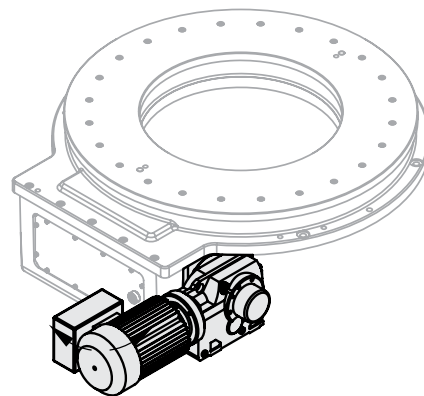

750RNG SERIES

Ring Drive Dial Indexer | Dimensions

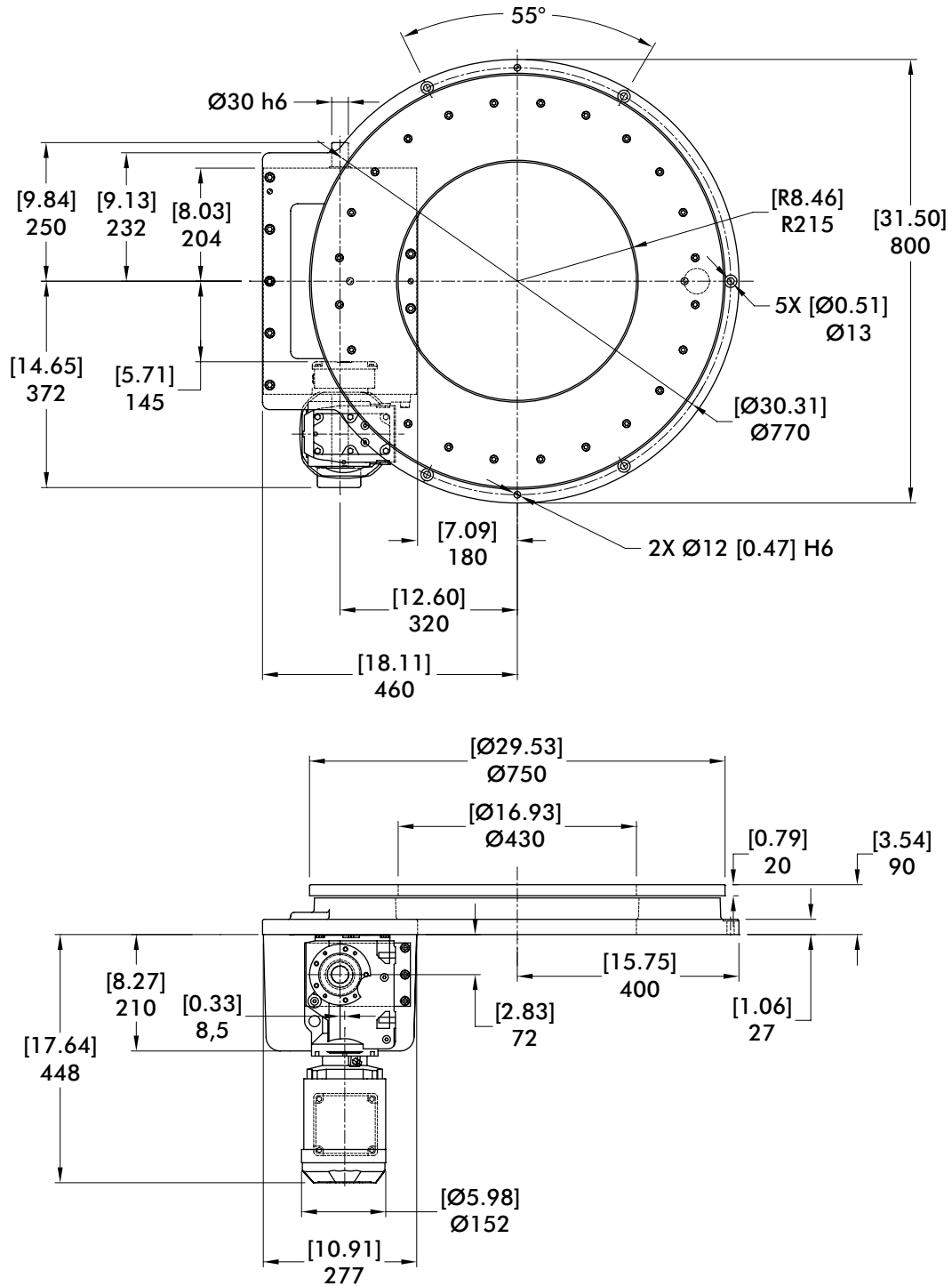

mm [INCH]

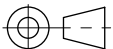

THIRD ANGLE
PROJECTION

Maximum Inertia x 1000 kg-cm ² [lb-in ²] for standard package							
Stops	Motion Time [seconds]						
	0.468	0.617	0.764	0.915	1.160	1.521	1.791
6	0 [0]	50 [17]	170 [58]	363 [124]	855 [292]	1653 [565]	2315 [791]
8	9 [3]	138 [47]	354 [121]	696 [238]	1571 [537]	2991 [1022]	4167 [1424]
12	105 [36]	392 [134]	878 [300]	1650 [564]	3620 [1237]	6813 [2328]	9461 [3233]
16	237 [81]	746 [255]	1610 [550]	2982 [1019]	6488 [2217]	12162 [4156]	16871 [5765]
Reducer Ratio							
	15.31	20.19	24.99	29.96	37.97	49.79	58.60

Features

- KH37 Reducer (Ratios from 15.31:1 to 58.6:1)
- 1 HP AC Drive Package with Inverter Duty Motor and IM-pAC AC Drive (up to 60 cpm)
- Double Extended Camshaft (Input Shaft)
- Center Thru Hole (Ø230 mm [Ø9.05 in])
- Cycle Cam and Limit Switch Mounted to Camshaft
- Right Hand Cam

Output Bearing Capacity (loads carried during index):

Radial	25740 N [5580 lbs]
Axial	64020 N [14550 lbs]
Moment	6915 N-m [61200 in-lbs]

Accuracy ±60 arcsec / ±0,047 mm [±.0019 in] at 324 mm [12.75 in] Radius

Repeatability ±15 arcsec / ±0,012 mm [±.0005 in] at 324 mm [12.75 in] Radius

Optional Accessories

- KH47 Reducer
- 2 HP AC Drive Package with Inverter Duty Motor and Commander SK AC Drive (up to 60 cpm)
- Dual Cam and Limit Switch
- Left Hand Cam
- AC brake Motor
- Aluminum dial ring
- Servo motor drive package with precision planetary reducer for applications requiring flexibility or fewer than 6 stations
- Custom dials & tooling plates
- Machined base (see pg. IN-MCH-84)

Maximum Inertia x 1000 kg-cm ² [lb-in ²] for standard package							
Stops	Motion Time [seconds]						
	0.915	1.359	1.521	1.791	2.072	2.217	2.557
6	164 [56]	1106 [378]	1454 [497]	2119 [724]	2923 [999]	3386 [1157]	4594 [1570]
8	497 [170]	2174 [743]	2792 [954]	3971 [1357]	5405 [1847]	6224 [2127]	8372 [2861]
12	1451 [496]	5221 [1784]	6614 [2260]	9262 [3165]	12490 [4268]	14336 [4899]	19168 [6550]
16	2783 [951]	9484 [3241]	11963 [4088]	16672 [5697]	22407 [7657]	25688 [8778]	34280 [11714]
Reducer Ratio							
	29.96	37.97	49.79	58.60	67.80	72.54	83.69

Features

- KH37 Reducer (Ratios from 29.96:1 to 83.69:1)
- 1 HP AC Drive Package with Inverter Duty Motor and IM-pAC AC Drive (up to 60 cpm)
- Double Extended Camshaft (Input Shaft)
- Center Thru Hole (Ø800 mm [Ø31.50 in])
- Cycle Cam and Limit Switch Mounted to Camshaft
- Right Hand Cam

Output Bearing Capacity (loads carried during index):

Radial	159940 N [36350 lbs]
Axial	72829 N [16552 lbs]
Moment	16879 N-m [149376 in-lbs]

Accuracy ±35 arcsec / ±0,038 mm [±.0015 in] at 448 mm [17.65 in] Radius

Repeatability ±9 arcsec / ±0,010 mm [±.0004 in] at 448 mm [17.65 in] Radius

Optional Accessories

- KH47 Reducer
- 2 HP AC Drive Package with Inverter Duty Motor and Commander SK AC Drive (up to 60 cpm)
- Dual Cam and Limit Switch
- Left Hand Cam
- AC brake Motor
- Aluminum dial ring
- Servo motor drive package with precision planetary reducer for applications requiring flexibility or fewer than 6 stations
- Custom dials & tooling plates
- Machined base (see pg. IN-MCH-84)

1550RNG SERIES

Ring Drive Dial Indexer | Dimensions

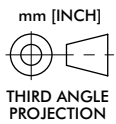
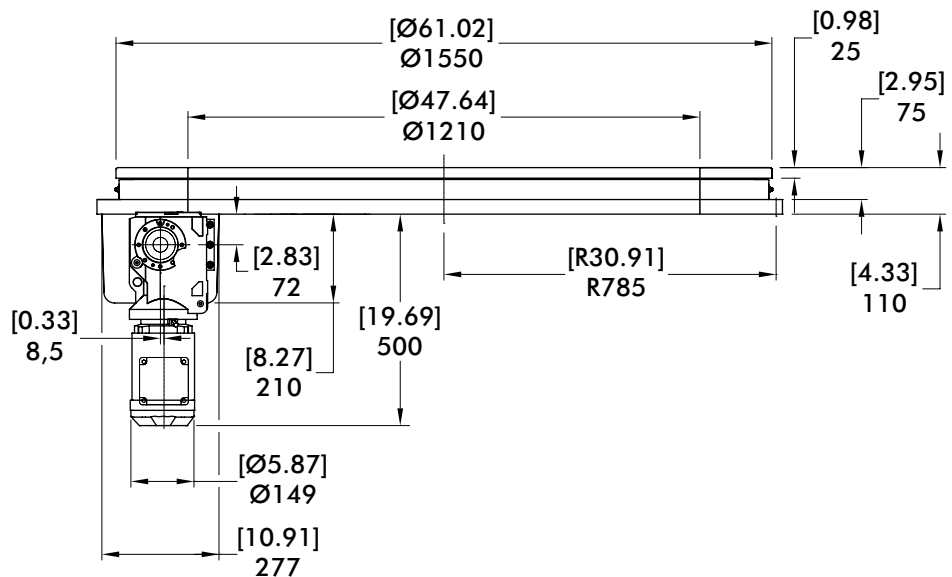
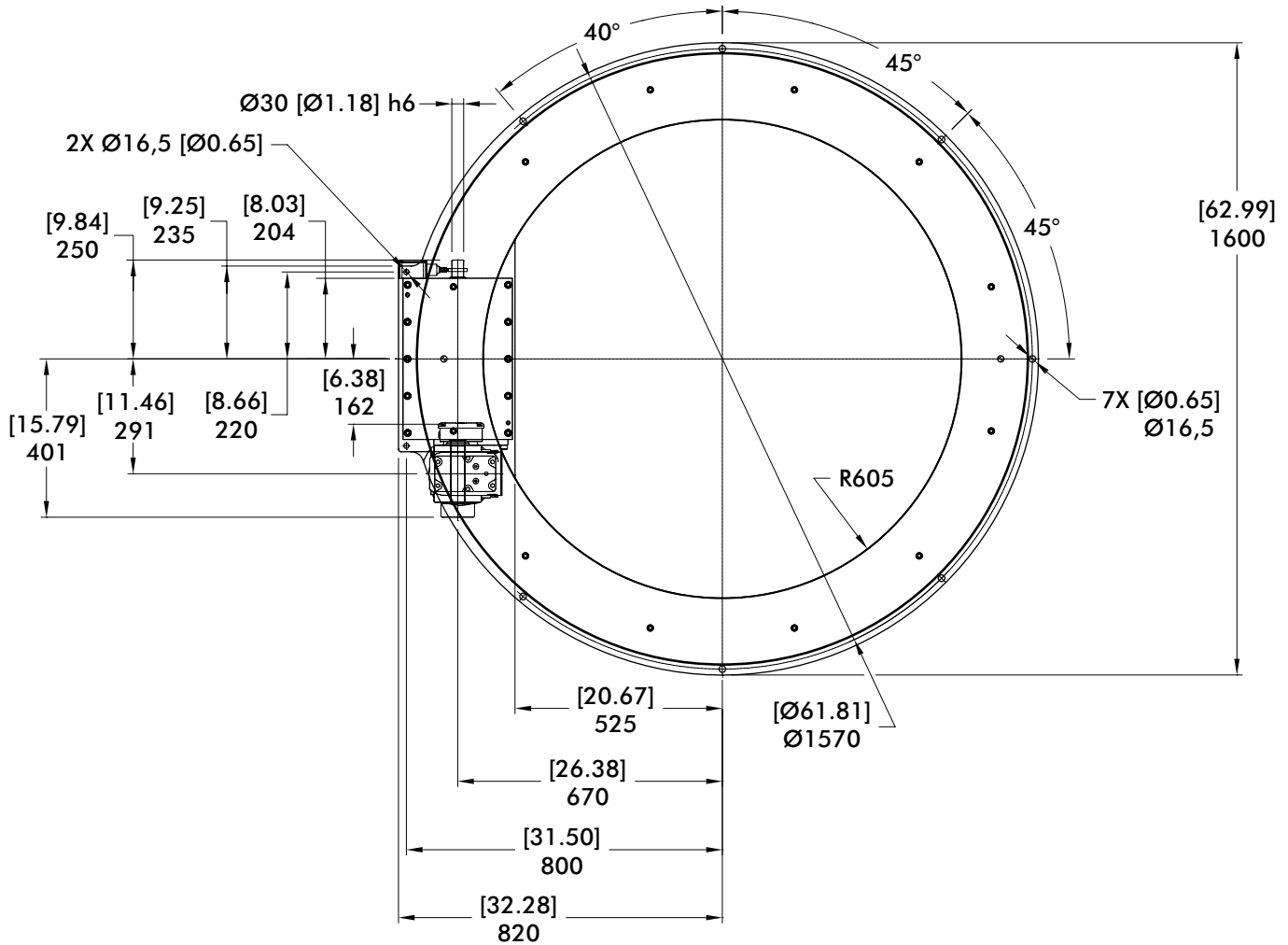

Maximum Inertia x 1000 kg-cm ² [lb-in ²] for standard package							
Stops	Motion Time [seconds]						
	1.210	1.496	1.934	2.134	2.298	2.601	2.776
6	679 [232]	2242 [766]	5063 [1730]	6380 [2180]	7556 [2582]	9964 [3405]	11495 [3928]
8	1984 [678]	4764 [1628]	9780 [3342]	12121 [4142]	14214 [4857]	18495 [6320]	21211 [7248]
12	5718 [1954]	11972 [4091]	23253 [7946]	28527 [9748]	33232 [11356]	42863 [14647]	48979 [16737]
16	10954 [3743]	22071 [7542]	42125 [14395]	51499 [17598]	59868 [20458]	76985 [26307]	87859 [30023]
Reducer Ratio							
	39.61	48.95	63.30	69.84	75.20	85.12	90.86

Features

- KH47 Reducer (Ratios from 39.61:1 to 90.866:1)
- 2 HP AC Drive Package with Inverter Duty Motor and IM-pAC AC Drive (up to 60 cpm)
- Double Extended Camshaft (Input Shaft)
- Center Thru Hole (Ø1210 mm [Ø47.64 in])
- Cycle Cam and Limit Switch Mounted to Camshaft
- Right Hand Cam

Output Bearing Capacity (loads carried during index):

Radial	239052 N [54330 lbs]
Axial	76635 N [17417 lbs]
Moment	25720 N-m [227622 in-lbs]

Accuracy ±25 arcsec / ±0,039 mm [±.0015 in] at 648 mm [25.51 in] Radius

Repeatability ±6 arcsec / ±0,010 mm [±.0004 in] at 648 mm [25.51 in] Radius

Optional Accessories

- Dual Cam and Limit Switch
- Left Hand Cam
- AC brake Motor
- Aluminum dial ring
- Servo motor drive package with precision planetary reducer for applications requiring flexibility or fewer than 6 stations
- Custom dials & tooling plates
- Machined base (see pg. IN-MCH-84)

PRECISION INDEXING SOLUTIONS

Table of Contents

INDEXERS

Servo Positioners



GTB Series
Globoidal (Roller Gear)
Servo Positioner.....IN-SRV-1



RSD Series
Rotary Servo Drives.....IN-SRV-39

Mechanical Indexers



RDM Series
Rotary Index Drive IN-MCH-2



RD Series
Roller Dial Index Drive..... IN-MCH-18



E Series
Heavy-Duty Index Drive IN-MCH-30



RA Series
Right Angle Index Drive IN-MCH-42



RGD/RGS Series
Roller Gear Index Drive IN-MCH-52



P Series
Parallel Shaft/Flange Drive.... IN-MCH-72



RNG Series
Ring Drive Dial Indexer.....IN-MCH-84

OVERLOAD CLUTCHES



Overload Clutches
Output Overload..... IN-CLU-1

CUSTOM CAMS



Custom Cams
Cam Design Solutions IN-CAM-1

CONVEYORS



Rite-Link Series
Thin-Profile.....IN-CNV-1



Precision Link Series
Table-TopIN-CNV-4



Precision Link Series
Heavy-Duty IN-CNV-16

PARTS HANDLERS



LPP Series
Linear Part Handlers IN-PRT-2



RPP Series
Rotary Part Handlers IN-PRT-8

OVERLOAD CLUTCHES

Features | Table of Contents



Features:

CAMCO Output Overload Clutches are designed to protect your indexing equipment from costly downtime due to overload or jam conditions by quickly disengaging the drive system.

Easily Mounted to CAMCO index drives

Single Position reset to maintain accuracy and machine timing

Precision hardened and ground plungers and drive plate

Overload Detector plate provides actuation for overload detector switch

Variety of Models for all applications

Standard & custom torque settings

Table of Contents

Overview	3
D	5
F	6
S	7
F	8
C	9
S-SD	10
FC-SD	11
C-SD	12

OVERLOAD CLUTCHES

Mounting Overview

CAMCO Output Overload Clutches quickly disengage the drive system in overload or jam conditions, protecting indexers from costly downtime. A variety of models are available in standard and custom torque settings. An overload detector plate provides actuation for the overload detector switch, and the clutch's single-position reset function maintains accuracy and machine timing.

- Standard and custom torque settings
- Single-position reset maintains timing, accuracy
- Range of models for all applications
- Rigid, backlash-free design



Indexer Type	Clutch Type
RDM RD	D (Flange Mounted Body)
	F (Flange to Flange)
Roller Gear (RGS / RGD) Parallel (P) Right Angle (RA)	FC (Flange to Shaft)
	FC-SD (Flange to Shaft, Shrink-Disk)
	S (Shaft to Flange)
	S-SD (Shaft to Flange, Shrink-Disk)
	C (Shaft to Shaft Mounting)
	C-SD (Shaft to Shaft, Shrink-Disk)

CAMCO Output Overload Clutches

D Clutch: Flange-Mounted Body

For CAMCO Index Drives with large dial mounting surfaces. The dial plate rests directly on the index drive output flange, providing stability and accuracy.

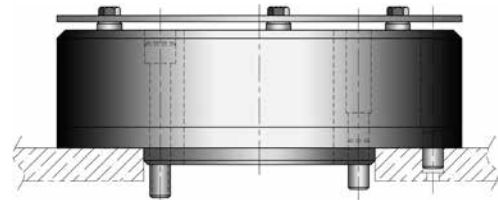

CAMCO Output Overload Clutches

F Clutch: Flange-Mounted Body

F clutches are designed to mount a dial/sprocket/flanged component to a shaft output CAMCO index drive. These clutches will flange mount to the output shaft, providing a rigid, compact, and accurate connection with the driven member.

F clutches may be mounted in two positions, "A" (right, top) or "B" (right, bottom). Mounting "B" provides greater rigidity and overhung loading and should be used whenever high loads are exerted on driven members.

A Mounting

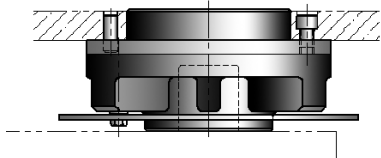

B Mounting

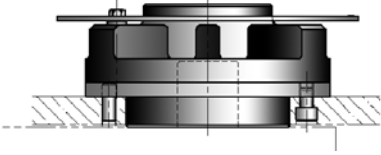

S & S-SD Clutch: Shaft to Flange

S clutches are designed to mount on CAMCO index drives without output flanges. The combination of key and clamped hub design provides a rigid and backlash-free connection.

S clutches may be mounted two positions, "A" or "B." Mounting "B" provides greater rigidity and overhung loading and should be used whenever high loads are exerted on driven members.

The S-SD clutch employs a shrink disk to connect to the shaft.

A Mounting

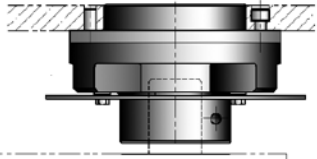

B Mounting

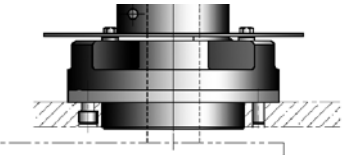

FC & FC-SD Clutch: Flange to Shaft

FC clutches are designed to mount on CAMCO index drives with flanged output shafts. These clutches will flange mount to the output shaft, providing a rigid, compact and accurate connection. The FC-SD clutch employs a shrink disk to connect to the shaft.

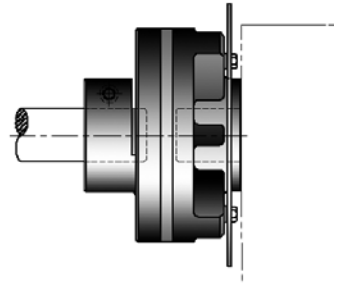

C Clutch: Shaft to Shaft

C clutches are designed to mount on CAMCO index drives without output flanges. These clutches are used whenever a positive connection is required between two shafts. The C-SD clutch employs shrink disks at both ends to connect to the shafts.

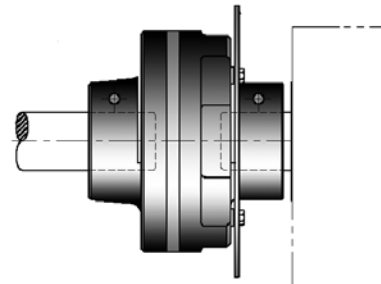

D TYPE FLANGE-MOUNTED BODY

Overload Clutches | Dimensions and Technical Information

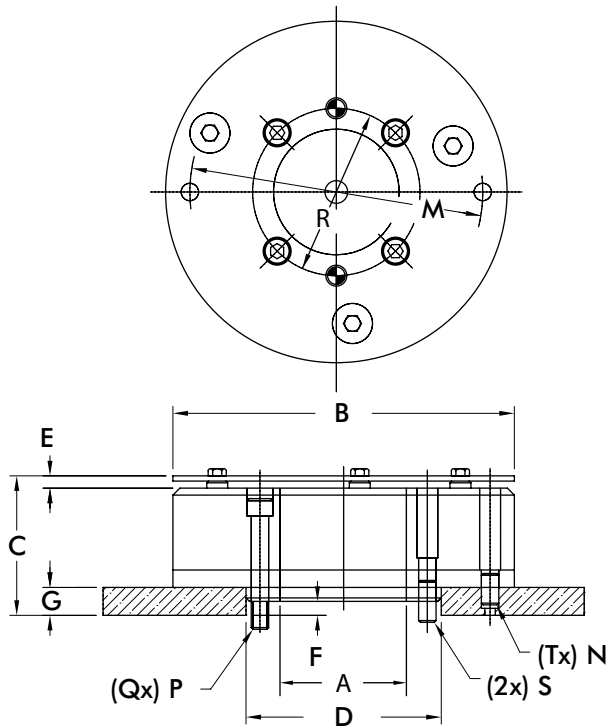

"D" Type clutches are designed to mount on CAMCO Index Drives with large dial mounting surfaces. The dial plate rests directly on the index drive output flange, providing stability and accuracy.

D Type Dimensions

Model	A	B	C	D	E	F	G	M	N	P	Q	R	S	T
2.8D	1.00	5.12	2.50	2.500	0.22	0.250	0.500	4.250	0.312	.312-18	4	2.00	0.31	2
4.0D	2.25	6.12	2.50	3.500	0.22	0.250	0.500	5.250	0.312	.312-18	4	3.00	0.31	2
7.8D	3.41	8.50	2.88	5.000	0.25	0.188	0.750	6.750	0.500	.500-20	4	4.25	0.50	2
18D	2.62	10.25	4.53	5.000	0.31	0.188	1.000	8.250	0.625	.500-20	4	4.25	0.50	2
31D	5.25	14.50	4.03	9.000	0.34	-	1.000	11.750	0.750	.500-20	6	8.25	0.50	4
32D	5.25	14.50	4.03	9.000	0.34	-	1.000	11.750	0.750	.500-13	6	8.25	0.50	4
33D (mm)	133	368	102	228.6	8.4***	-	25	298.5	20	M12	6	210	12	4
61D	7.25	18.38	5.40	11.000	0.34	-	1.250	16.000	0.750	.625-11	8	10.00	.625 (4)	4

* Dimension increases .06 during overload

** Dimension increases .09 during overload

*** Dimension increases .12 during overload

D Type Specifications

Model	Internal Inertia	Torque Setting	Index Drive
2.8D	29	400 480 700 850 1100 1300 1800 2200 3100	425RD
4.0D	69	420 620 750 1150 1750 2950 4000	601RDM
7.8D	266	1400 1700 2600 3200 4200 5000 7200 10000	902RDM 663RAD 900RAD
18D	743	5000 7000 7800 10,000 13000 15000 20000 25000	900RAD
31D	2910	8500 13000 20000 31000	1200RAD
32D	2910	8500 13000 20000 31000	1305RDM
33D	2910	8500 13000 20000 25500	1100RDM
61D	4900	23000 36000 44000 50000 60000	1800RDM

F TYPE SHAFT TO FLANGE MOUNTING

Overload Clutches | Dimensions and Technical Information

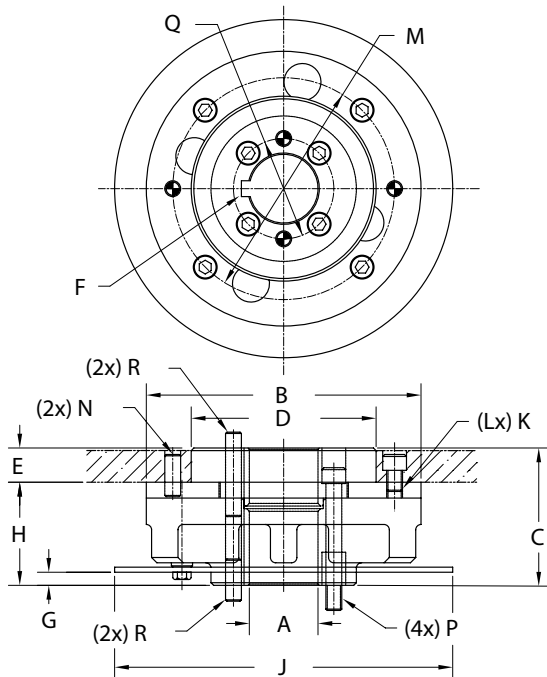

IMC "F" type clutches are designed to mount on IMC index drives. These clutches will flange mount to the output shaft, providing a rigid, compact, and accurate connection with the driven member.

F Type Dimensions

Model	A	B	C	D	E	F	G	H	J	K	L	M	N	P	Q	R
.39F	0.625	3.38	2.19	2.375	0.41	0.1875	.22†	1.78	4.75	10-32	4	2.875	0.25	10-32	1.25	0.25
2.3F	1.000*	5.12	2.78	3.5	0.56	0.25	.22†	2.22	6.5	5/16-24	4	4.25	0.312	5/16-24	2	0.31
6.0F	1.625	6.5	3.25	4.375	0.81	0.375	.31††	2.44	8	3/8-24	4	5.25	0.375	3/8-24	2.38	0.38
11F	2	8.5	3.72	5.75	0.81	0.5	.38††	2.91	10	3/8-24	4	6.75	0.5	3/8-24	3.25	0.5
25F	2.75	10.25	4.97	7.125	1.06	0.625	.38†††	3.91	12	1/2-13	6	8.25	0.625	1/2-20	4.25	0.63

* Also 1.250

† Dimension decreases .06 during overload
 †† Dimension decreases .09 during overload
 ††† Dimension decreases .12 during overload
 †††† Dimension decreases 1.5 mm during overload

F Type Specifications

Model	Internal Inertia	Torque Setting	Index Drive
.39F	5	160 210 270 320 390	250P
2.3F	32	400 600 700 850 1000 1300 1800 2000 230	387P 350RGS/RGD 400RA
6.0F	87	670 825 1100 1400 1700 2000 2300 2 500 3000 3800 4000 5000 6000	512P 512RA
11F	340	2300 4000 6000 8500 11000	662P 662RA
25F	842	5000 7000 10000 13000 15000 20000 25000	900P

S TYPE SHAFT TO FLANGE MOUNTING SERIES

Overload Clutches | Dimensions and Technical Information

IMC "S" type clutches are designed to mount on CAMCO index drives without output flanges. The combination of key and clamped hub design provides a rigid and backlash-free connection.

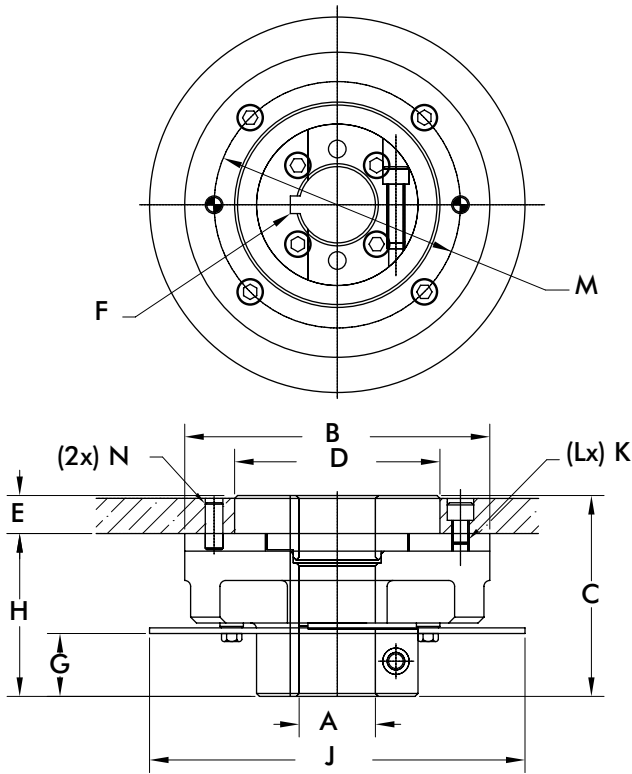

S Type Dimensions

Model	A	B	C	D	E	F	G	H	J	K	L	M	N
.39S	0.6250	3.38	2.63	2.375	0.40	0.187	.66†	2.22	4.75	10-32	4	2.88	0.250
2.3S	1.0000**	5.12	3.31	3.500	0.56	0.250	.75†	2.75	6.50	5/16-24	4	4.25	0.312
6.0S	1.6250	6.50	4.28	4.375	0.81	0.375	1.34††	3.47	8.00	3/8-24	4	5.25	0.375
11S	2.0000	8.50	5.00	5.750	0.81	0.500	1.69††	4.19	10.00	3/8-24	4	6.75	0.500
25S	2.5000	10.25	6.25	7.125	1.06	0.625	1.66†††	5.19	12.00	1/2-13	6	8.25	0.625

* Dimensions in millimeters

** Also 1.2500

† Dimension decreases .06 during overload

†† Dimension decreases .09 during overload

††† Dimension decreases .12 during overload

†††† Dimension decreases 1.5 mm during overload

S Type Specifications

Model	Internal Inertia	Torque Setting	Index Drive
.39S	5	160 210 270 320 390	250P
2.3S	31	400 600 700 850 1000 1300 1800 2000 2300	387P 350RGS/RGD 400RA
6.0S	83	670 825 1100 1400 1700 2000 2300 2500 3000 3800 4000 5000 6000	512P 512RA
11S	320	2300 4000 6000 8500 11000	500RGD/RGS 662RA 662P
25S	803	5000 7000 10000 13000 15000 20000 25000	700RGS

FC TYPE FLANGE TO SHAFT MOUNTING SERIES

Overload Clutches | Dimensions and Technical Information

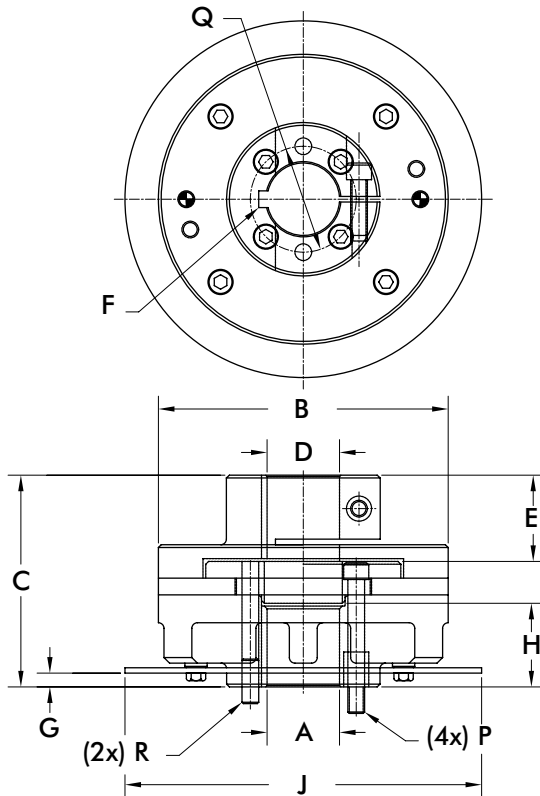

"FC" type clutches are designed to mount on CAMCO index drives. These clutches will flange mount to the output shaft, providing a rigid, compact and accurate connection.

FC Type Dimensions

Model	A	B	C	D	E	F	G	H	J	P	Q	R
.39FC	0.6250	3.38	3.03	0.625	1.06	0.187	.22†	1.41	4.75	10-32	1.25	0.25
2.3FC	1.0000**	5.12	3.81	1.000	1.28	0.250	.22†	1.75	6.50	5/16-24	2.00	0.31
6.0FC	1.6250	6.50	4.75	1.625	1.94	0.375	.31††	1.88	8.00	3/8-24	2.38	0.38
11FC	2.0000	8.50	5.72	2.000	2.38	0.500	.38††	2.25	10.00	3/8-24	3.25	0.38

* Dimensions in millimeters

** Also 1.2500

† Dimension decreases .06 during overload

†† Dimension decreases .09 during overload

††† Dimension decreases .12 during overload

†††† Dimension decreases 1.5 mm during overload

FC Type Specifications

Model	Internal Inertia	Torque Setting	Index Drive
.39FC	7	160 210 270 320 390	250P
2.3FC	43	400 600 700 850 1000 1300 1800 2000 2300	387P 350RGS/RGD 400RA
6.0FC	118	670 825 1100 1400 1700 2000 2300 2500 3000 3800 4000 5000 6000	512P 512RA
11FC	456	2300 4000 6000 8500 11000	662P 662RA

C TYPE SHAFT TO SHAFT MOUNTING SERIES

Overload Clutches | Dimensions and Technical Information

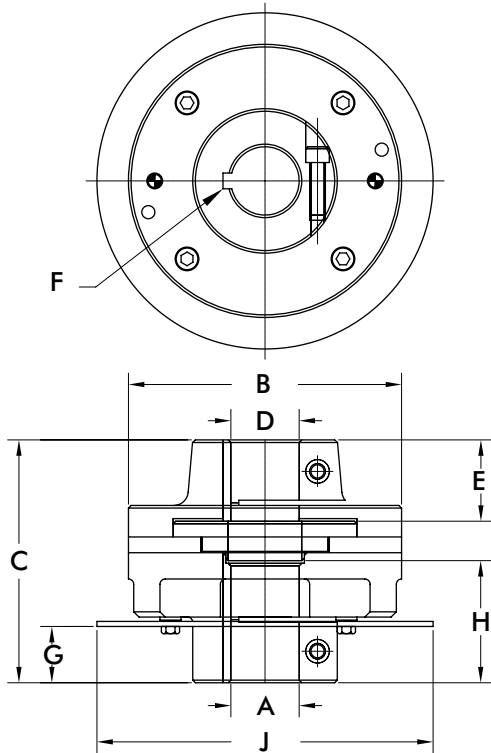

“C” type clutches are designed to mount on CAMCO index drives without output flanges. These clutches are used whenever a positive connection is required between two shafts.

C Type Dimensions

Model	A	B	C	D	E	F	G	H	J	P	Q	R
.39C	0.6250	3.38	3.03	0.625	1.06	0.187	.22†	1.41	4.75	10-32	1.25	0.25
2.3C	1.0000**	5.12	3.81	1.000	1.28	0.250	.22†	1.75	6.50	5/16-24	2.00	0.31
6.0C	1.6250	6.50	4.75	1.625	1.94	0.375	.31††	1.88	8.00	3/8-24	2.38	0.38
11C	2.0000	8.50	5.72	2.000	2.38	0.500	.38††	2.25	10.00	3/8-24	3.25	0.38

* Dimensions in millimeters
 ** Also 1.2500

† Dimension decreases .06 during overload
 †† Dimension decreases .09 during overload
 ††† Dimension decreases .12 during overload
 †††† Dimension decreases 1.5 mm during overload

C Type Specifications

Model	Internal Inertia	Torque Setting	Index Drive
.39C	7	160 210 270 320 390	250P
2.3C	44	400 600 700 850 1000 1300 1800 2000 2300	387P 350RGS/RGD 400RA
6.0C	122	670 825 1100 1400 1700 2000 2300 2500 3000 3800 4000 5000 6000	512P 512RA
11C	476	2300 4000 6000 8500 11000	500RGD/RGS 662P

S-SD TYPE SHAFT TO FLANGE, SHRINK-DISK MOUNTING SERIES

Overload Clutches | Dimensions and Technical Information

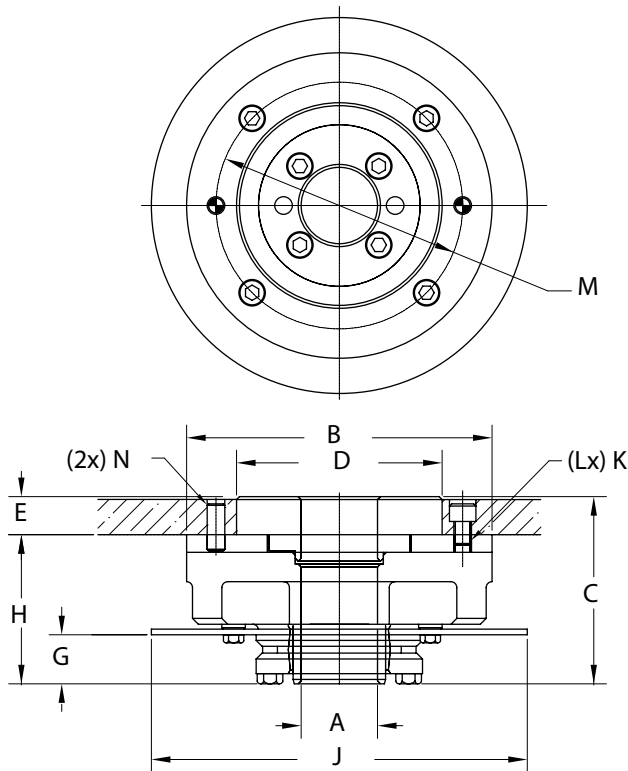

"S-SD" type clutches are designed to mount on CAMCO index drives without output flanges. The shrink disk design converts clamp loads from multiple high strength locking screws to radial gripping force through the use of circular wedges, providing the highest capacity mechanical interference connection available.

S-SD Type Dimensions

Model	A	B	C	D	E	F	G	H	J	K	L	N
.39-SD	0.6250	3.38	2.62	2.375	0.40	.66†	2.22	4.75	10-32	4	2.88	0.250
2.3-SD	1.0000	5.12	3.31	3.500	0.56	.75†	2.75	6.50	5/16-24	4	4.25	0.312
6.0-SD	1.6250	6.50	3.98	4.375	0.81	1.04††	3.17	8.00	3/8-24	4	5.25	0.375
11-SD	2.0000	8.50	4.38	5.750	0.82	1.06††	3.56	10.00	3/8-24	4	6.75	0.500

* Dimensions in millimeters

† Dimension decreases .06 during overload

†† Dimension decreases .09 during overload

††† Dimension decreases .12 during overload

†††† Dimension decreases 1.5 mm during overload

S-SD Type Specifications

Model	Internal Inertia	Torque Setting	Index Drive
.39-SD	5	160 210 270 320 390	250P
2.3-SD	32	400 600 700 850 1000 1300 1800 2000 2300	387P 350RGS/RGD 400RA
6.0-SD	87	670 825 1100 1400 1700 2000 2300 2500 3000 3800 4000 5000 6000	512P 512RA
11-SD	340	2300 4000 6000 8500 11000	500RGD/RGS 662P

FC-SD TYPE FLANGE TO SHAFT, SHRINK-DISK MOUNTING SERIES

Overload Clutches | Dimensions and Technical Information

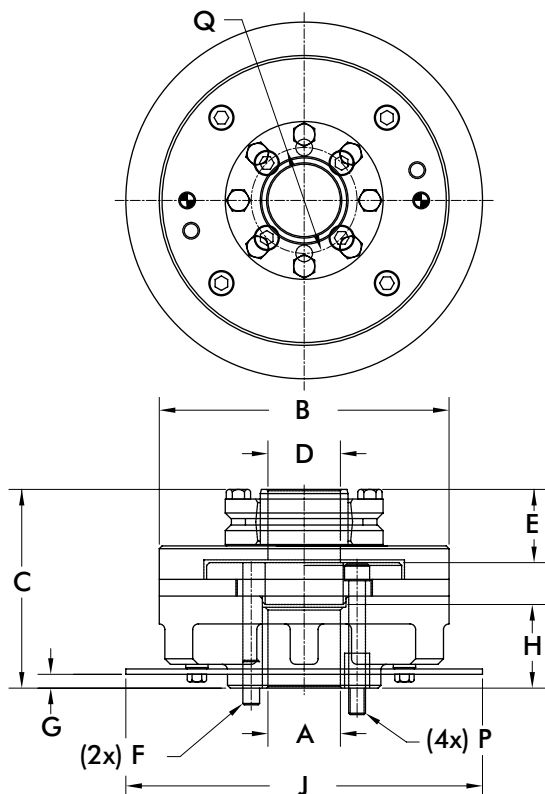

“FC-SD” type clutches are designed to mount on CAMCO index drives with output flanges. The shrink disk design converts clamp loads from multiple high strength locking screws to radial gripping force through the use of circular wedges, providing the highest capacity mechanical interference connection available.

FC-SD Type Dimensions

Model	A	B	C	D	E	F	G	H	J	P	Q
.39FC-SD	0.6250	3.38	3.00	0.625	1.03	0.25	.22†	1.41	4.75	10-32	1.25
2.3FC-SD	1.0000	5.12	3.81	1.000	1.27	0.31	.22†	1.75	6.50	5/16-24	2.00
6.0FC-SD	1.6250	6.50	4.46	1.625	1.64	0.38	.31††	1.88	8.00	3/8-24	2.38
11FC-SD	2.0000	8.50	5.06	2.000	1.75	0.38	.38††	2.25	10.00	3/8-24	3.25

* Dimensions in millimeters

† Dimension decreases .06 during overload

†† Dimension decreases .09 during overload

††† Dimension decreases .12 during overload

†††† Dimension decreases 1.5 mm during overload

FC-SD Type Specifications

Model	Internal Inertia	Torque Setting	Index Drive
.39FC-SD	7	160 210 270 320 390	250P
2.3FC-SD	34	400 600 700 850 1000 1300 1800 2000 2300	387P 350RGS/RGD 400RA
6.0FC-SD	118	670 825 1100 1400 1700 2000 2300 2500 3000 3800 4000 5000 6000	512P 512RA
11FC-SD	456	2300 4000 6000 8500 11000	500RGD/RGS 662P 662RA

C-SD TYPE SHAFT TO SHAFT, SHRINK-DISK MOUNTING SERIES

Overload Clutches | Dimensions and Technical Information

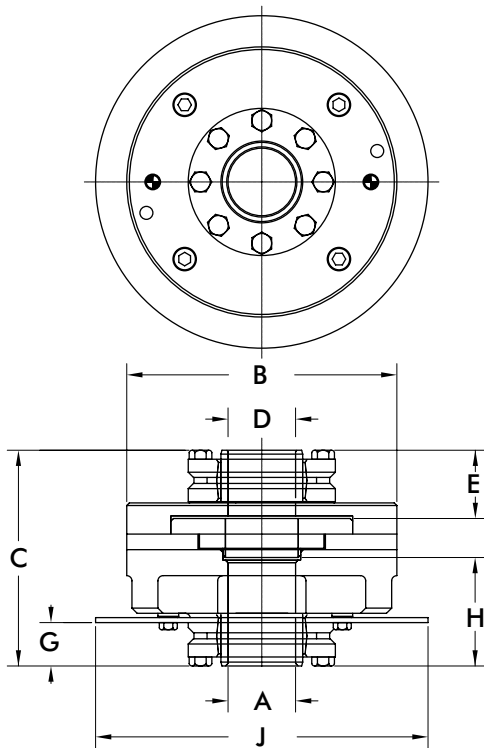

“C-SD” type clutches are designed to mount on CAMCO index drives without output flanges. The shrink disk design converts clamp loads from multiple high strength locking screws to radial gripping force through the use of circular wedges, providing the highest capacity mechanical interference connection available.

C-SD Type Dimensions

Model	A	B	C	D	E	G	H	J
.39C-SD	0.6250	3.38	3.44	0.625	1.03	.66†	1.84	4.75
2.3C-SD	1.0000	5.12	4.34	1.000	1.28	.75†	2.28	6.50
6.0C-SD	1.6250	6.50	5.19	1.625	1.64	1.04††	2.61	8.00
11C-SD	2.0000	8.50	5.75	2.000	1.75	1.06††	2.93	10.00

* Dimensions in millimeters

† Dimension decreases .06 during overload

†† Dimension decreases .09 during overload

††† Dimension decreases .12 during overload

†††† Dimension decreases 1.5 mm during overload

C-SD Type Specifications

Model	Internal Inertia	Torque Setting	Index Drive
.39C-SD	7	160 210 270 320 390	250P
2.3C-SD	44	400 600 700 850 1000 1300 1800 2000 2300	387P 350RGS/RGD 400RA
6.0C-SD	122	670 825 1100 1400 1700 2000 2300 2500 3000 3800 4000 5000 6000	512P 512RA
11C-SD	476	2300 4000 6000 8500 11000	500RGD/RGS 662P 662RA

CUSTOM CAMS

Product Overview







CAMCO Custom Cams serve as an economical alternative to “in house” cam design, engineering and manufacturing. Backed by over 100 years of experience, we offer cams in a comprehensive range of configurations, tolerances and materials.

Our designers employ the most advanced computer technology available for detailed kinematic studies and dynamic analysis. In addition to common dimensional inspection, we perform computerized contour measurements with sophisticated, unique inspection equipment in both 2D and 3D.

Our commitment to applied engineering allows us to respond quickly to complicated manufacturing issues with specialized solutions that are precise, economical and engineered to your exacting specifications. Alternative materials, milling, and grinding techniques are explored to provide the best solution for your application at the most economical price.

To assist in your in-house cam design, you can download Clyde H. Moon’s “Cam Design Manual for Engineers, Designers, and Draftsman” from the DESTACO website, www.destaco.com.

Custom Cams are available in a variety of styles:

<p>Plate Cams Popular, economical design used in low speed applications.</p>	
<p>Globoidal Cams Complex, tapered rib globoidal cams, commonly known as roller gear cams, are the heart of IMC's indexers. Controlled follower preloads increase follower life, speeds and accuracy for the ultimate solution in motion control.</p>	
<p>Face-Grooved Cams Medium speed cams using a groove slightly larger than the follower diameter providing minimal running clearance and reduced backlash.</p>	
<p>Conjugate Cams Dual cams controlling preloaded followers which provide higher speed capabilities and better accuracy.</p>	
<p>Barrel Cams Cylindrical cams which can be provided as an end cam, grooved type with minimal follower clearance or as a ribbed type utilizing preloaded followers for increased life and accuracy.</p>	

RITE-LINK SERIES

Features and Benefits

Right Sized Conveying

The **CAMCO Rite-Link Conveyor** is a thin-profile, preassembled, precision link system offering maintenance free accuracy and durability for industrial conveying applications.

Precision positioning requiring higher precision or speed than roller chain can provide

Material conveying (industrial or medical): for example, narrow cleat or bucket conveyor for constant speed applications. The conveyor can be mounted for either over/under or carousel operation



Features:

Assembly

- Fully designed, assembled and tested for your application
- Can be used in an over/under or carousel configuration

Size

- Slim, compact design with narrow links accommodates oversized tooling
- Easy to integrate
- Servo-friendly for flexible indexing with CAMCO RSD rotary servo drive

Accuracy

- Precision motion from the trusted industry leader
- More accurate and stable than roller chain

Operation

- High operation speeds
- No lubrication needed
- Energy efficient
- Cost Effective

Maximum Load	Units	75RL...	115RL...	150RL...
Max Load per Link	kg [lbm]		4 [8.82]	
Max Overhung Load per Link	N-m [in-lb]		0,57 [5]	

* shipping/clearance dimensions

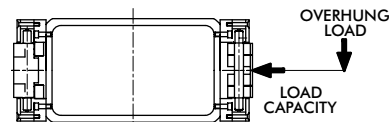
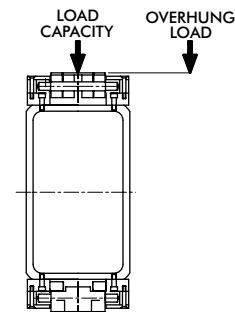

RITE-LINK SERIES

Link Dimensions

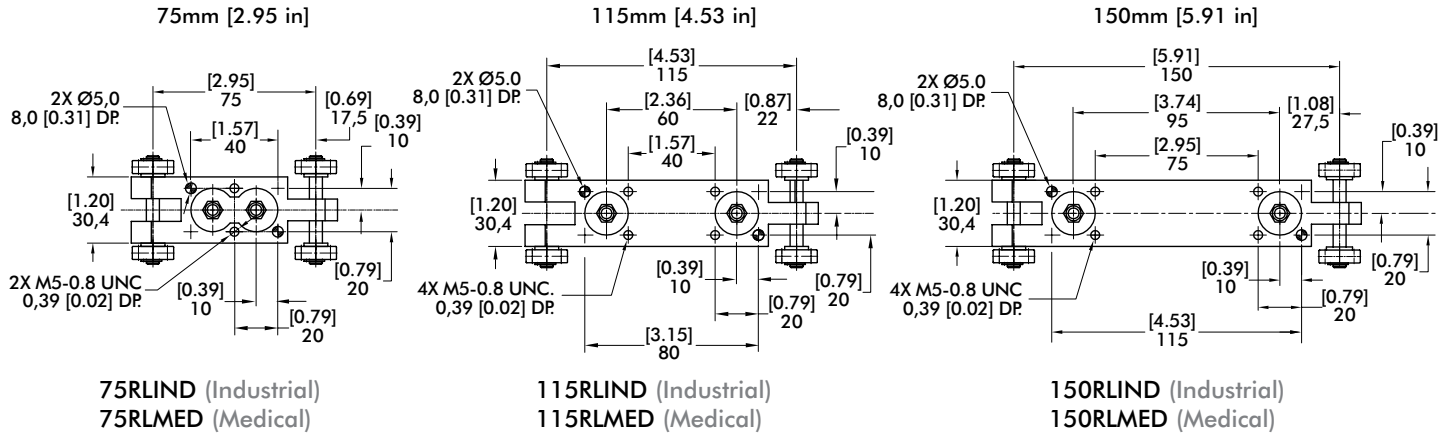

Standard Centers Dimensions

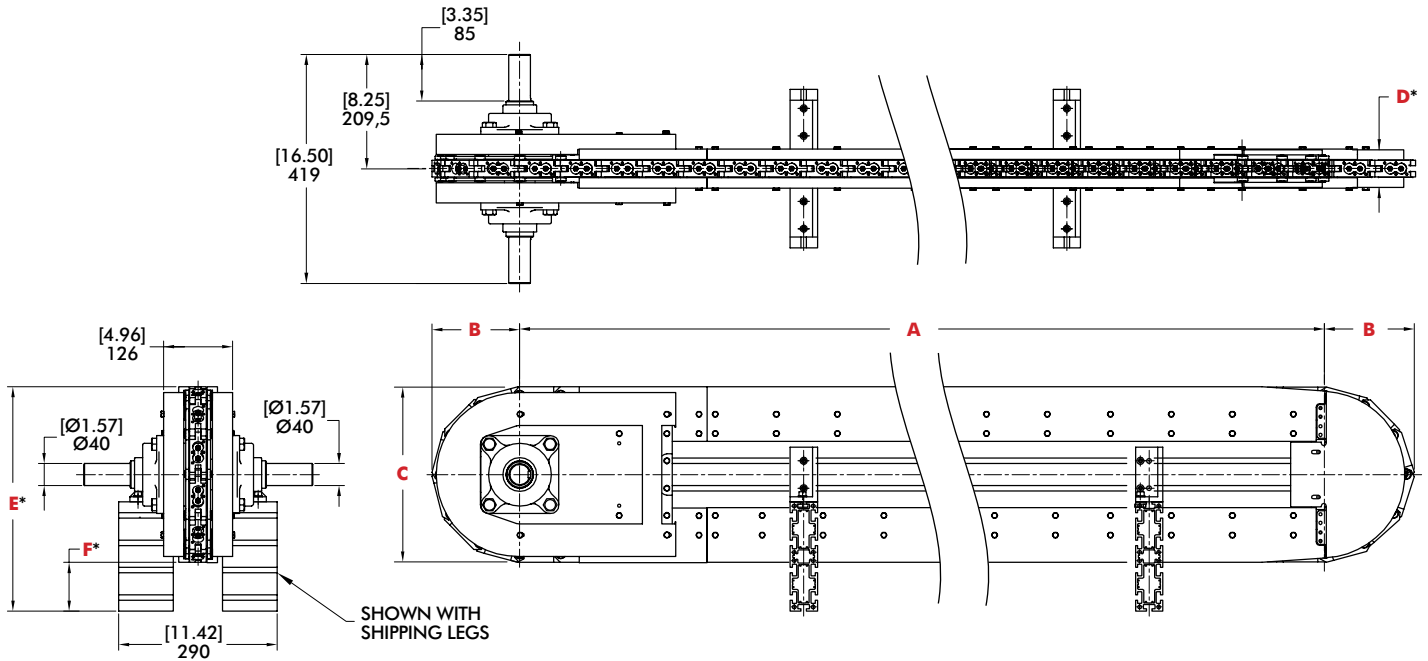

Technical Information

Dimensions	Units	75RL...	115RL...	150RL...
A Standard Center Distances				
Option 1	m [ft]	1,2 [3.94]	1,38 [4.53]	1,2 [3.94]
Option 2		2,1 [6.89]	2,30 [7.55]	2,1 [6.89]
Option 3		3 [9.84]	3,22 [10.56]	3 [9.84]
Option 4		3,9 [12.80]	4,14 [13.58]	3,9 [12.80]
Option 5		4,8 [15.75]	5,06 [16.60]	4,8 [15.75]
B	mm [in]	162,5 [6.40]	166 [6.54]	162,5 [6.40]
C	mm [in]	320 [12.60]	332 [13.07]	332 [13.07]
D*	mm [in]	78,1 [3.07]	78,1 [3.07]	78,1 [3.07]
E*	mm [in]	411 [16.18]	466,2 [18.35]	416 [16.38]
F*	mm [in]	89 [3.50]	133,8 [5.27]	84 [3.31]

* shipping/clearance dimensions

PRECISION INDEXING SOLUTIONS

Table of Contents

INDEXERS

Servo Positioners



GTB Series
Globoidal (Roller Gear)
Servo Positioner.....IN-SRV-1



RSD Series
Rotary Servo Drives.....IN-SRV-39

Mechanical Indexers



RDM Series
Rotary Index Drive IN-MCH-2



RD Series
Roller Dial Index Drive..... IN-MCH-18



E Series
Heavy-Duty Index Drive IN-MCH-30



RA Series
Right Angle Index Drive IN-MCH-42



RGD/RGS Series
Roller Gear Index Drive IN-MCH-52



P Series
Parallel Shaft/Flange Drive.... IN-MCH-72



RNG Series
Ring Drive Dial Indexer.....IN-MCH-84

OVERLOAD CLUTCHES



Overload Clutches
Output Overload..... IN-CLU-1

CUSTOM CAMS



Custom Cams
Cam Design Solutions IN-CAM-1

CONVEYORS



Rite-Link Series
Thin-Profile.....IN-CNV-1



Precision Link Series
Table-TopIN-CNV-4



Precision Link Series
Heavy-Duty IN-CNV-16

PARTS HANDLERS



LPP Series
Linear Part Handlers IN-PRT-2



RPP Series
Rotary Part Handlers IN-PRT-8

TABLE-TOP MODULAR CONVEYORS

Features | How To Order

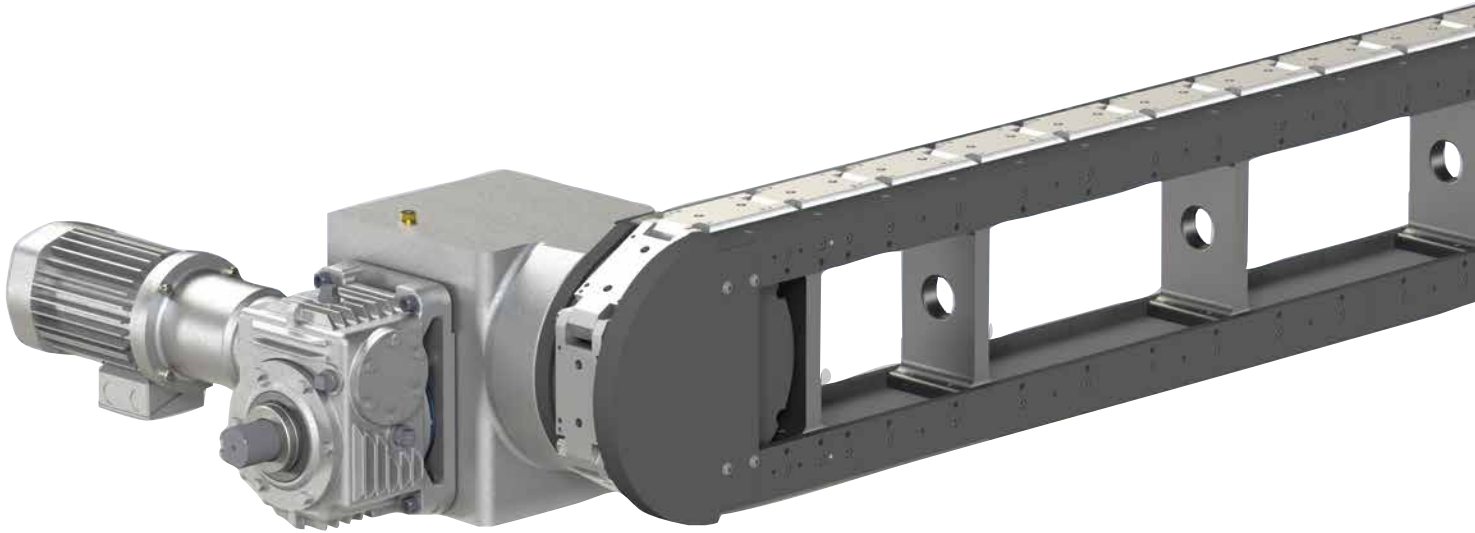

Features:

CAMCO Modular Table Top Precision Link Conveyors are ideal for linear transfer applications with features including:

Modular frame design in fixed increment lengths facilitates quick assembly and delivery.

Table-Top or Base mounted

Available in carousel or over-under style

Precision positioning of parts for assembly or manufacturing processes

High-speed station-to-station parts transfer

Precision links with roller bearing cam followers for smooth transfer and long life.

Link lengths of 3.0", 4.5", and 6.0" meet most application requirements

Open frame design for pass-through of belting, linkages, electric and air supply components.

Optional bases, line shafts & tooling plates

Complete with motorized index drive system including overload protection.

Table of Contents

3.0 Inch	3
4.5 Inch	5
6.0 Inch	7
Conveyor Options	9

3.0 INCH SERIES

Table-Top Modular Conveyors | Dimensions and Configurations

Modular Conveyor (module only)

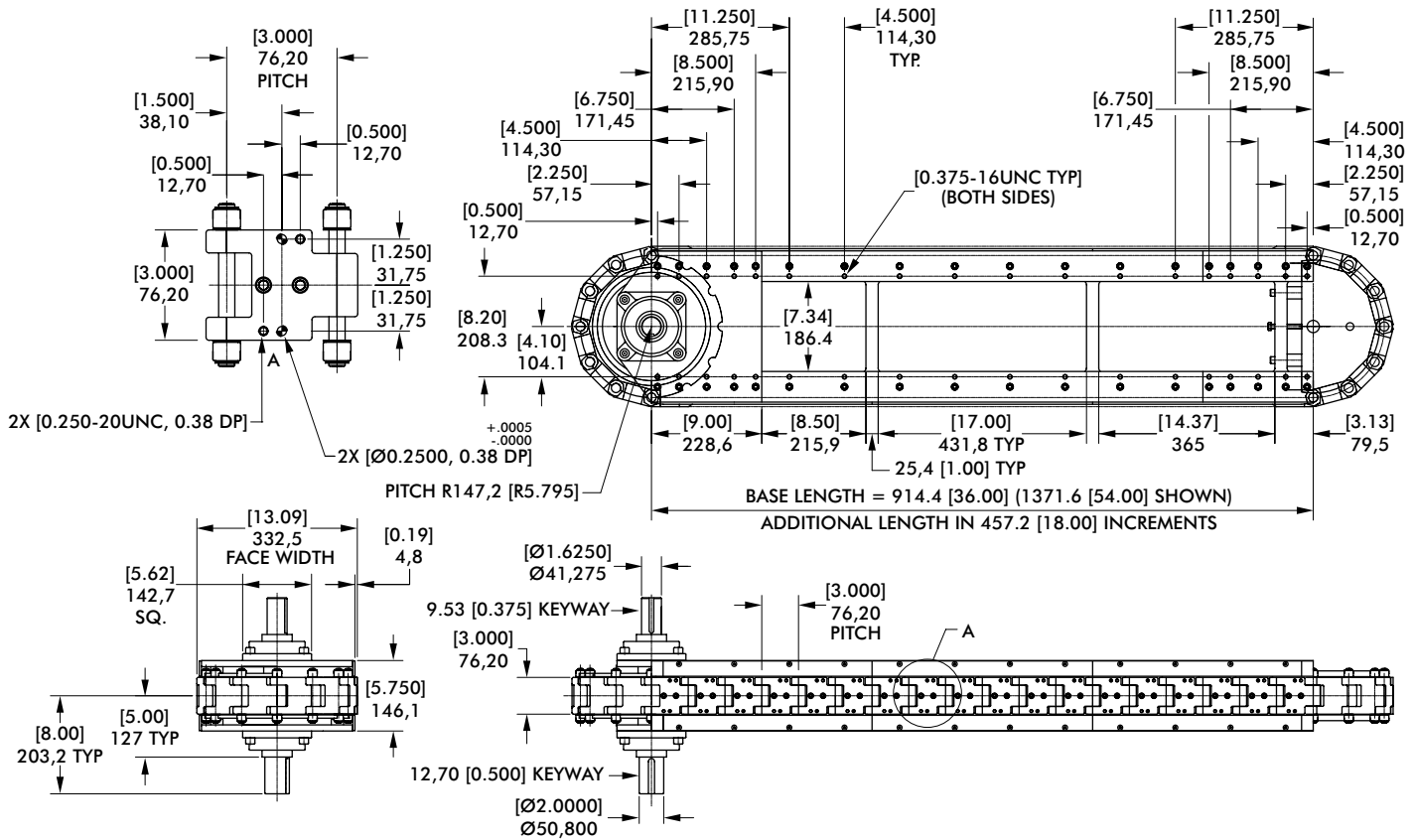

Modular Conveyor (drive package)

Standard Drive Package

- 512RA Index Drive
- R225 Gear Reducer
- 6.0FC-SD Overload Clutch (Shaft Drive)
- 6.0S-SD Overload Clutch (Direct Drive)
- 1 HP high-cycling, performance AC Motor
- IM-pAC Motor Control

Heavy-Duty Drive Package

- 662RA Index Drive
- 7300C Gear Reducer
- 11FC-SD Overload Clutch (Shaft Drive)
- 6.0-SD Overload Clutch (Direct Drive)
- 1 HP high-cycling, performance AC Motor
- IM-pAC Motor Control

Index Distance mm [in]	Indexer Stops
76,2 [3.00]	12
152,4 [6.00]	6
228,6 [9.00]	4
304,8 [12.00]	3

Direct Drive Carousel

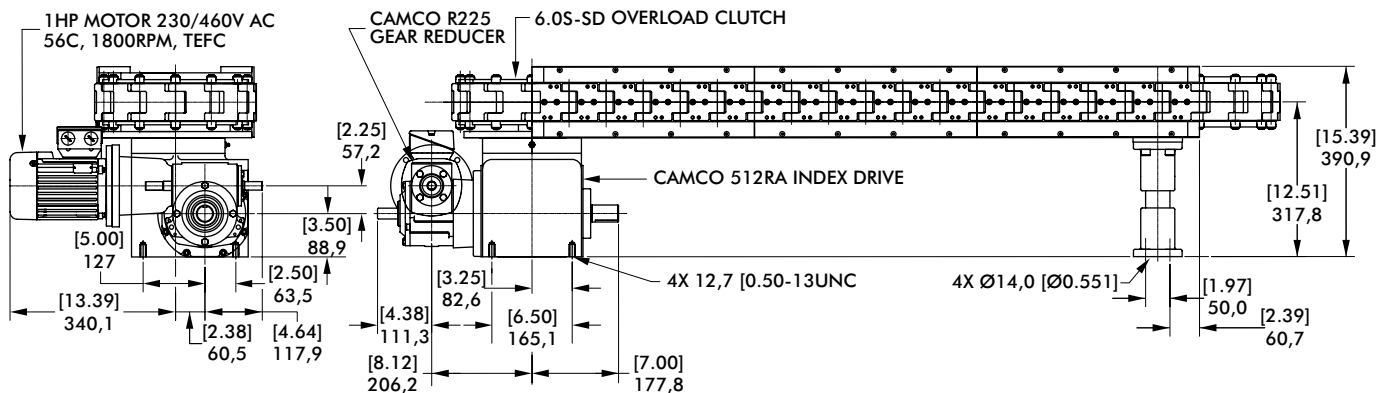

3.0 INCH SERIES

Table-Top Modular Conveyors | Configurations

Shaft Drive Carousel

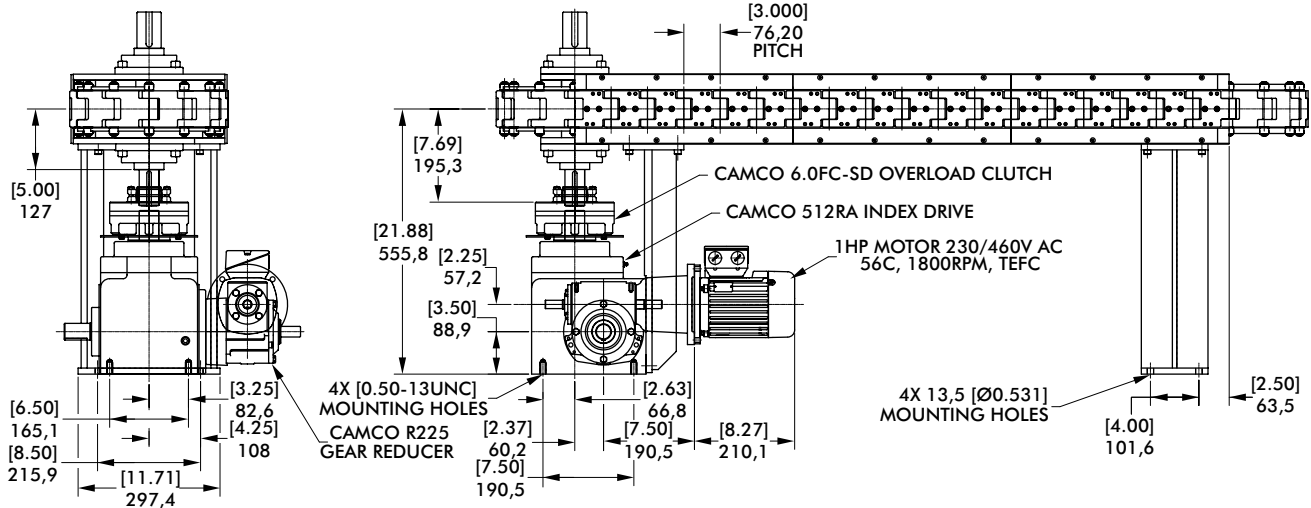

Shaft Drive Over/Under

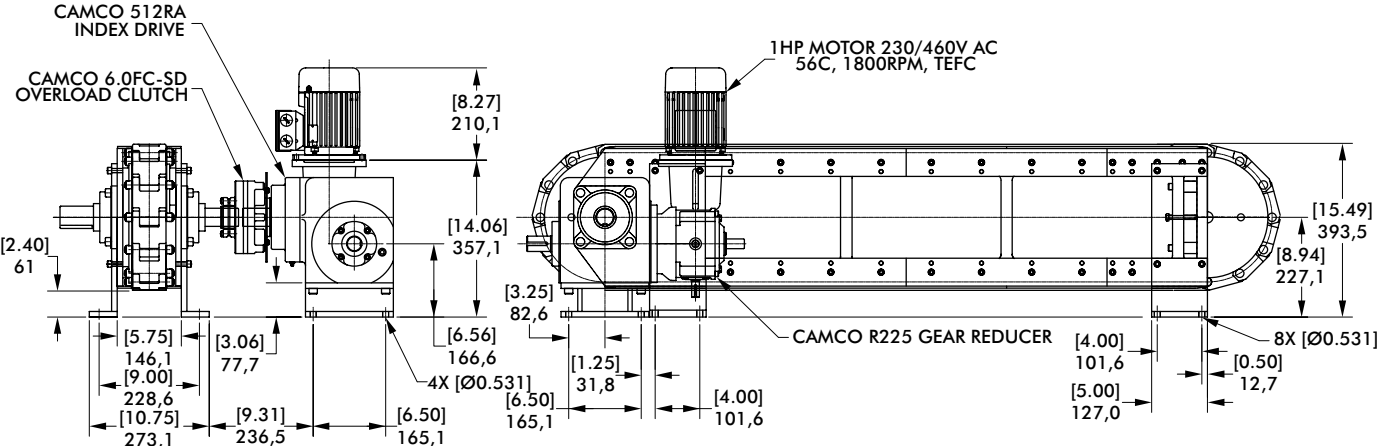

Direct Drive Over/Under

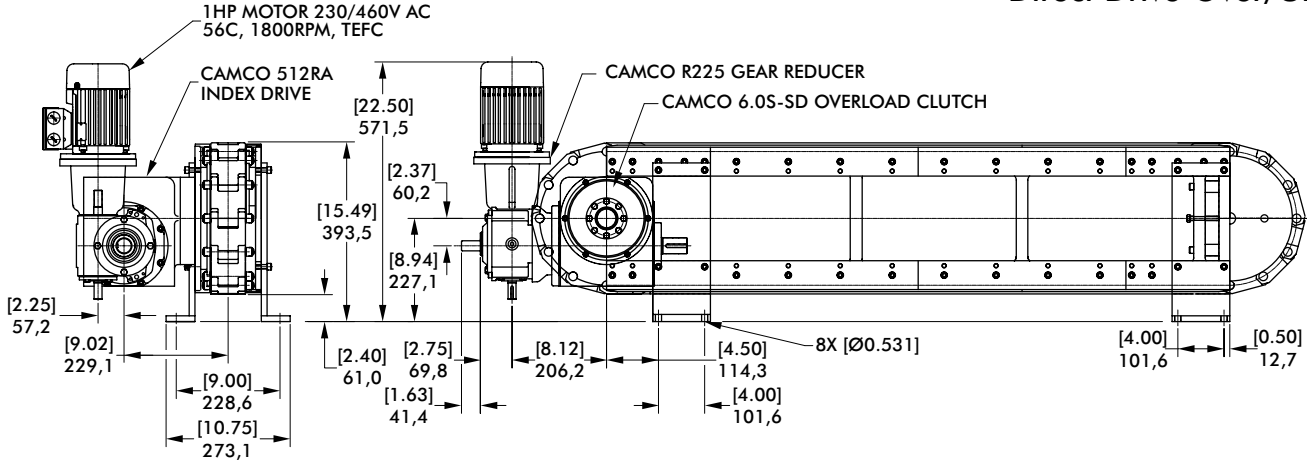

4.5 INCH SERIES

Table-Top Modular Conveyors | Dimensions and Configurations

Modular Conveyor (module only)

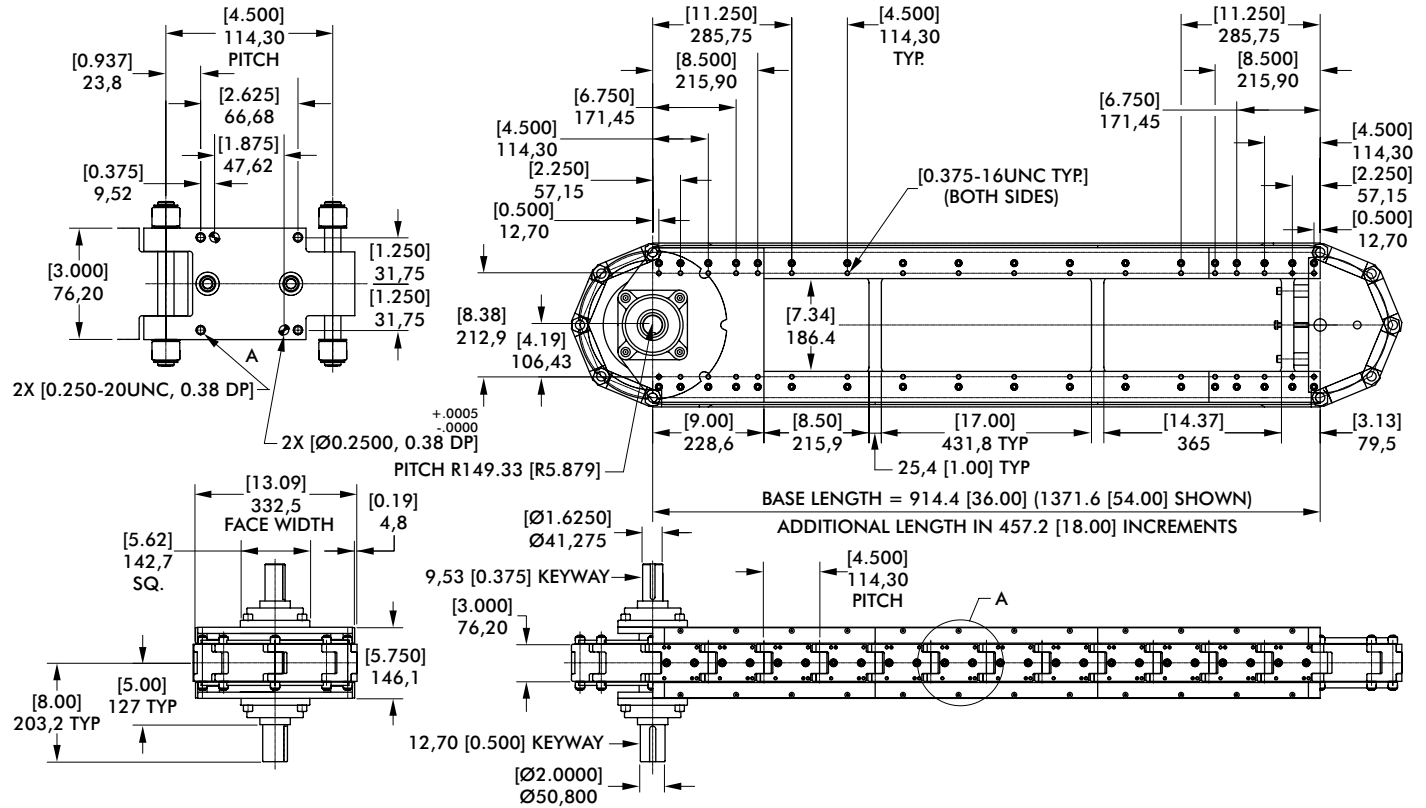

Modular Conveyor (drive package)

Standard Drive Package

- 512RA Index Drive
- R225 Gear Reducer
- 6.0FC-SD Overload Clutch (Shaft Drive)
- 6.0S-SD Overload Clutch (Direct Drive)
- 1 HP high-cycling, performance AC Motor
- IM-pAC Motor Control

Heavy-Duty Drive Package

- 662RA Index Drive
- 7300C Gear Reducer
- 11FC-SD Overload Clutch (Shaft Drive)
- 6.0-SD Overload Clutch (Direct Drive)
- 1 HP high-cycling, performance AC Motor
- IM-pAC Motor Control

Index Distance mm [in]	Indexer Stops
76,2 [4.50]	8
228,6 [9.00]	4
457,2 [18.00]	2

Direct Drive Carousel

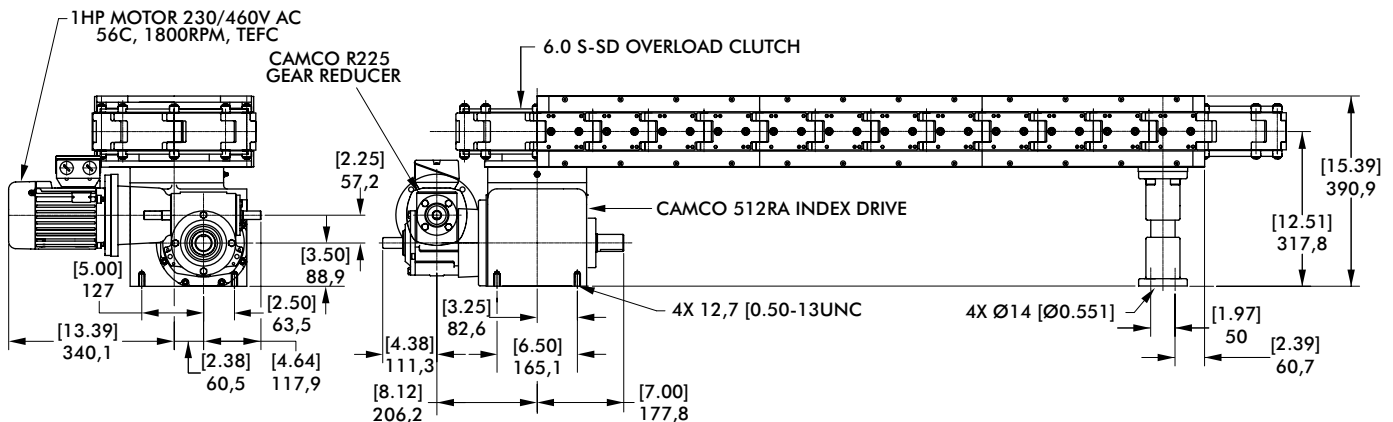

4.5 INCH SERIES

Table-Top Modular Conveyors | Configurations

Shaft Drive Carousel

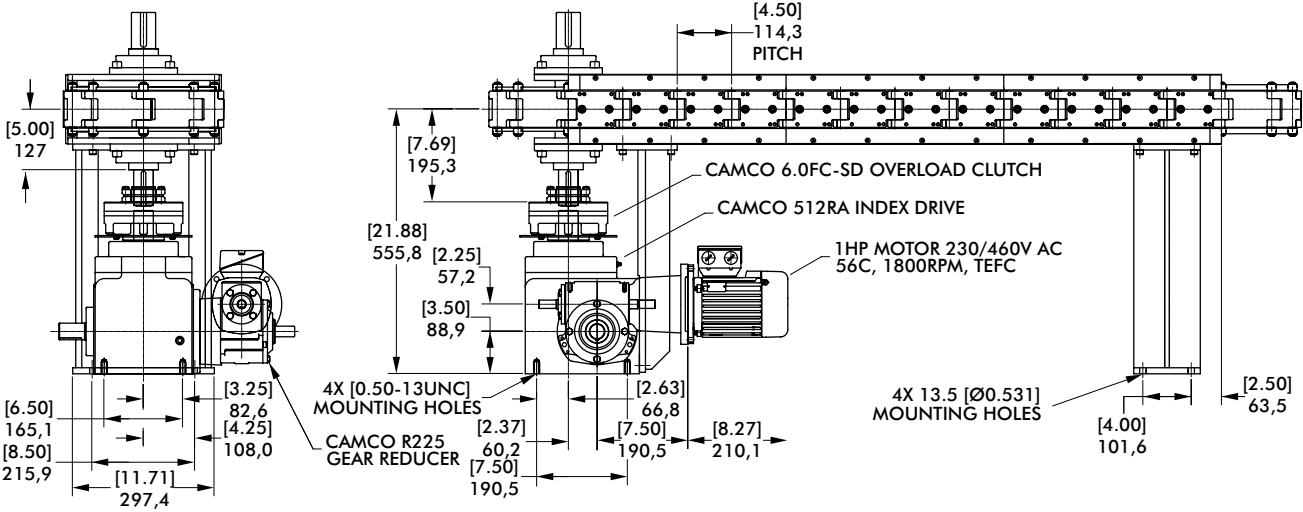

Shaft Drive Over/Under

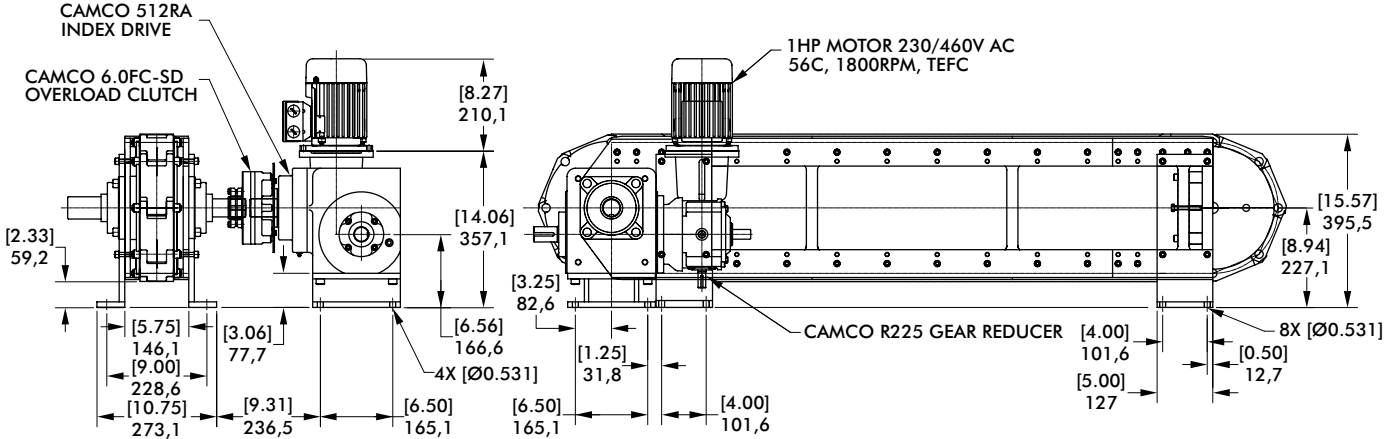

Direct Drive Over/Under

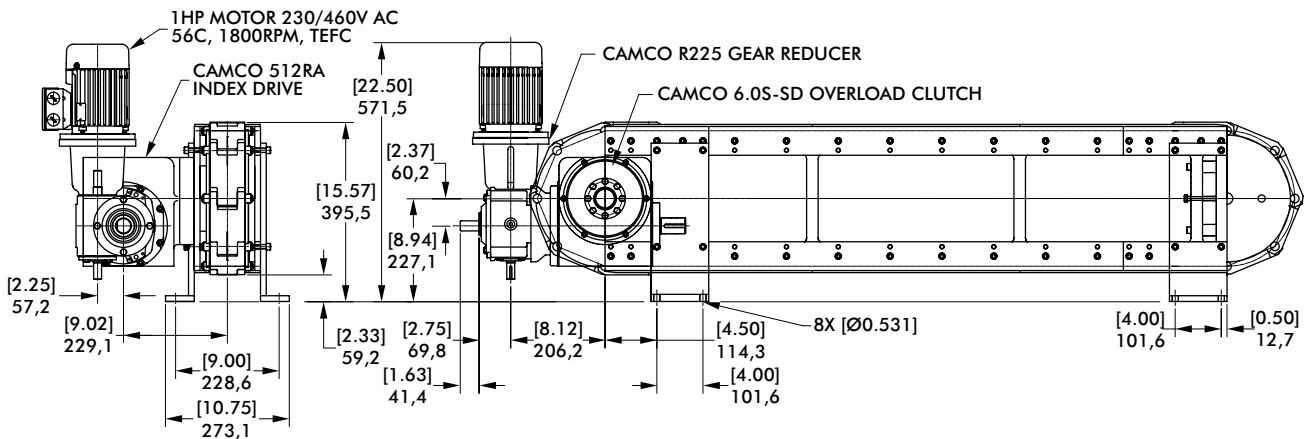

6.0 INCH SERIES

Table-Top Modular Conveyors | Dimensions and Configurations

Modular Conveyor (module only)

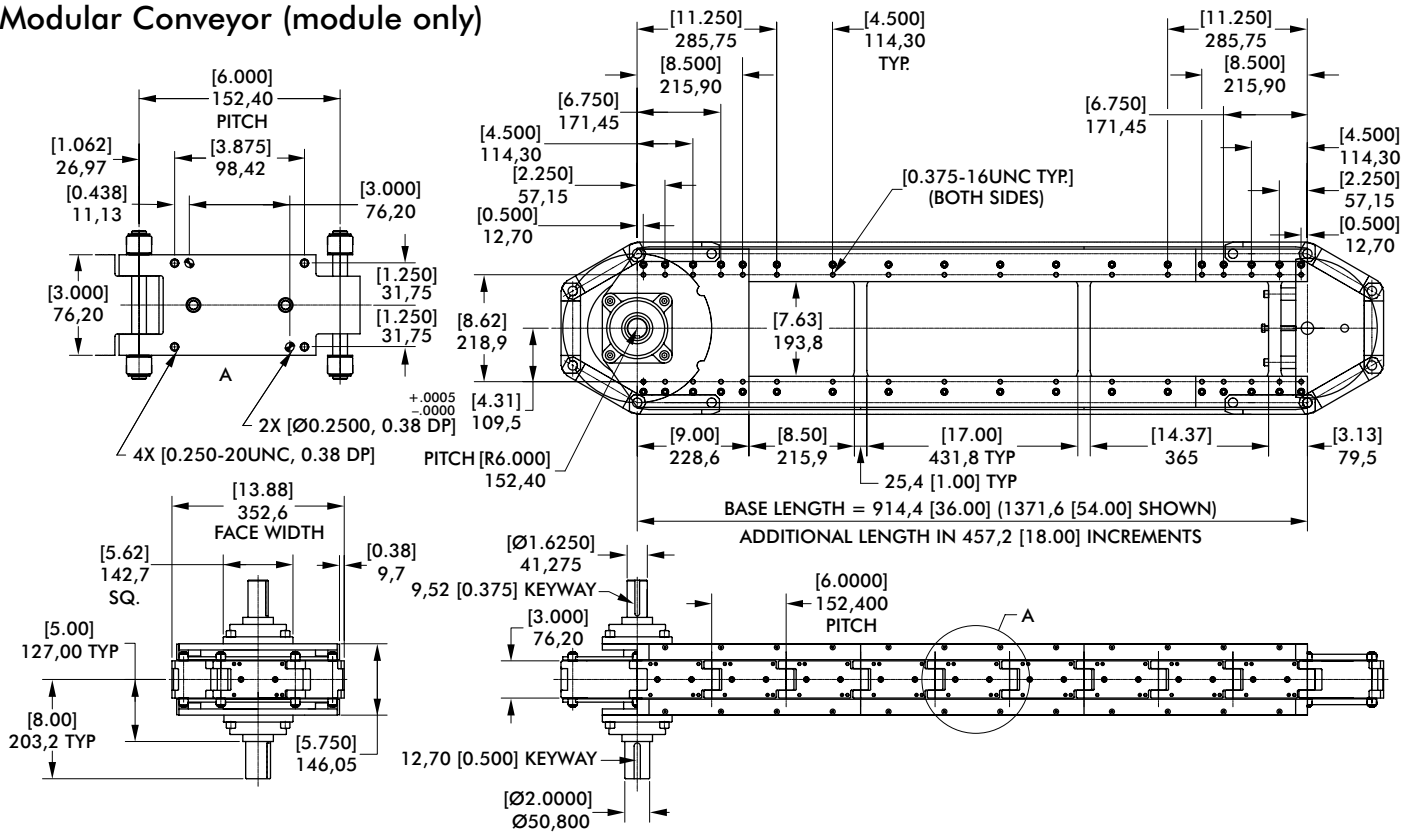

Modular Conveyor (drive package)

Standard Drive Package

- 662RA Index Drive
- 7300C Gear Reducer
- 11FC-SD Overload Clutch (Shaft Drive)
- 6.0S-SD Overload Clutch (Direct Drive)
- 1 HP high-cycling, performance AC Motor
- IM-pAC Motor Control

Heavy-Duty Drive Package

- 800RD Index Drive
- 7300C Gear Reducer
- 25FC-SD Overload Clutch
- 1 HP high-cycling, performance AC Motor
- IM-pAC Motor Control

Index Distance mm [in]	Indexer Stops
152,4 [6.00]	6
304,8 [12.00]	3
457,2 [18.00]	2

Direct Drive Carousel

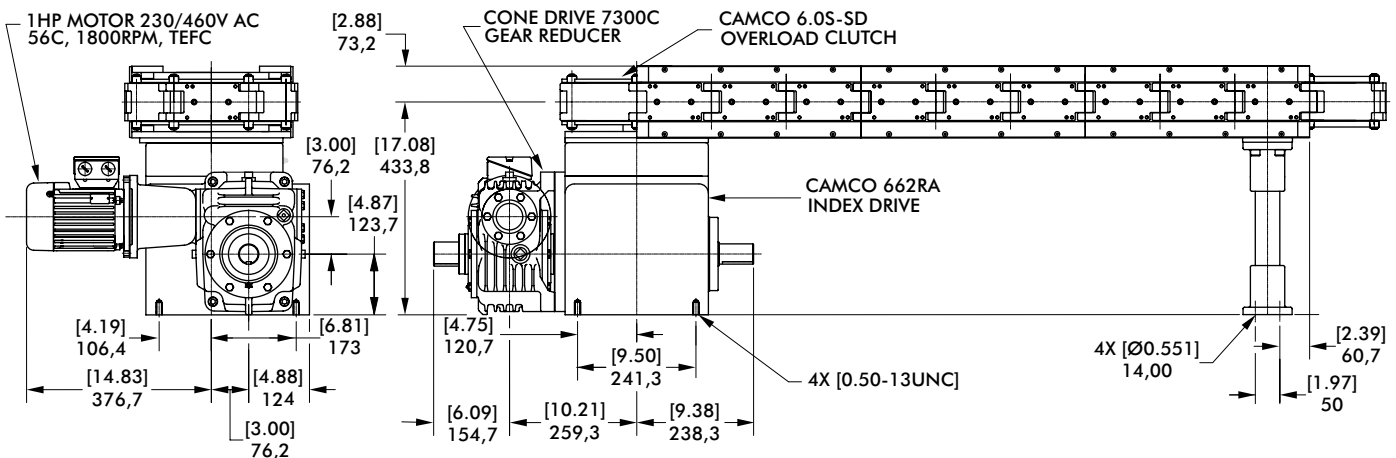

6.0 INCH SERIES

Table-Top Modular Conveyors | Configurations

Shaft Drive Carousel

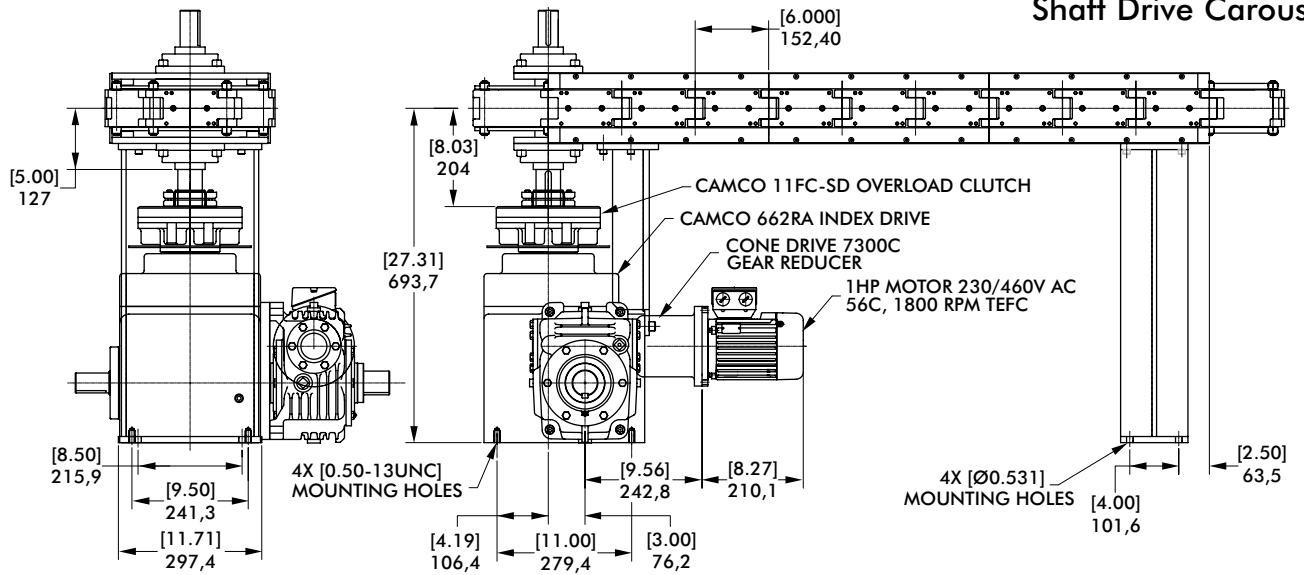

Shaft Drive Over/Under

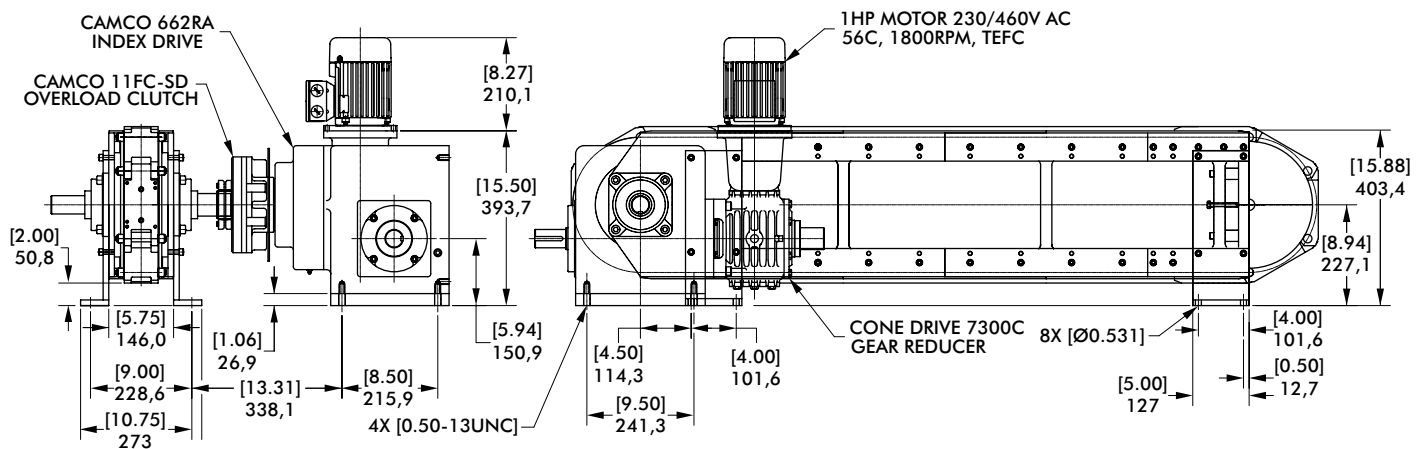

Direct Drive Over/Under

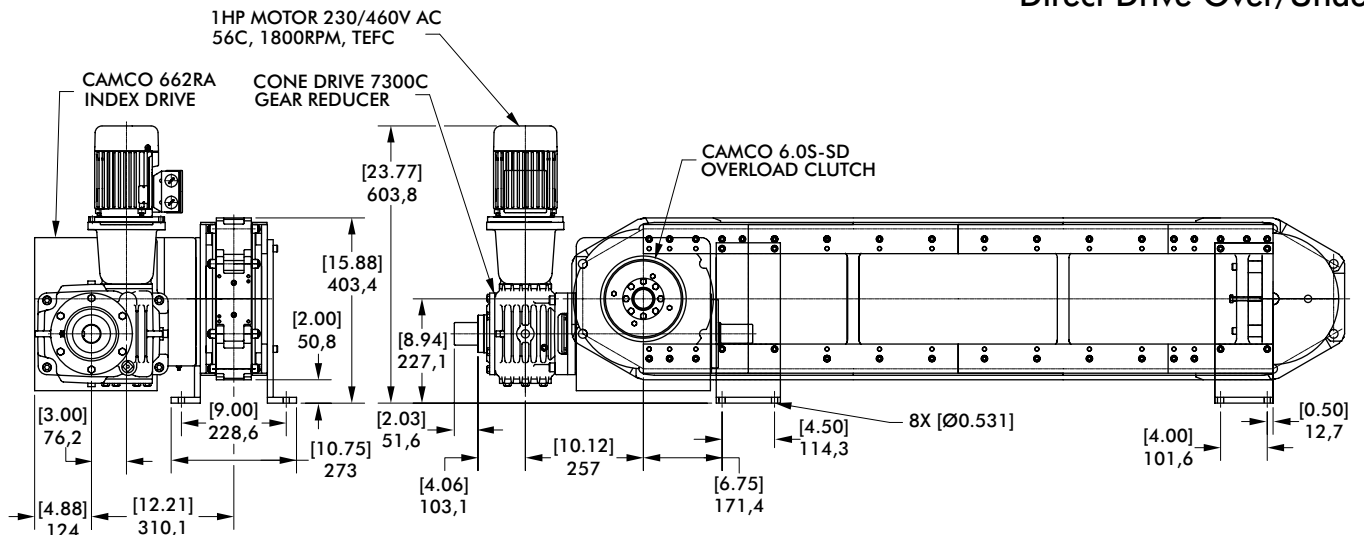
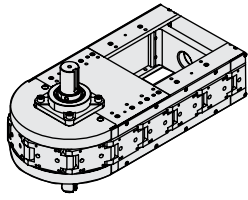
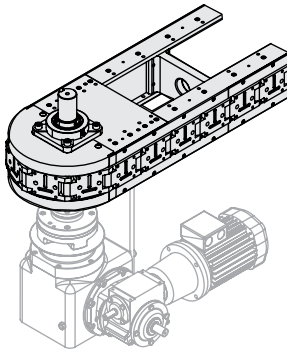

TABLE-TOP MODULAR CONVEYORS

Conveyor Types



MODULE ONLY



CAROUSEL-SHAFT DRIVEN

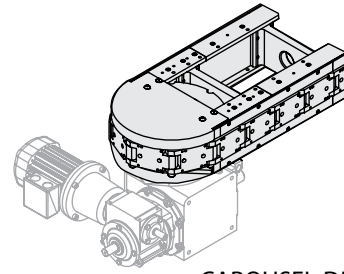

CAROUSEL-DIRECT DRIVEN

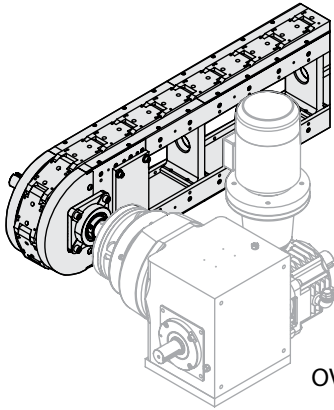

OVER-UNDER SHAFT DRIVEN

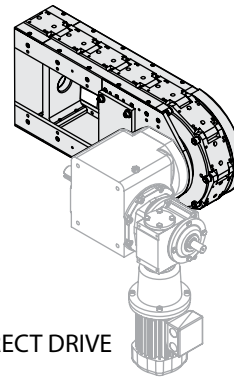

OVER-UNDER DIRECT DRIVE

Carousel Indexer Position

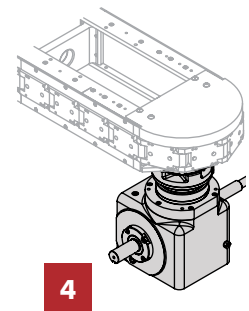
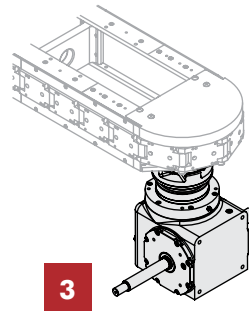
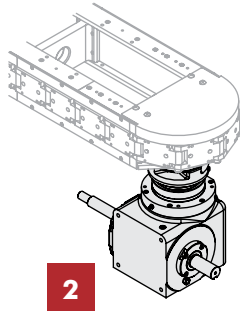
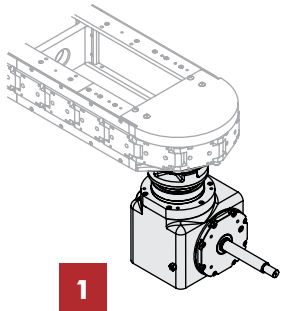

Over/Under Side

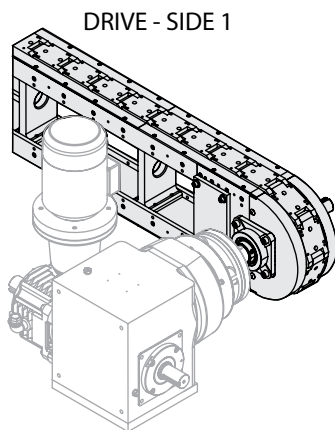

DRIVE - SIDE 1

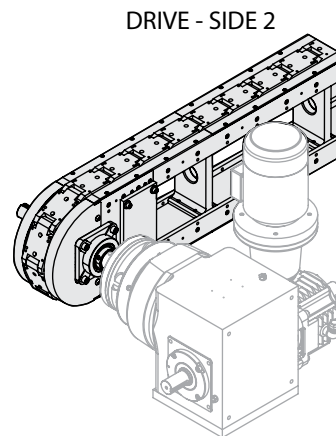

DRIVE - SIDE 2

TABLE-TOP MODULAR CONVEYORS

Options

Tooling Plate Options Carousel

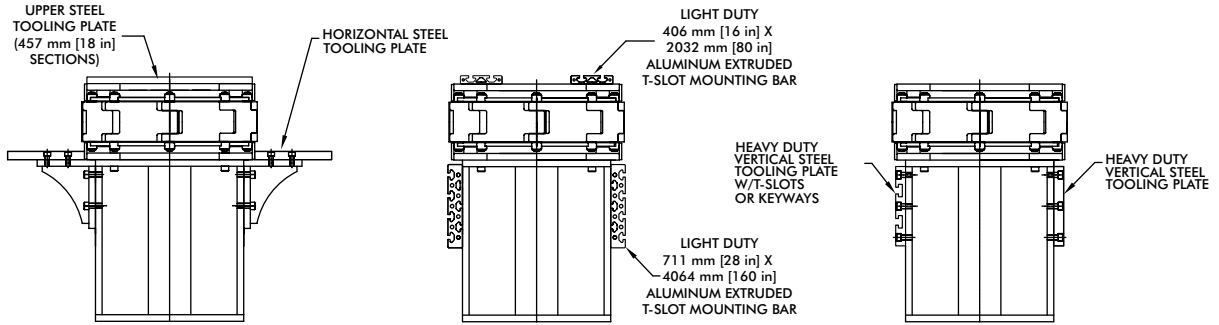

Tooling Plate Options Over/Under

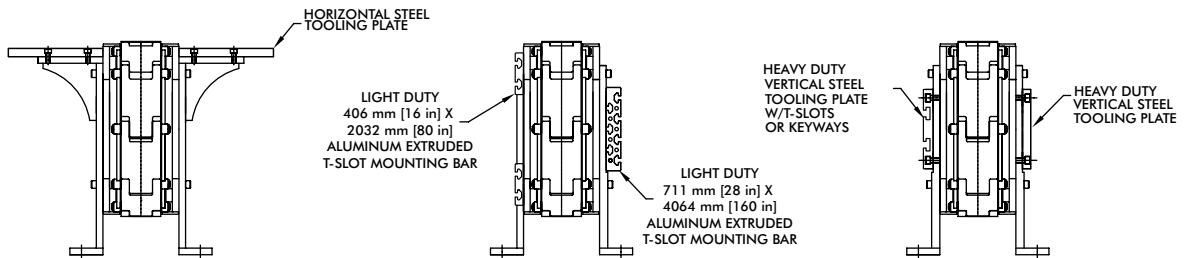

Support Leg Options

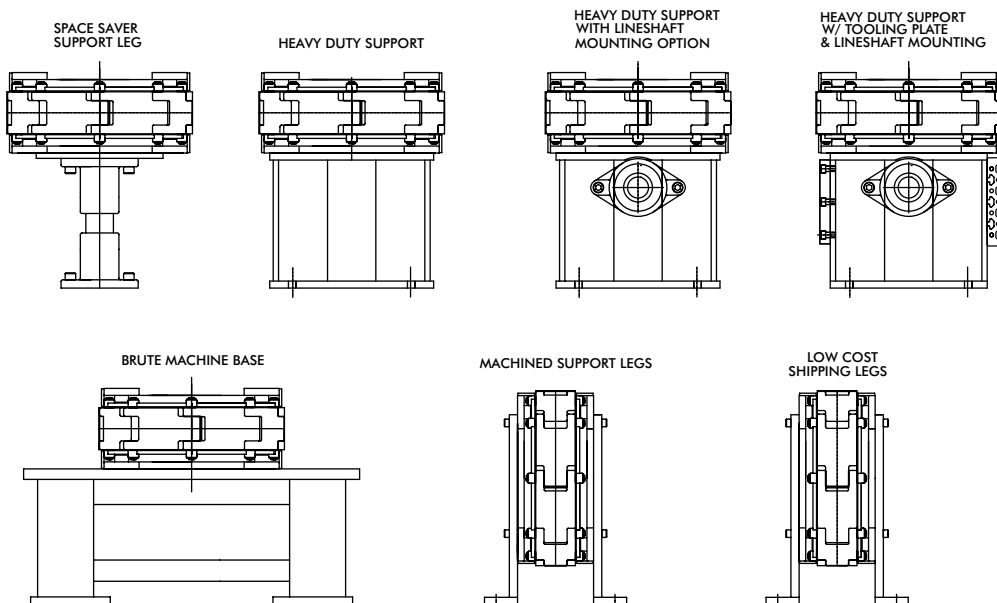
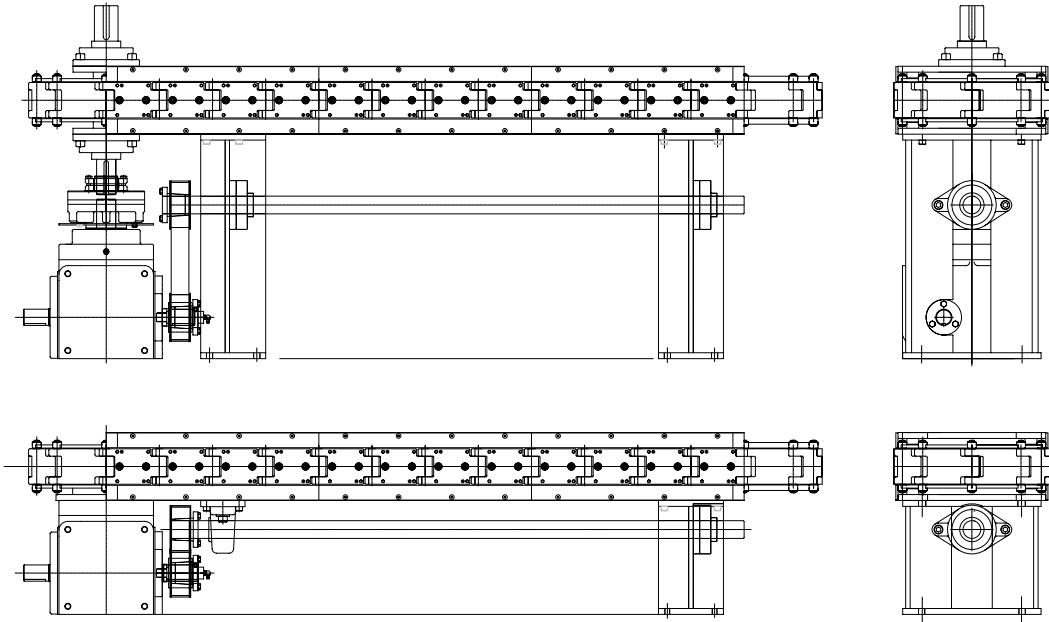

TABLE-TOP MODULAR CONVEYORS

Options

Lower Lineshaft Options Belt Driven



Lower Lineshaft Options Direct Driven

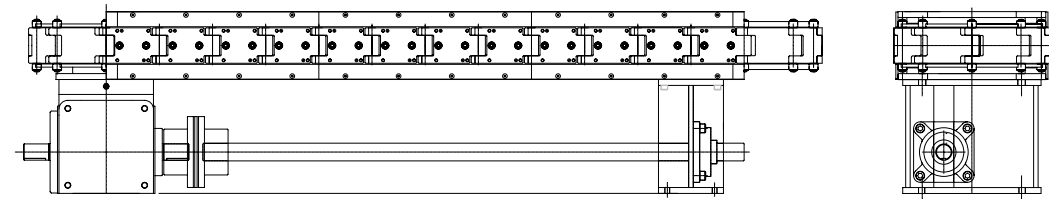

Drive Side Lineshaft Options Belt Driven

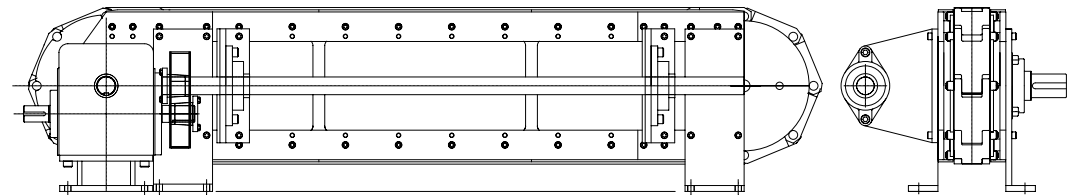

Drive Side Lineshaft Options Direct Driven

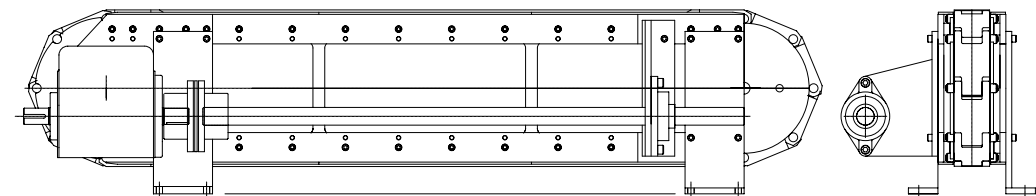
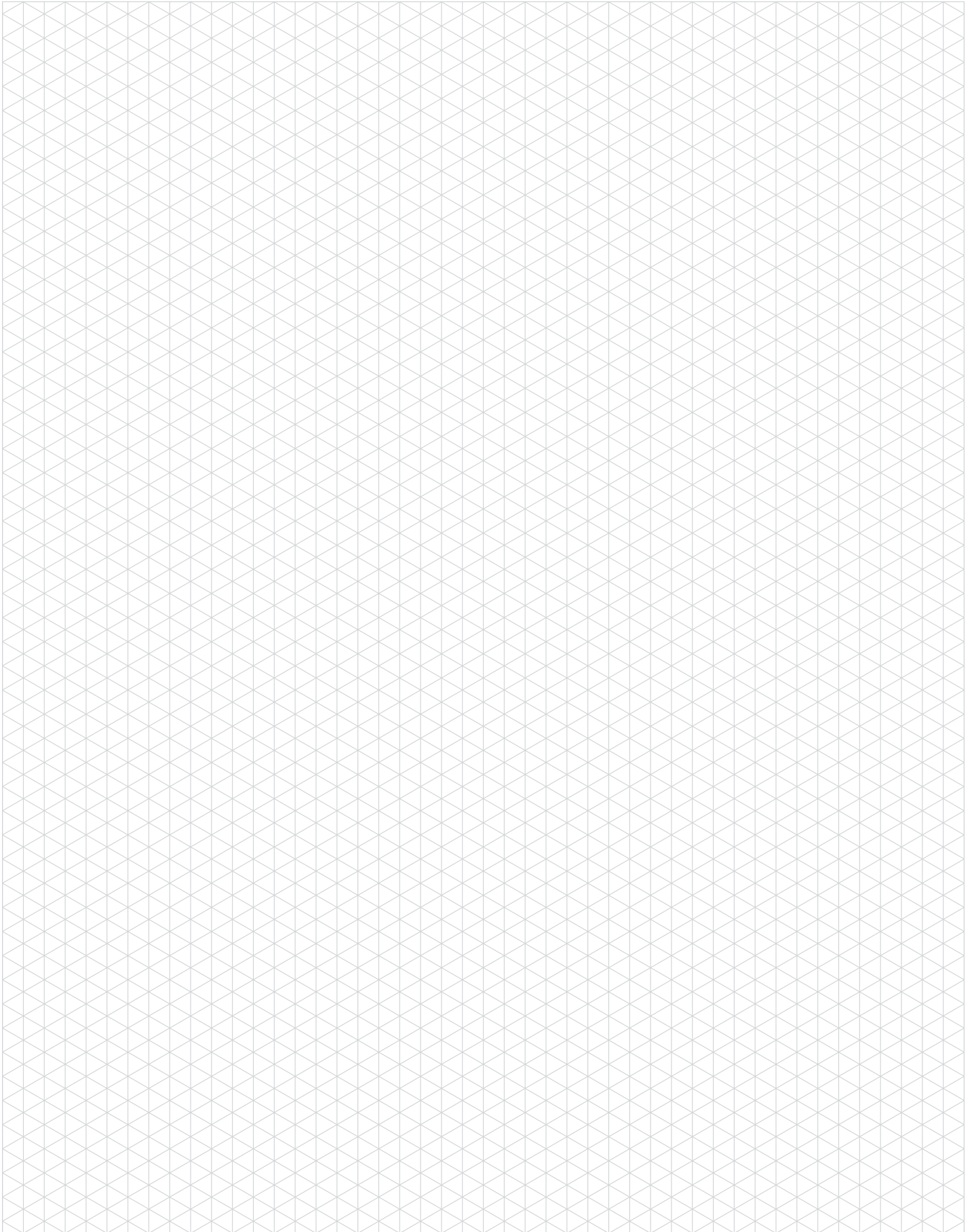

TABLE-TOP MODULAR CONVEYORS



PRECISION INDEXING SOLUTIONS

Table of Contents

INDEXERS

Servo Positioners



GTB Series
Globoidal (Roller Gear)
Servo Positioner.....IN-SRV-1



RSD Series
Rotary Servo Drives.....IN-SRV-39

Mechanical Indexers



RDM Series
Rotary Index Drive IN-MCH-2



RD Series
Roller Dial Index Drive..... IN-MCH-18



E Series
Heavy-Duty Index Drive IN-MCH-30



RA Series
Right Angle Index Drive IN-MCH-42



RGD/RGS Series
Roller Gear Index Drive IN-MCH-52



P Series
Parallel Shaft/Flange Drive.... IN-MCH-72



RNG Series
Ring Drive Dial Indexer.....IN-MCH-84

OVERLOAD CLUTCHES



Overload Clutches
Output Overload..... IN-CLU-1

CUSTOM CAMS



Custom Cams
Cam Design Solutions IN-CAM-1

CONVEYORS



Rite-Link Series
Thin-Profile.....IN-CNV-1



Precision Link Series
Table-TopIN-CNV-4



Precision Link Series
Heavy-Duty IN-CNV-16

PARTS HANDLERS



LPP Series
Linear Part Handlers IN-PRT-2



RPP Series
Rotary Part Handlers IN-PRT-8

HEAVY DUTY MODULAR CONVEYORS

Features | Table of Contents

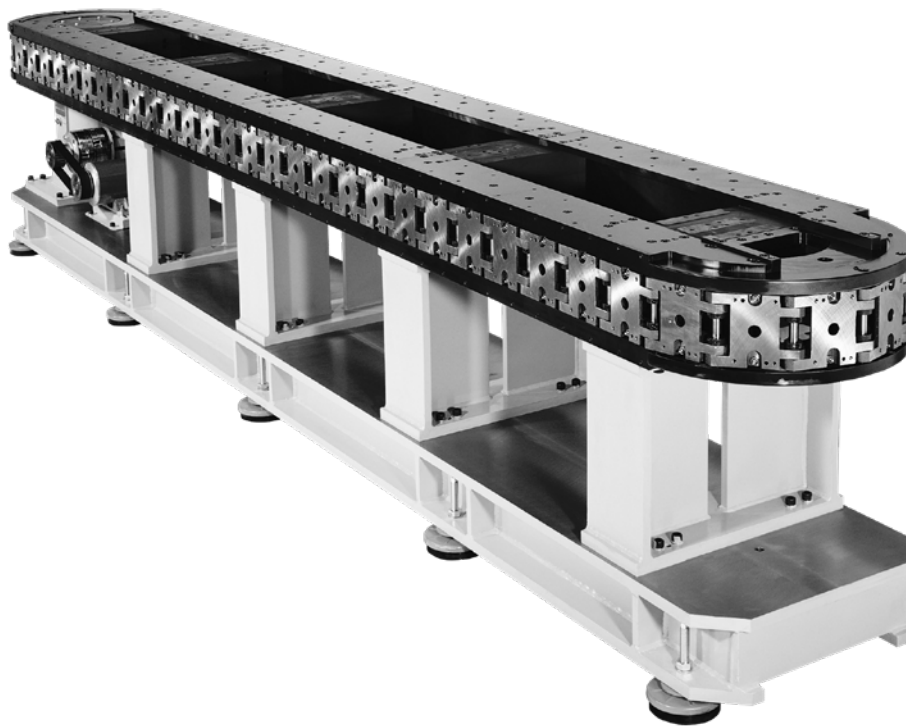

Features:

CAMCO Heavy Duty Precision Link Conveyors combine excellent accuracy with high load capacity to provide the versatility needed to meet virtually any automated assembly or manufacturing challenge.

Standard link lengths of 6.0", 9.0" and 12"

Over/Under and Carousel configurations

Precision links with roller bearing cam followers for smooth transfer and long life

Provided with heavy-duty legs and a precision machined base designed to hold large loads and maintain system accuracy

Available with adjustable soft machine mounts to accommodate inconsistent on-site flooring

Customize length and height and add optional line shafts or tooling plates to fit your application

Table of Contents

How to Order	3
Conveyor Options	4
6.0 Inch Heavy Duty	5
9.0 Inch Heavy Duty	7
12.0 Inch Heavy Duty	9

HEAVY DUTY MODULAR CONVEYORS

How To Order

Required Information

- **Link Size:** 1.5, 2.0, 3.0, 4.5, 6.0, 9.0 or 12.0 inch
- **Type:** Table Top or Heavy Duty
- **Style:** Over/Under or Carousel
- **Length:** Standard per catalog or Custom, expressed as center distance, in inches
- **Height:** Standard per catalog or Custom, in inches

Required Information when ordering Drive Package

- **Type:** Standard, Alternate, Heavy-Duty or Special
- **Drive Side:** 1 or 2 (for Over/Under)
- **Index Distance:** In inches
- **Indexer Model:** Specific model number or special

Technical Assistance

All Precision Link Conveyor applications are verified by a CAMCO sales agent using the CAMCO Sizing Program.

Your CAMCO agent is available to make all sizing calculations for you.

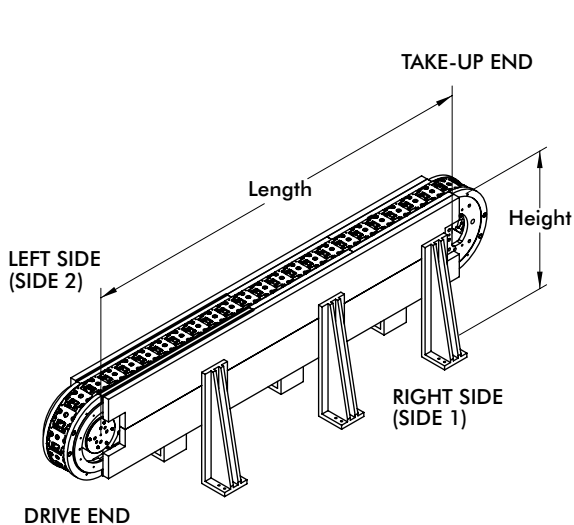

OVER/UNDER

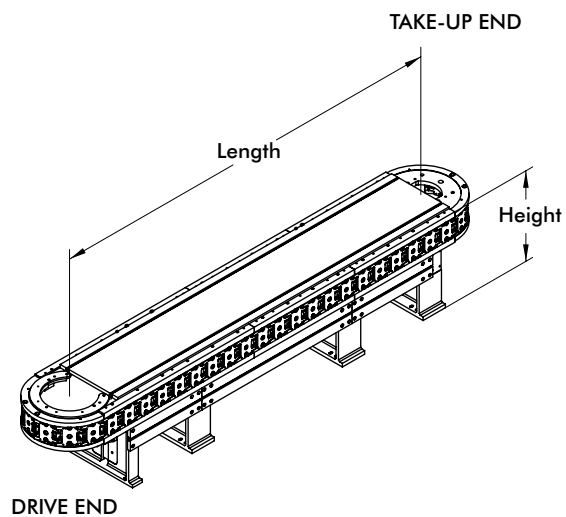

CAROUSEL

HEAVY DUTY MODULAR CONVEYORS

Options

CAMCO offers a wide variety of standard and custom options on all precision link conveyors. Tooling plates and conveyor mainframes can be ordered with custom hole configurations or burnouts. Other standard options include timing chains, timing belts and extended lineshafts. Standard drive package options include CAMCO indexers with AC motors and clutch-brakes, DC motors or servo motors. CAMCO's special Indexer output overload clutches are highly recommended to protect the indexer, link assembly and tooling.

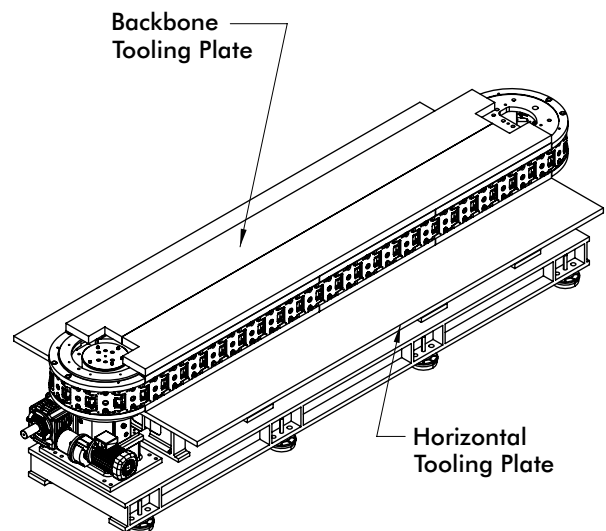
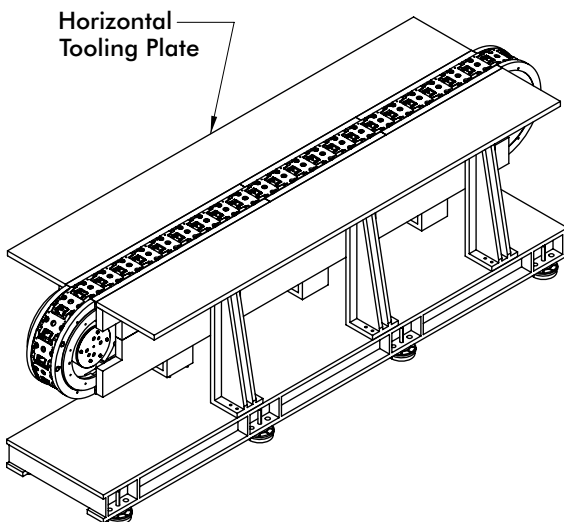
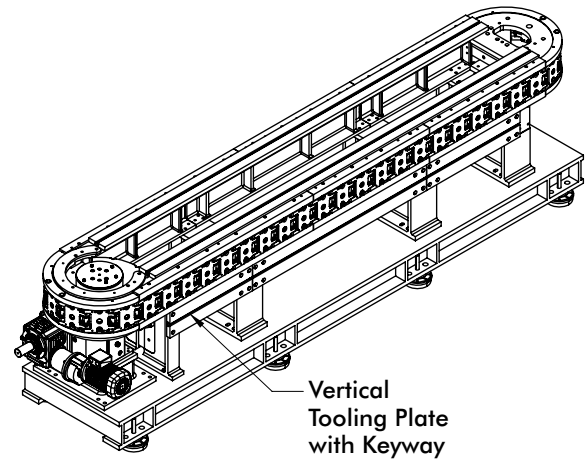
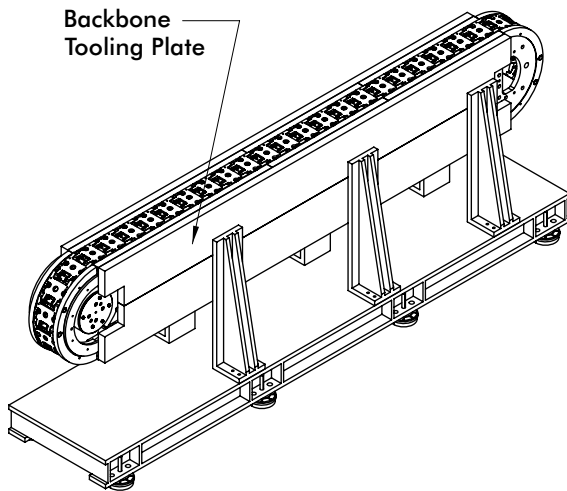

Using Cambot Parts Handlers with Precision Link Conveyors

Cambot linear pick-and-place parts handlers have custom cam motions incorporated into each unit, providing complex synchronize timings for your application. They can be mounted onto the backbone tooling plates of the conveyor. Cambot linear pick-and-place parts handlers can be belt driven off a common line shaft for perfect synchronization. See the Rotary Parts Handler section (page IN-RPP-2) for other possible configurations, such as a rotary pick-and-place device loading parts from a continuous line conveyor to a CAMCO index drive conveyor.

6.0 INCH HEAVY DUTY SERIES

Heavy Duty Modular Conveyors | Dimension

Link

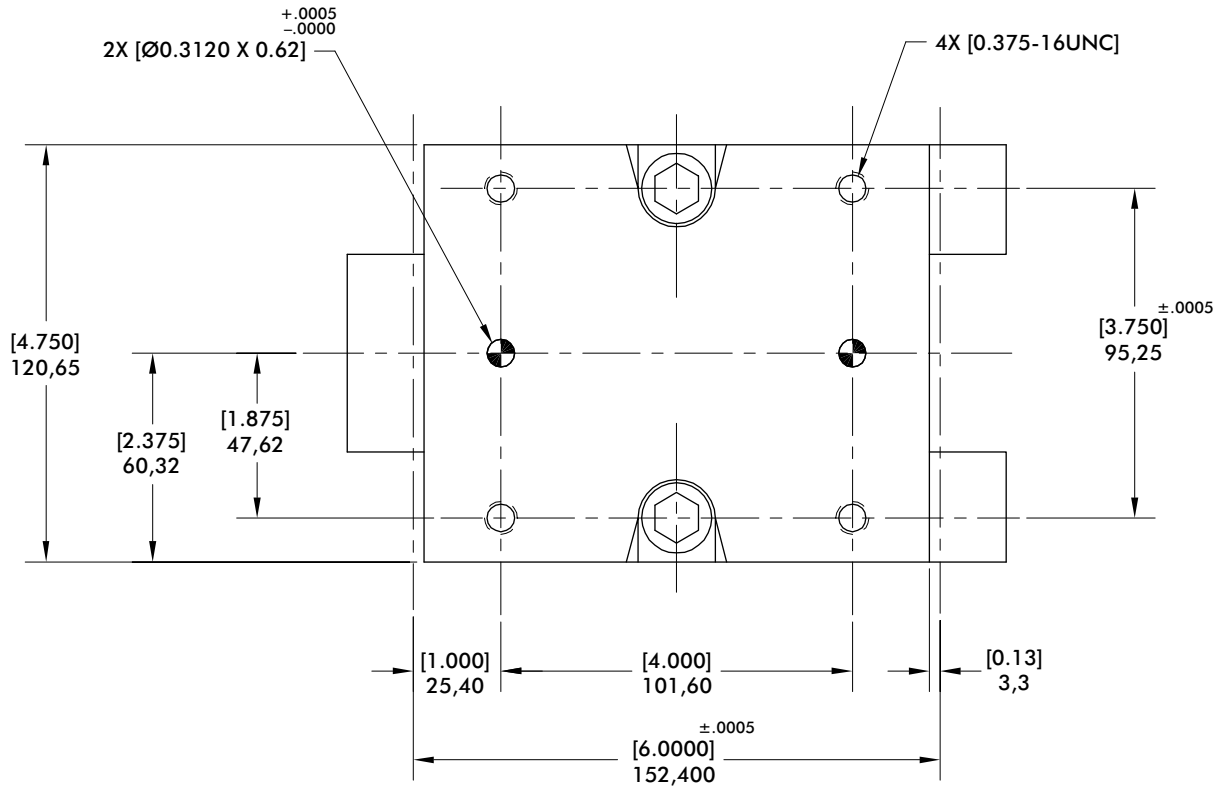

Modular Conveyor (drive package)

Standard Drive Package

- 1301RD Intermittor
- 73500C Reducer
- 5 HP AC Motor
- MDB-1125 Air Clutch-Brake
- Cycle Cam & Limit Switch

Index Distance mm [in]	Indexer Stops
152,4 [6.00]	12
304,8 [12.00]	6
457,2 [18.00]	4
609,6 [24.00]	3

6.0 INCH HEAVY DUTY SERIES

Heavy Duty Modular Conveyors | Configurations

Carousel

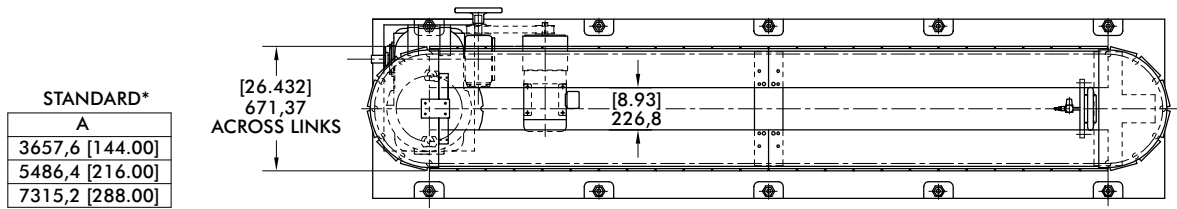

STANDARD*

A
3657,6 [144.00]
5486,4 [216.00]
7315,2 [288.00]

*Conveyor lengths can be customized for your application. Please consult factory.

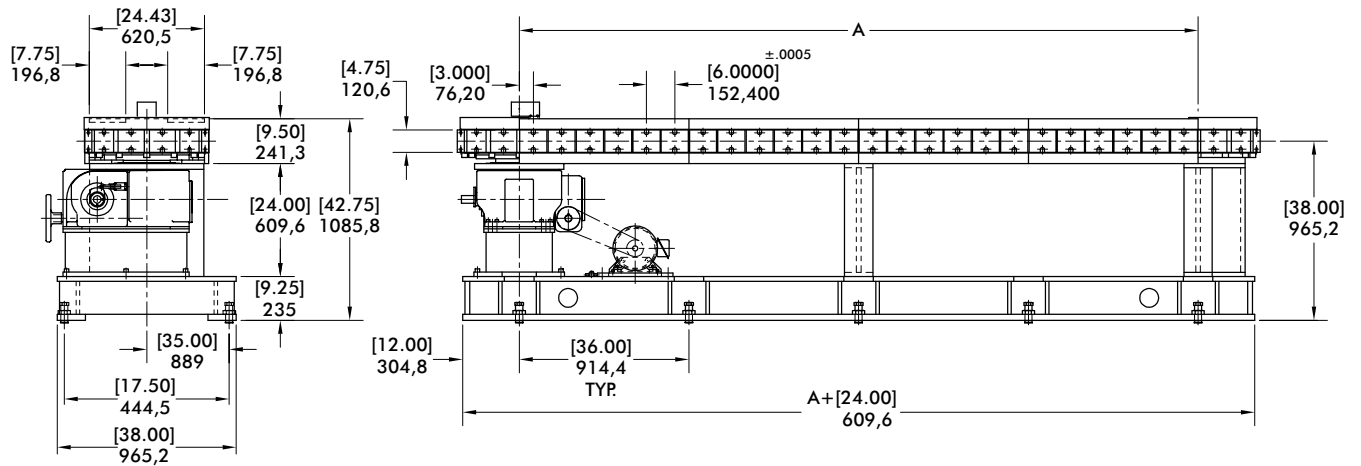

Over/Under

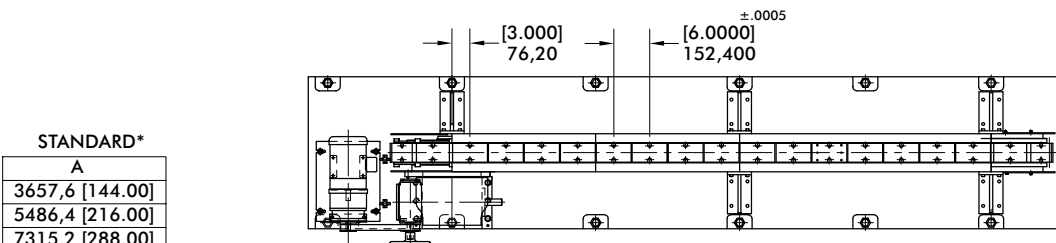

STANDARD*

A
3657,6 [144.00]
5486,4 [216.00]
7315,2 [288.00]

*Conveyor lengths can be customized for your application. Please consult factory.

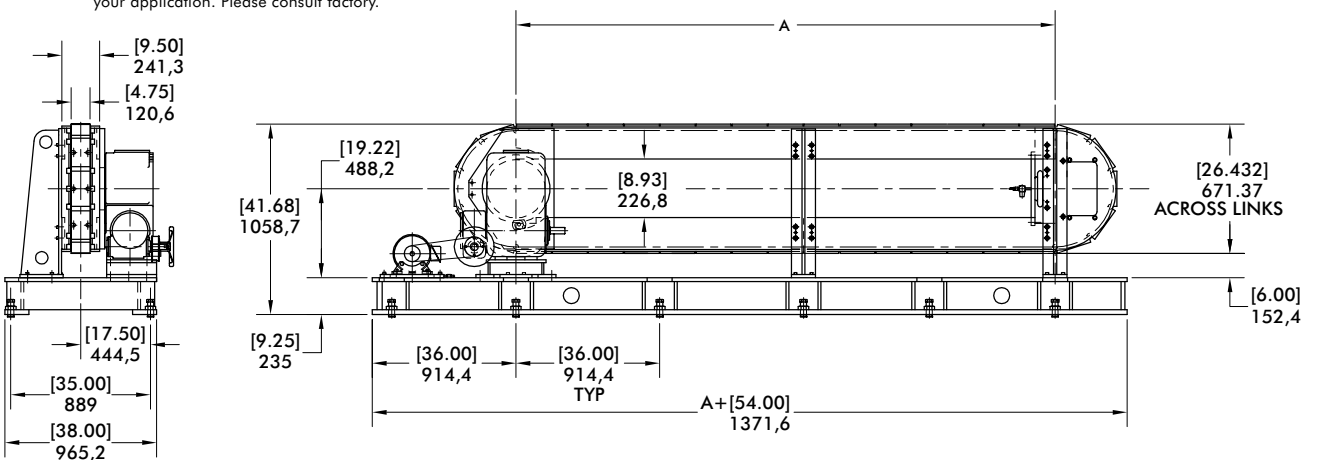

9.0 INCH HEAVY DUTY SERIES

Heavy Duty Modular Conveyors | Dimensions

Link

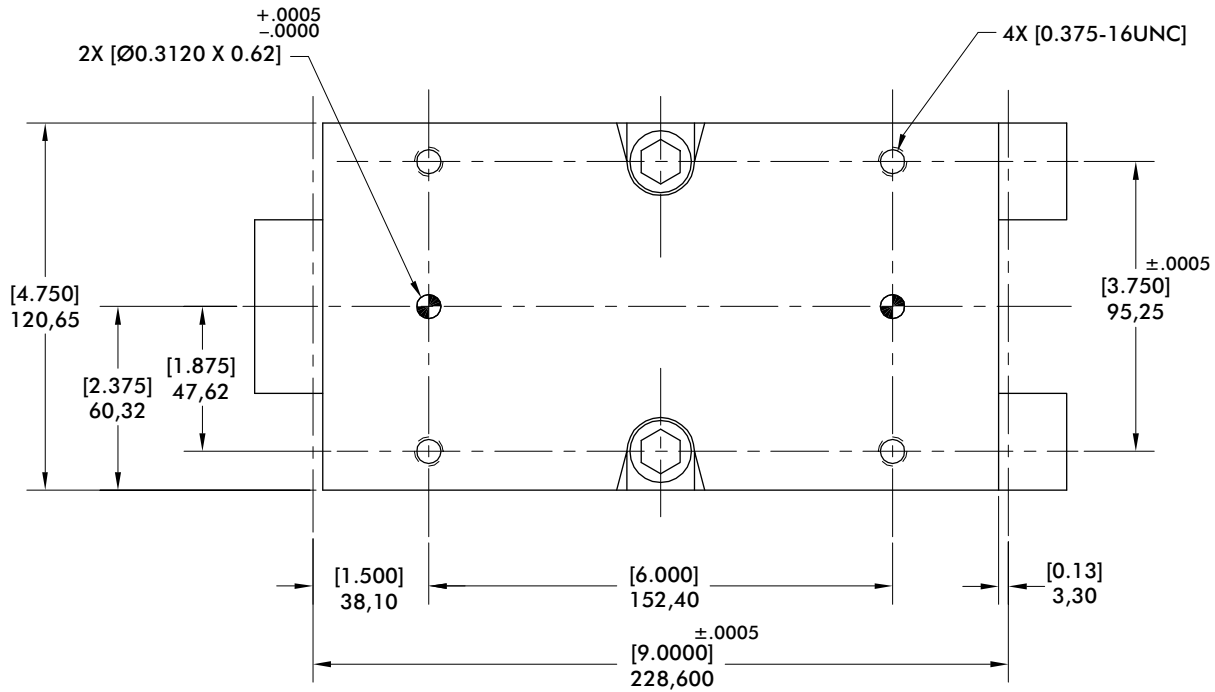

Modular Conveyor (drive package)

Standard Drive Package

- 1301RD Intermittor
- 73500C Reducer
- 5 HP AC Motor
- MDB-1125 Air Clutch-Brake
- Cycle Cam & Limit Switch

Index Distance mm [in]	Indexer Stops
228,6 [9.00]	12
457,2 [18.00]	6
914,4 [27.00]	4
609,6 [36.00]	3

9.0 INCH HEAVY DUTY SERIES

Heavy Duty Modular Conveyors | Configurations

Carousel

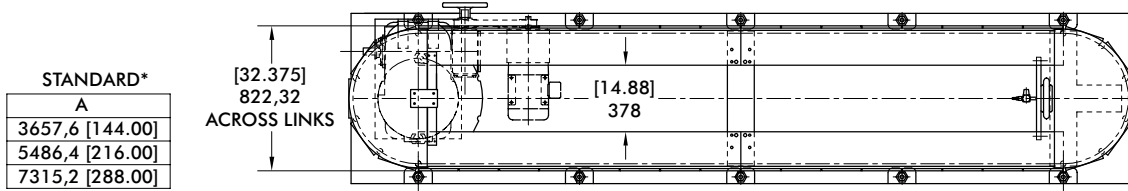

*Conveyor lengths can be customized for your application. Please consult factory.

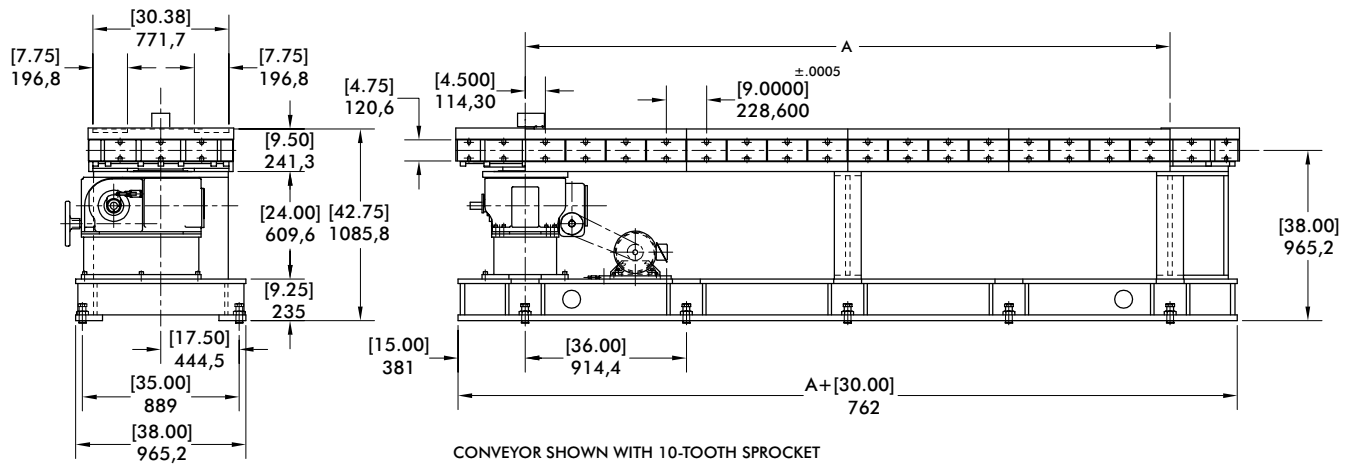

Over/Under

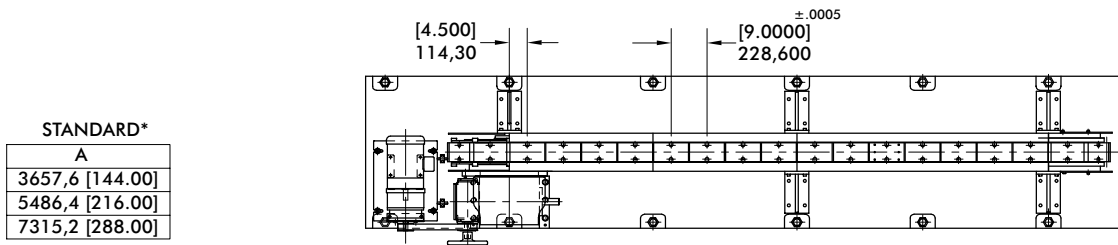

*Conveyor lengths can be customized for your application. Please consult factory.

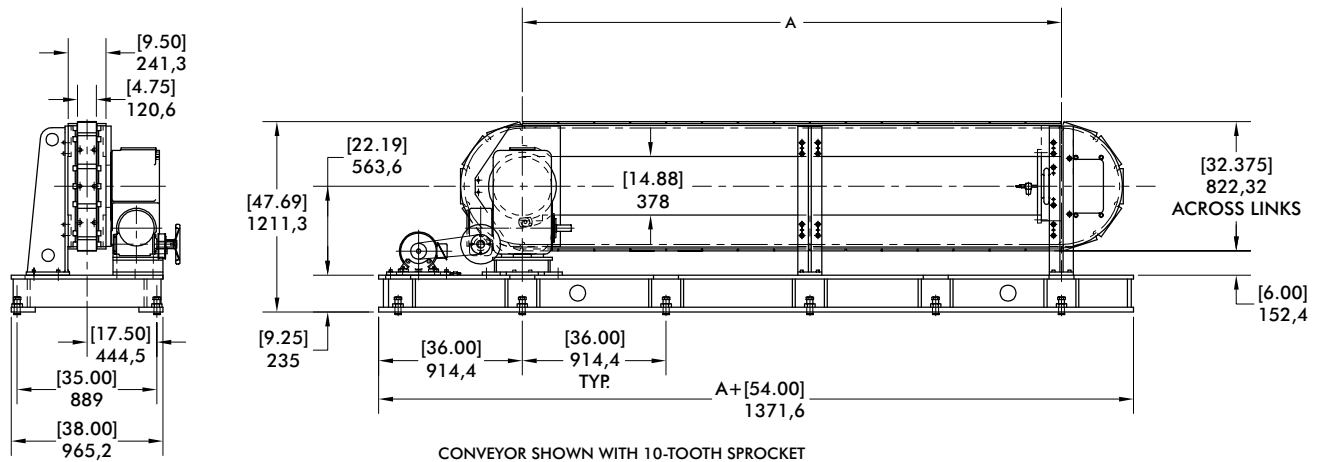

12.0 INCH HEAVY DUTY SERIES

Heavy Duty Modular Conveyors | Dimensions

Link

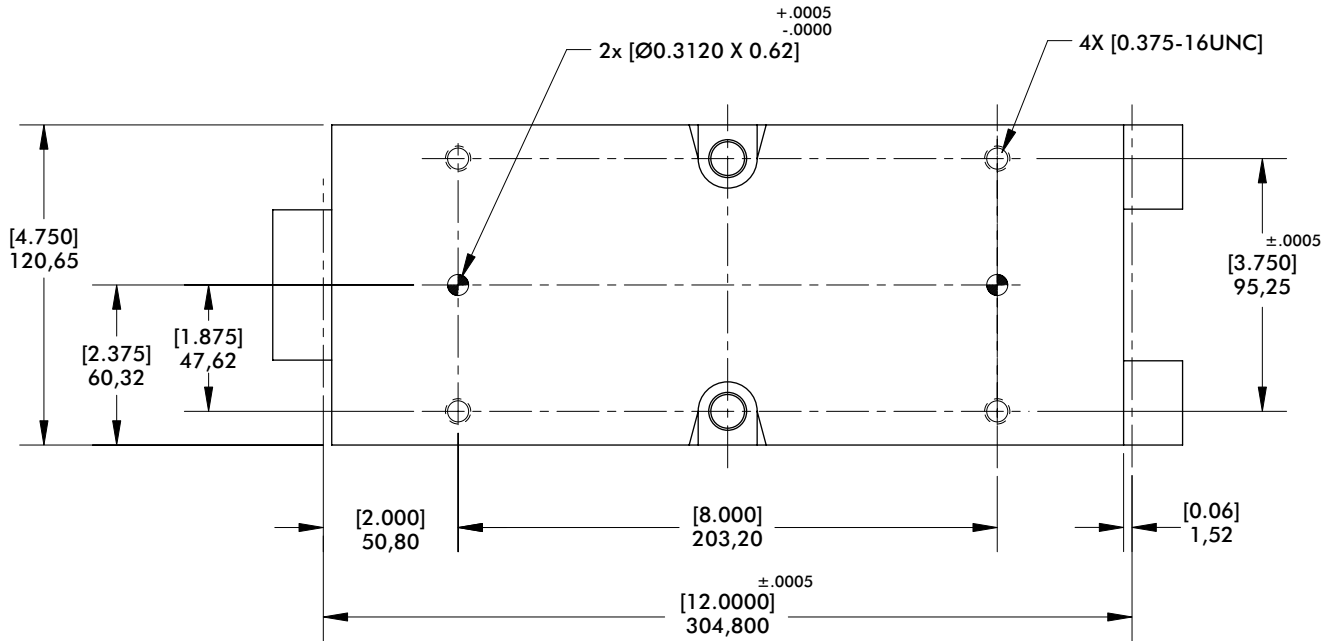

Modular Conveyor (drive package)

Standard Drive Package

- 1301RD Intermittor
- 7500C Reducer
- 5 HP AC Motor
- MDB-1125 Air Clutch-Brake
- Cycle Cam & Limit Switch

Index Distance mm [in]	Indexer Stops	Sprocket
304,8 [12]	8, 10, 12	8T, 10T, 12T
609,6 [24]	4, 5, 6	8T, 10T, 12T
914,4 [36]	4	12T
1219,2 [48]	2, 3	8T, 12T

12.0 INCH HEAVY DUTY SERIES

Heavy Duty Modular Conveyors | Configurations

Carousel

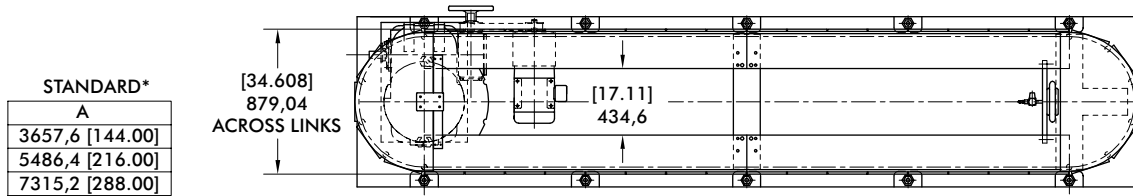

STANDARD*	
A	
3657,6	[144.00]
5486,4	[216.00]
7315,2	[288.00]

*Conveyor lengths can be customized for your application. Please consult factory.

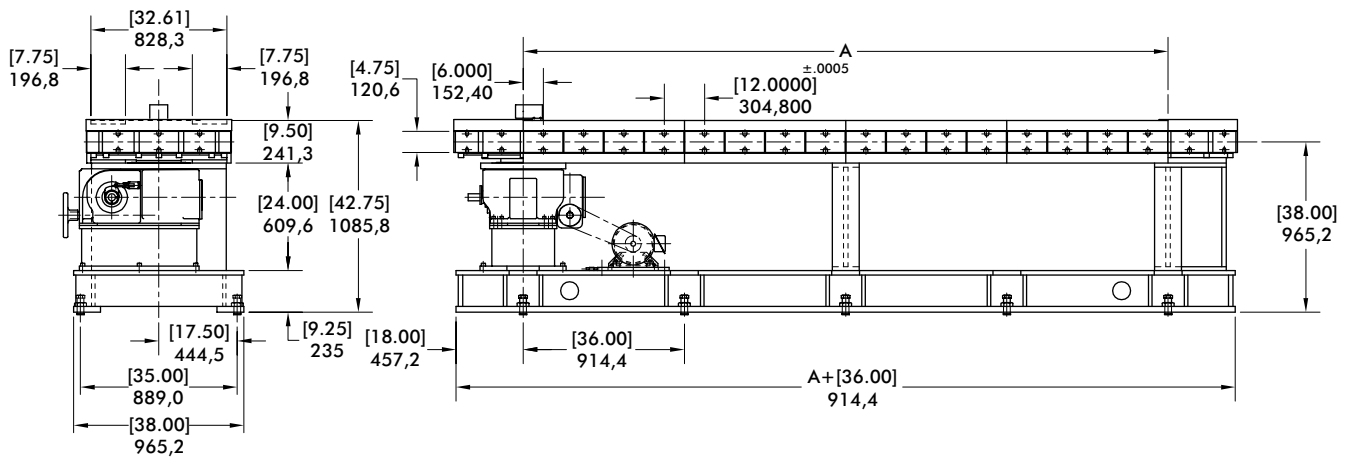

Over/Under

STANDARD*	
A	
3657,6	[144.00]
5486,4	[216.00]
7315,2	[288.00]

*Conveyor lengths can be customized for your application. Please consult factory.

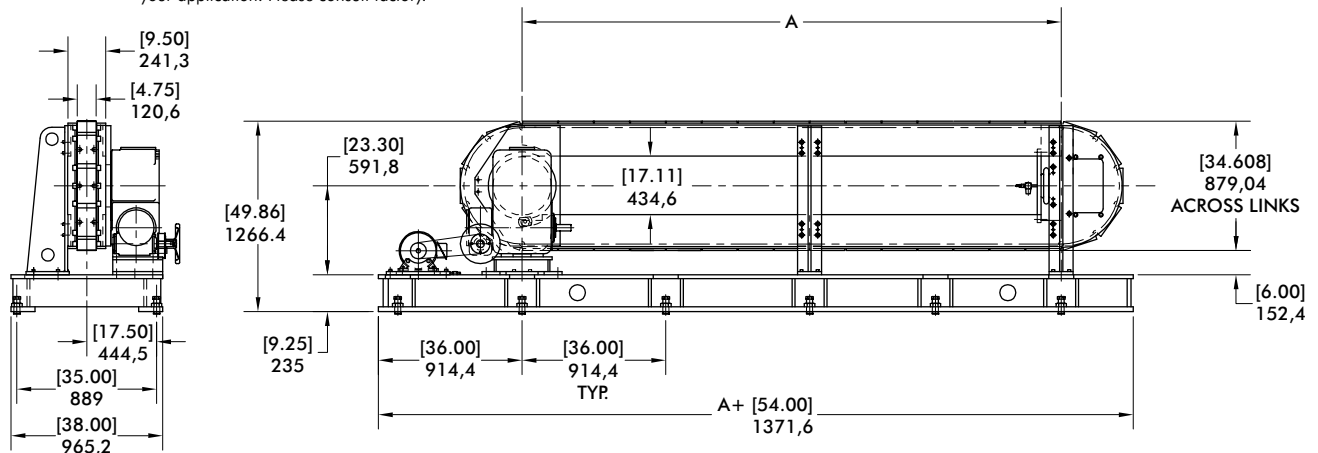

LINEAR PART HANDLER

Gripper Mounting Accessory

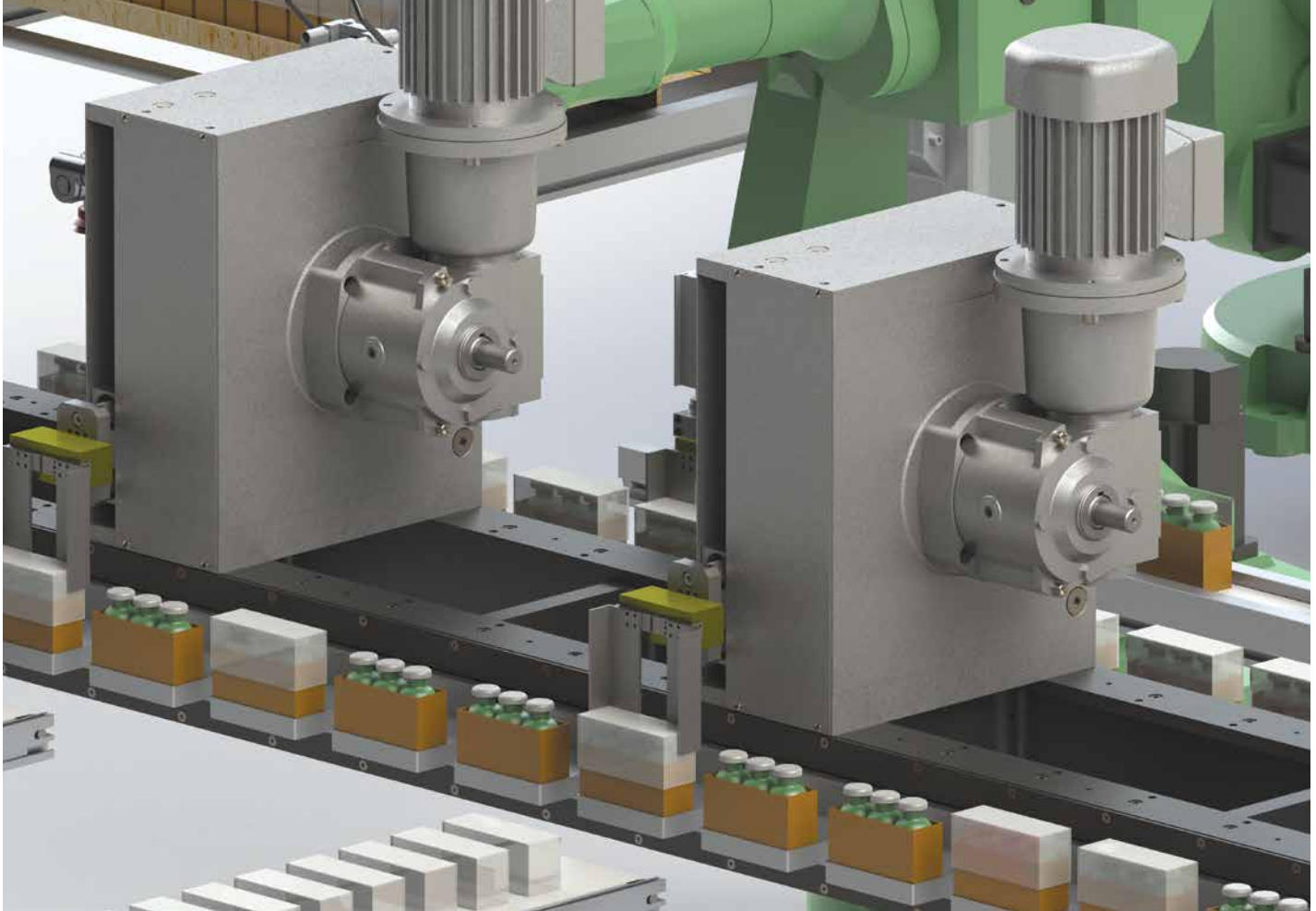

Indexer driving a conveyor and Linear Part Handlers

- Operation can be asynchronous (cycle on demand) – a single index followed by a variable dwell time, or the operation can be continuous.
- Index motion time is changed by changing the motion profile of the servo motor.
- Dwell time is variable. Single axis servo or multiple axis servo controllers can be used.
- More than 60 cycles per minute – maximum cycle rate can be determined by your application engineer.

LINEAR PART HANDLER

Features | Table of Contents



Features:

CAMCO Cambot® Linear Parts Handlers, combined with other DESTACO products, offer a low maintenance, cost-effective solution for a complete parts handling package.

Cost effective design for low-cost operation

- Reliable CAMCO mechanical cam design
- Lubed for Life

Easy integration with other DESTACO products for one-stop shopping

- Camco Modular Precision Link Conveyors and Ring Drives
- DESTACO Vacuum products
- Robohand Direct Connect™ Grippers (no adapter plates) and E-Gripper

Customized for your application

- Input shaft available on either side for ease of integration
- Line shaft drive or gear reducer and motor drive package for synchronous or asynchronous operation

Standard or custom strokes and timing designed for your specific requirements

Applications:

Automated production systems with small parts transfer such as consumer products, electronics, and medical device assembly and test.

Table of Contents

How to Order	3
M100/M150	5
Gripper Mounting Block	6

LINEAR PART HANDLER

How To Order

LPP Ordering Procedure

1. Model
2. Lift (Vertical) Stroke
3. Transfer (Horizontal) Stroke

Standard Strokes: Lift x Transfer mm [in]	
M100	M150
15.0 [0.59] x 100 [3.94]	15 [0.59] x 150 [5.91]
45 [1.77] x 100 [3.94]	45 [1.77] x 150 [5.91]
65 [2.56] x 20 [0.79]	75 [2.95] x 50 [1.97]
65 [2.56] x 60 [2.36]	75 [2.95] x 110 [4.33]
65 [2.56] x 100 [3.94]	75 [2.95] x 150 [5.91]

4. Output Sequence (Standard or Custom)

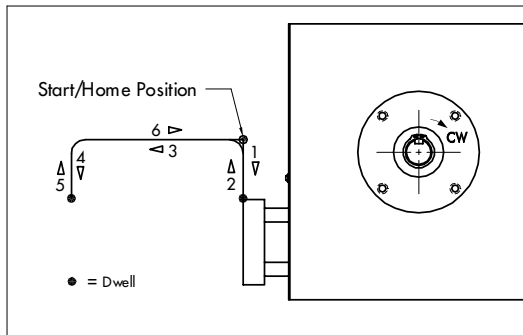

5. Drive Page including Gear Reducer, Motor, and AC Drive

Model	Gear Reducer	AC Motor	1 hp AC Drive Input Voltage (select 1)		
M100	R180	1/3 hp	120 VAC	240 VAC	480 VAC
M150	R225	3/4 hp	120 VAC	240 VAC	480 VAC

LINEAR PART HANDLER

Mounting Position

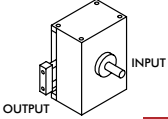
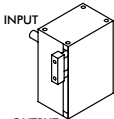
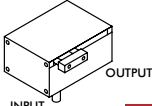
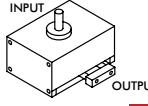
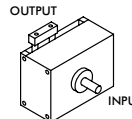
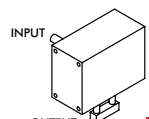
OHUI (output horizontal, under input)	OHOI (output horizontal, over input)	OHID (output horizontal, input down)	OHIU (output horizontal, input up)	VU (output vertical up)	VD (output vertical down)
 1	 2	 3	 4	 5	 6

Gear Reducer Mounting Positions

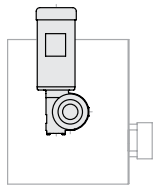
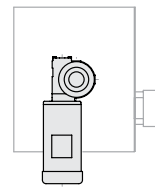
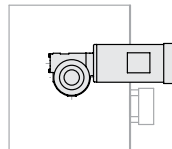
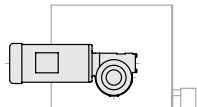
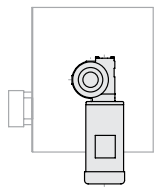
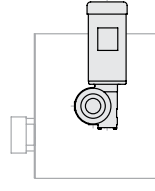
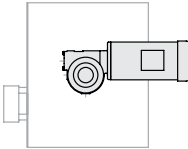
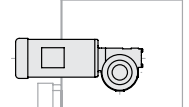
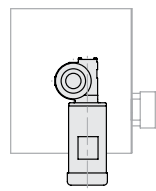
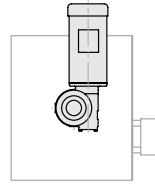
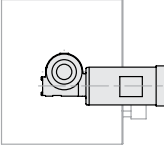
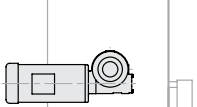
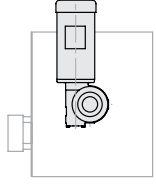
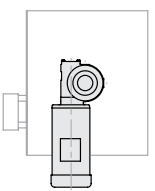
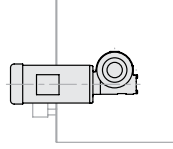
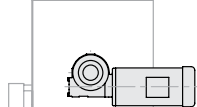
		Mounting "A"		Mounting "B"	
		RH	LH	RH	LH
SIDE 1	 A	 B	 C	 D	
	SIDE 2	 E	 F	 G	 H
		Mounting "C"		Mounting "D"	
		RH	LH	RH	LH
SIDE 1	 J	 K	 L	 M	
	SIDE 2	 N	 P	 R	 S

M100/M150 SERIES

Linear Part Handler | Dimensions and Technical Information

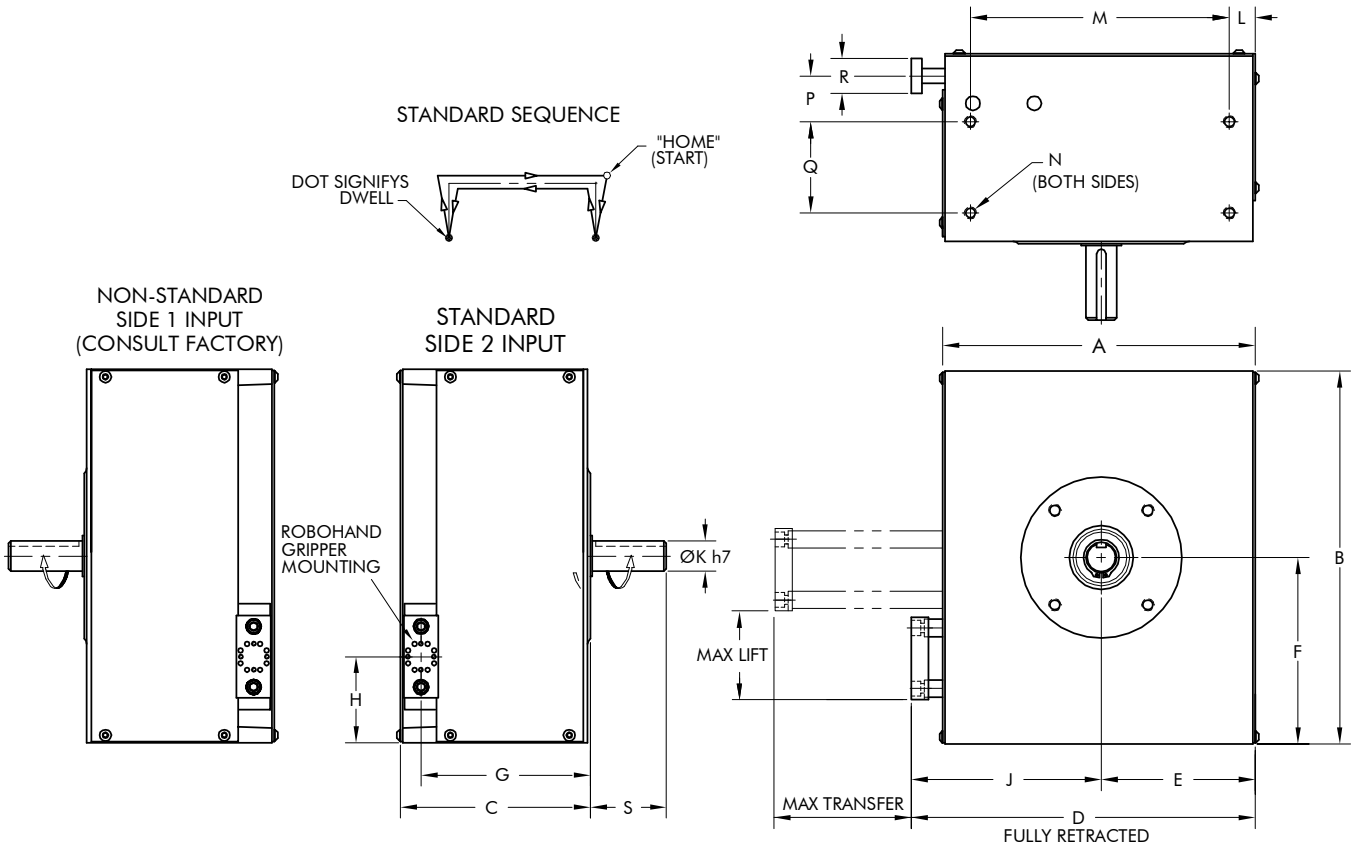

Model	A	B	C	D	E	F	G	H	J	K	L	M	N	P	Q	R	S
M100	[9.88] 251.0	[11.42] 290.0	[5.71] 145.0	[11.01] 279.7	[4.84] 123.0	[5.71] 145.0	[5.12] 130.0	[2.56] 65.0	[6.18] 157.0	[0.98] 25.0	[0.47] 12.0	[8.86] 225.0	4 x M8	[1.57] 40.0	[2.56] 65.0	[1.00] 25.4	[1.97] 50.0
M150	[13.07] 332.0	[15.75] 400.0	[6.69] 170.0	[14.41] 366.0	[6.30] 160.0	[7.87] 200.0	[5.83] 148.0	[3.54] 90.0	[8.11] 206.0	[1.18] 30.0	[0.59] 15.0	[11.81] 300.0	4 x M10	[1.57] 40.0	[3.15] 80.0	[2.01] 51.0	[2.17] 55.0

Technical Specifications

Model	Maximum Lift mm [in]	Maximum Transfer mm [in]	Capacity at 30 rpm kg [lb]	Capacity at 60 rpm kg [lb]
M100	65.0 [2.56]	100.0 [3.94]	8 [18]	3.6 [8]
M150	75.0 [2.95]	150.0 [5.91]	18 [40]	9 [20]

Model	Lift		Transfer	
	Accuracy	Repeatability	Accuracy	Repeatability
M100	±.13 mm [±.005 in]	±.03 mm [±.001 in]	±.08 mm [±.003 in]	±.03 mm [±.001 in]
M150	±.20 mm [±.008 in]	±.08 mm [±.003 in]	±.08 mm [±.003 in]	±.03 mm [±.001 in]

M100/M150 SERIES

Linear Part Handler | Accessories

Gripper Mounting Block

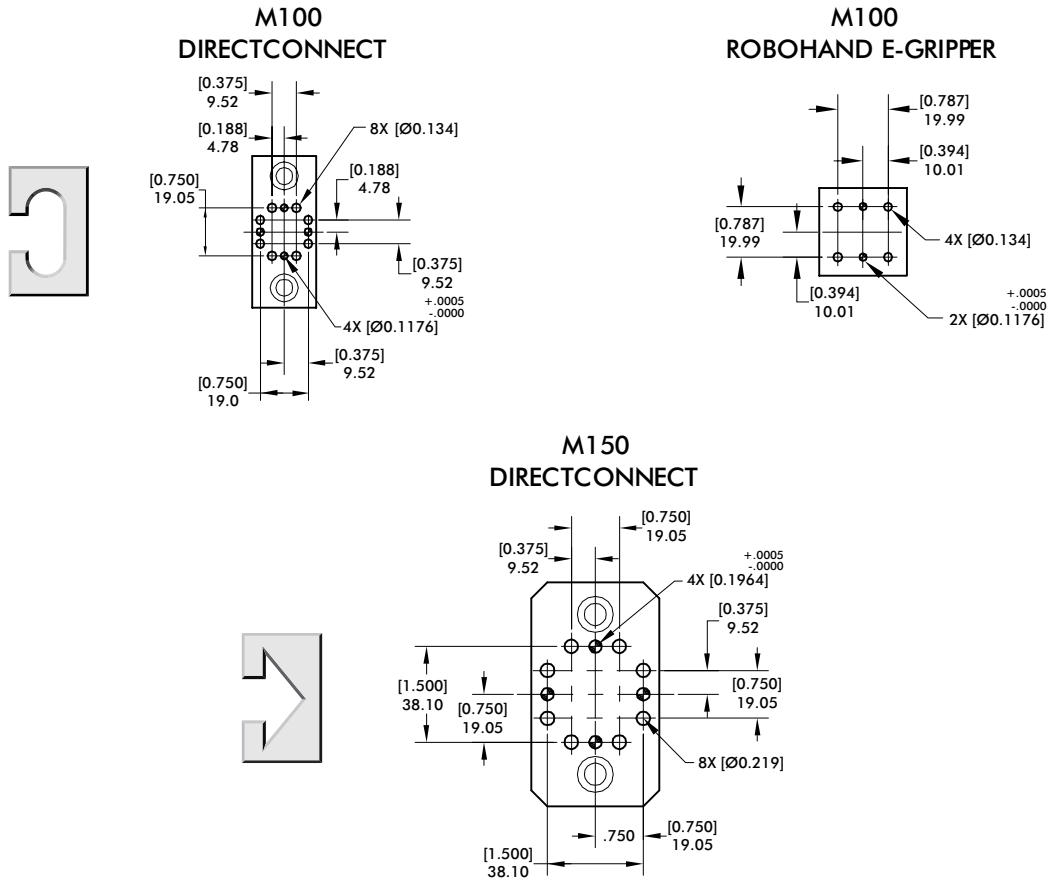

RoboHand DirectConnect Grippers & Rotaries

Consult the DESTACO Automation Catalog or your local sales representative for information about these items.

Model	E-Gripper	DPDS/DPDL	DPG	DPP	DPW	DCT	DRF
M100	RPE-100M RPE-101M	DPDS-047M DPDS-056M DPDL-047M DPDL-056M	N/A	DPP-10M-06 DPP-10M-12 DPP-14M-15 DPP-14M-25	DPW-250M-1 DPW-250M-2	DCT-12M DCT-16M DCT-20M	N/A
M150	N/A	DPDS-088M DPDS-125M DPDL-088M DPDL-125M	DPG-10M-1 DPG-10M-2 DPG-10M-3 DPG-10M-4	DPP-20M-25 DPP-20M-28 DPP-28M-31 DPP-28M-50	DPW-375M-1 DPW-375M-2 DPW-500M-1 DPW-500M-2	DCT-25M	DRF/DRG-075M DRF/DRG-094M DRF/DRG-106M

ROTARY PART HANDLER

Product Overview

INDEXERS

Servo Positioners



GTB Series
Globoidal (Roller Gear)
Servo Positioner.....IN-SRV-1



RSD Series
Rotary Servo Drives.....IN-SRV-39

Mechanical Indexers



RDM Series
Rotary Index Drive IN-MCH-2



RD Series
Roller Dial Index Drive..... IN-MCH-18



E Series
Heavy-Duty Index Drive IN-MCH-30



RA Series
Right Angle Index Drive IN-MCH-42



RGD/RGS Series
Roller Gear Index Drive IN-MCH-52



P Series
Parallel Shaft/Flange Drive.... IN-MCH-72



RNG Series
Ring Drive Dial Indexer.....IN-MCH-84

OVERLOAD CLUTCHES



Overload Clutches
Output Overload..... IN-CLU-1

CUSTOM CAMS



Custom Cams
Cam Design Solutions IN-CAM-1

CONVEYORS



Rite-Link Series
Thin-Profile.....IN-CNV-1



Precision Link Series
Table-TopIN-CNV-4



Precision Link Series
Heavy-Duty IN-CNV-16

PARTS HANDLERS



LPP Series
Linear Part Handlers IN-PRT-2



RPP Series
Rotary Part Handlers IN-PRT-8

ROTARY PART HANDLER

Features | Table of Contents



Features:

The **CAMCO RPP Cambot® Rotary Parts Handler** is designed for high precision and high capacity. This proven design can be used in a wide variety of industries including automotive, packaging and electronics among others. The RPP can be combined with other CAMCO products such as index drives and precision conveyors for a complete, automated system. The RPP is ideal for pick and place applications with features including:

Rugged and precise cam operated mechanisms engineered for a minimum of 8000 hours of maintenance-free life.

Hardened and ground cams drive both the lift and rotary axes.

Preloaded precision cam followers eliminate backlash and ensure smooth movement.

Preloaded taper roller bearings on the camshaft (Input Shaft).

Four-point contact preloaded roller bearing on the rotary axis.

All bearings are lubricated by an oil bath.

One-piece lift arm.

Ball bushings (recirculating-ball type) support the main lift shaft and turn the large output surface and ride on hardened shafts for stability and stiffness.

Manufactured in a fully integrated application, design, manufacturing and inspection environment.

Table of Contents

How to Order	3
300RPP	5
500RPP	7
Timing Diagrams.....	9

ROTARY PART HANDLER

How to Order

RPP Ordering Procedure

1. Model
2. Rotary Motion (degrees)
 - Oscillator or indexer
 - Oscillator: Home at X or Y
 - Indexer: CW or CCW index
3. Lift (inches)
4. Input Shaft: Side 1, Side 2 or Double Input (DI)
5. Mounting Position: 1-6

Reducer Ordering Procedure

1. Reducer Model, Ratio and Mounting Position
2. Motor Adaptor Model
3. Motor size

Input Shaft Configuration

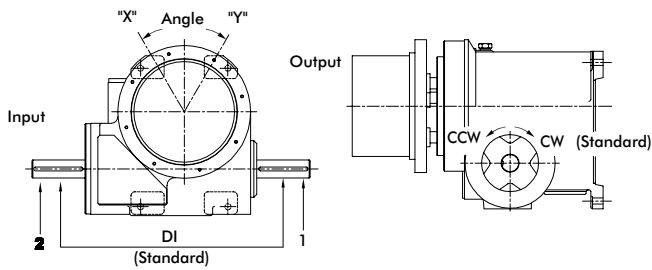

Standard Output Sequence

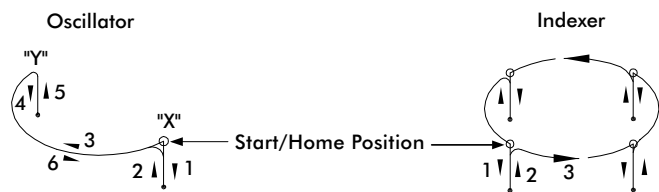

ROTARY PART HANDLER

Mounting Position

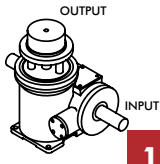
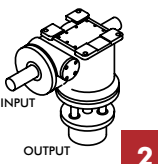
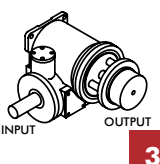
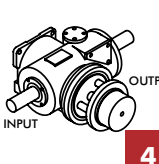
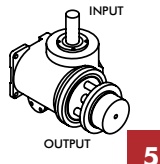
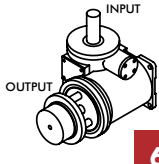
OVOI (output vertical, over input)	OVUI (output vertical, under input)	OHOI (output horizontal, over input)	OHUI (output horizontal, under input)	H-S1-UP (output horizontal, side 1 up)	H-S2-UP (output horizontal, side 2 up)
 1	 2	 3	 4	 5	 6

Gear Reducer Mounting Positions

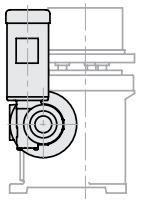
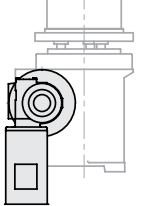
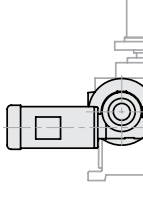
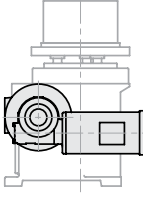
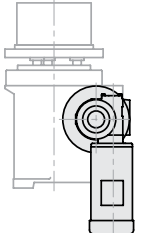
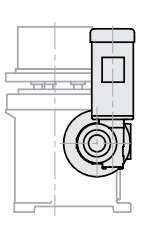
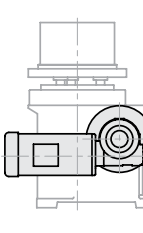
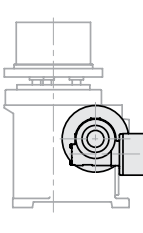
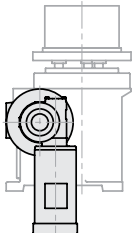
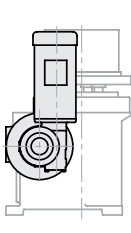
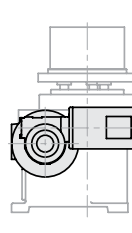
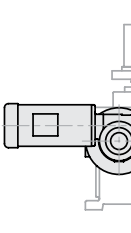
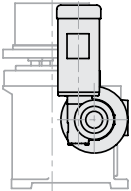
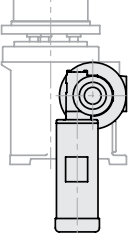
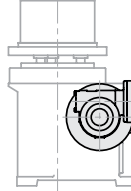
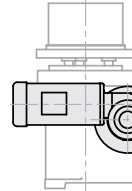
		Mounting "A"		Mounting "B"	
		RH	LH	RH	LH
SIDE 1	 A	 B	 C	 D	
	SIDE 2	 E	 F	 G	 H
		Mounting "C"		Mounting "D"	
		RH	LH	RH	LH
SIDE 1	 J	 K	 L	 M	
	SIDE 2	 N	 P	 R	 S

300RPP SERIES

Rotary Part Handler | Configurations

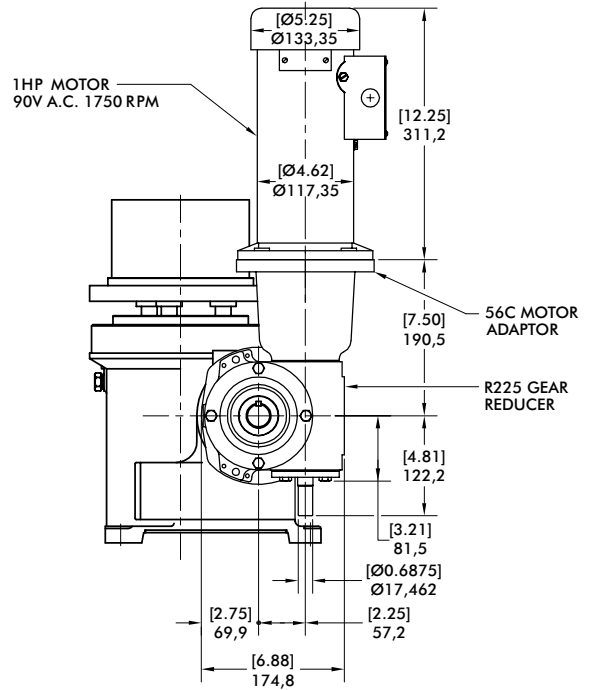
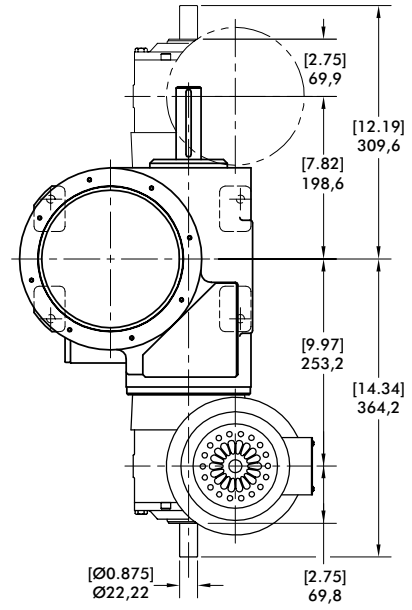
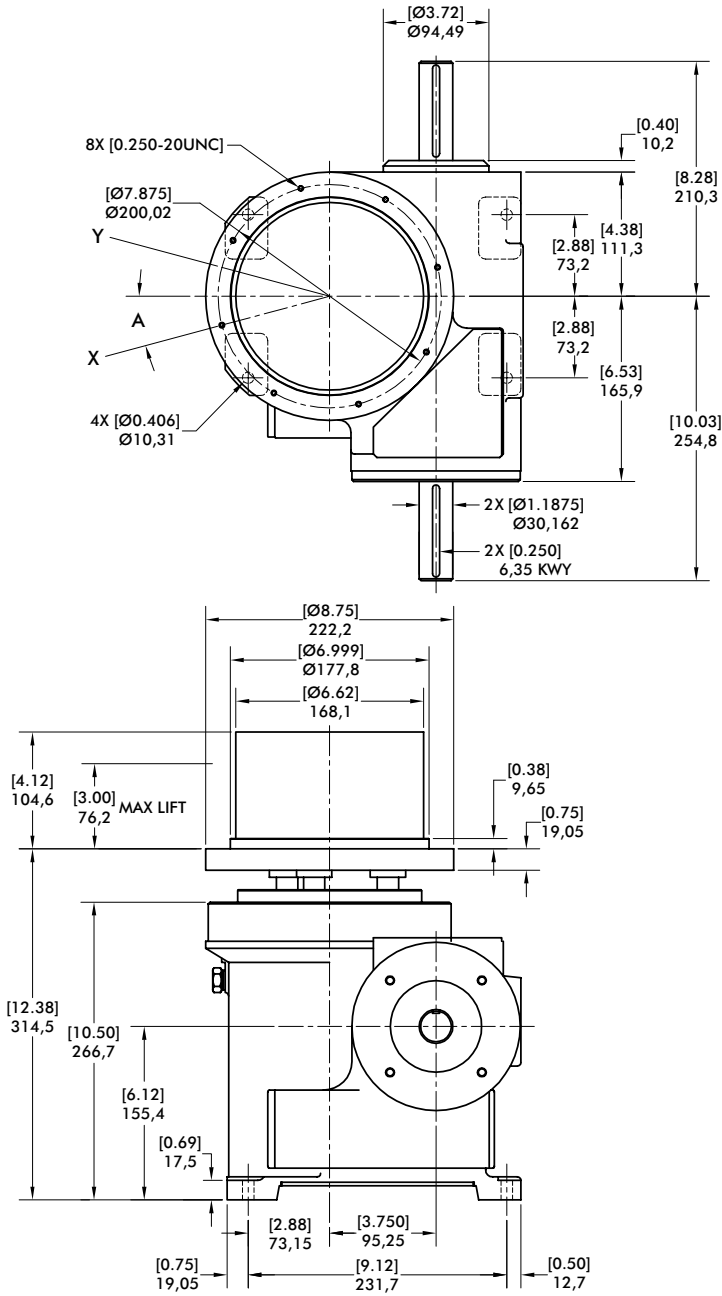

Indexing Motion			
Rotation	Angle A	Lift mm [in]	Model
120°	0°	25,4 [1]	300RPP120H24-1H24
		50,8 [2]	300RPP120H24-2H24
90°	15°	25,4 [1]	300RPP90H24-1H24
		50,8 [2]	300RPP90H24-2H24
		76,2 [3]	300RPP90H24-3H24
60°	0°	25,4 [1]	300RPP60H24-1H24
		50,8 [2]	300RPP60H24-2H24
		76,2 [3]	300RPP60H24-3H24
45°	22.5°	25,4 [1]	300RPP45H24-1H24
		50,8 [2]	300RPP45H24-2H24
		76,2 [3]	300RPP45H24-3H24

Oscillating Motion			
Rotation	Angle A	Lift mm [in]	Model
180°	0°	25,4 [1]	300RPP2H24-1H24
		50,8 [2]	300RPP2H24-2H24
		76,2 [3]	300RPP2H24-3H24
120°	0°	25,4 [1]	300RPP3H24-1H24
		50,8 [2]	300RPP3H24-2H24
		76,2 [3]	300RPP3H24-3H24
90°	0°	25,4 [1]	300RPP4H24-1H24
		50,8 [2]	300RPP4H24-2H24
		76,2 [3]	300RPP4H24-3H24
60°	0°	25,4 [1]	300RPP6H24-1H24
		50,8 [2]	300RPP6H24-2H24

Features

- Standard Indexing or Oscillating Motion
- R225 Reducer (Ratios from 5:1 to 60:1)
— 56C Motor Adapter and Coupling
- 1 HP AC Drive Package with Inverter Duty Motor and Inverter Drive (up to 60 cpm)

Optional Accessories

- 1 HP DC Motor
- Varipak DC Motor Control (up to 30 cpm)

Capacity:*

Maximum Mass	68,04 kg [150 lbm]
Maximum Inertia	4975 kg-cm ² [1700 lb-in ²]

* Note: These values are for speeds of less than 30 rpm, the minimum cam time for rise and rotation, and are for reference only. Each application must be reviewed and approved by CAMCO Engineering.

500RPP SERIES

Rotary Part Handler | Configurations

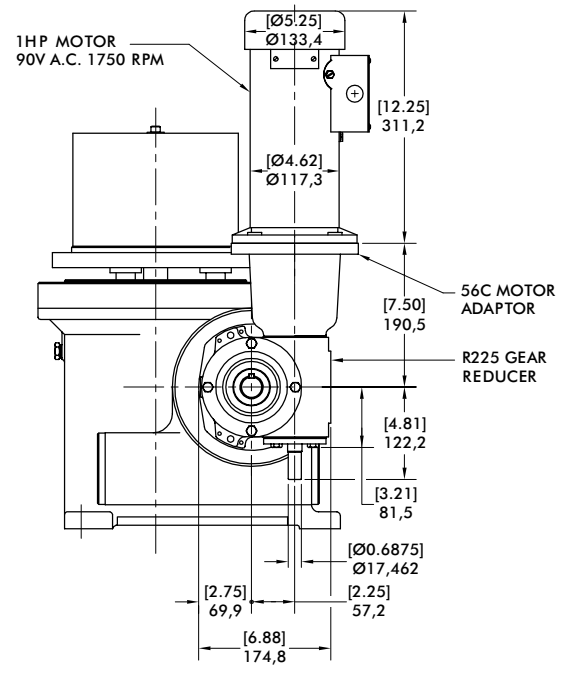
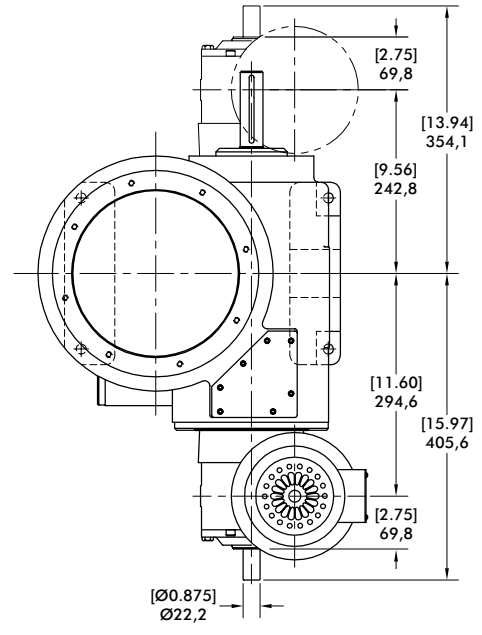
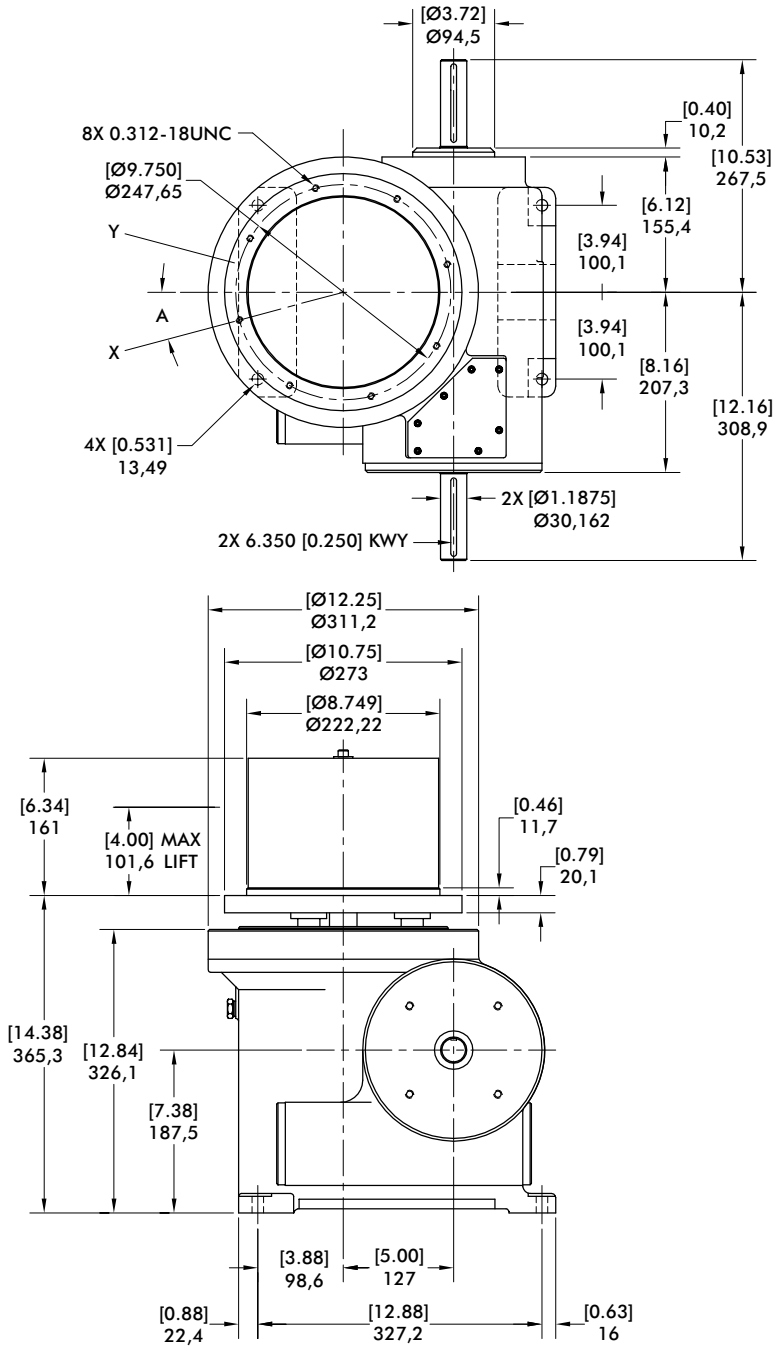

Indexing Motion			
Rotation	Angle A	Lift mm [in]	Model
180°	0°	50,8 [2]	500RPP2H32-2H32
		76,2 [3]	500RPP2H32-3H32
		101,6 [4]	500RPP2H32-4H32
120°	0°	50,8 [2]	500RPP3H32-2H32
		76,2 [3]	500RPP3H32-3H32
		101,6 [4]	500RPP3H32-4H32
90°	0°	50,8 [2]	500RPP4H32-2H32
		76,2 [3]	500RPP4H32-3H32
		101,6 [4]	500RPP4H32-4H32
60°	0°	50,8 [2]	500RPP6H32-2H32
		76,2 [3]	500RPP6H32-3H32
		101,6 [4]	500RPP6H32-4H32

Oscillating Motion			
Rotation	Angle A	Lift mm [in]	Model
120°	0°	50,8 [2]	500RPP120H32-2H32
		76,2 [3]	500RPP120H32-3H32
90°	15°	50,8 [2]	500RPP90H32-2H32
		76,2 [3]	500RPP90H32-3H32
		101,6 [4]	500RPP90H32-4H32
60°	0°	50,8 [2]	500RPP60H32-2H32
		76,2 [3]	500RPP60H32-3H32
		101,6 [4]	500RPP60H32-4H32
45°	22.5°	50,8 [2]	500RPP45H32-2H32
		76,2 [3]	500RPP45H32-3H32
		101,6 [4]	500RPP45H32-4H32

Features

- Standard Indexing or Oscillating Motion
- R225 Reducer (Ratios from 5:1 to 60:1)
— 56C Motor Adapter and Coupling
- 1 hp AC Drive Package with Inverter Duty Motor and Inverter Drive (up to 60 cpm)

Optional Accessories

- 1 hp DC Motor
- Varipak DC Motor Control (up to 30 cpm)

Capacity:*

Maximum Mass	81,65 kg [180 lbm]
Maximum Inertia	9204 kg-cm ² [3145 lb-in ²]

Capacity:*

Maximum Mass	180 lbs
Maximum Inertia	3415 lb-in ²

* Note: These values are for speeds of less than 30 rpm, the minimum cam time for rise and rotation, and are for reference only. Each application must be reviewed and approved by CAMCO Engineering.

ROTARY PART HANDLER

Oscillator Timing Diagram

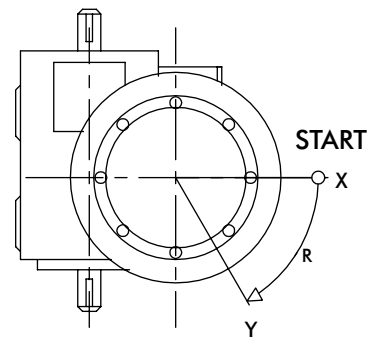
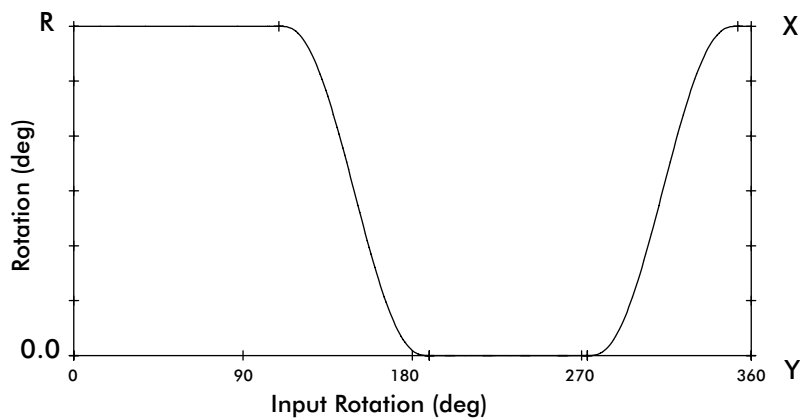
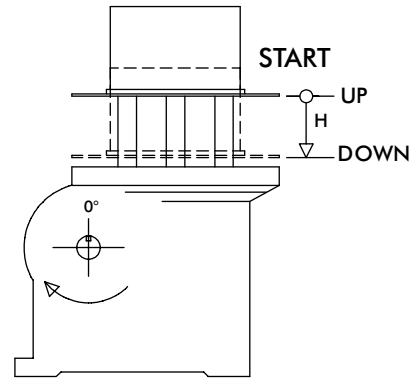
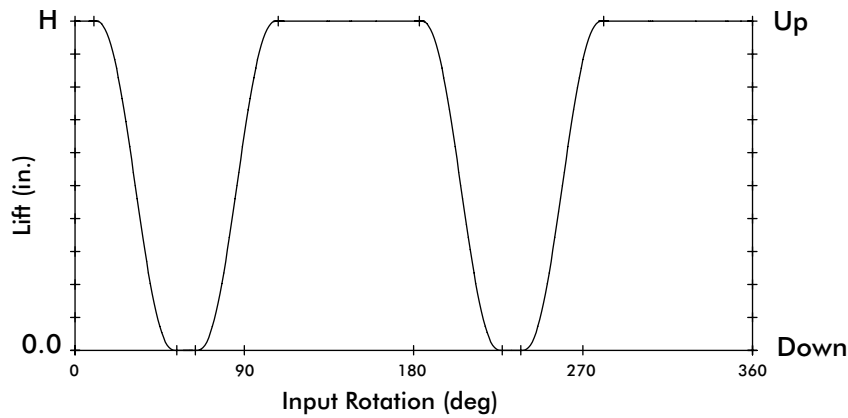

Motion Options

- Standard starting position (home) at time 0 is at maximum rise (up) and at the X rotary position.
- The standard sequence can be mirrored in either the lift, rotary or both:
 - The mirrored lift starts in the zero elevation or down position
 - The mirrored rotary motion starts at Y.
- Custom motion times are also available – consult your Sales Agent for more information.

ROTARY PART HANDLER

Indexer Timing Diagram

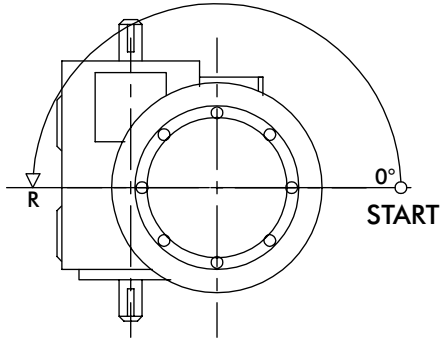
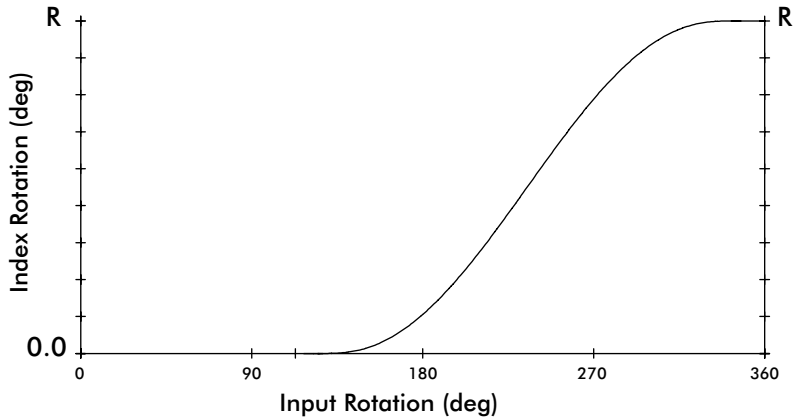
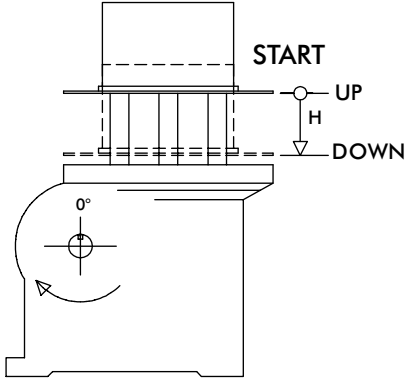
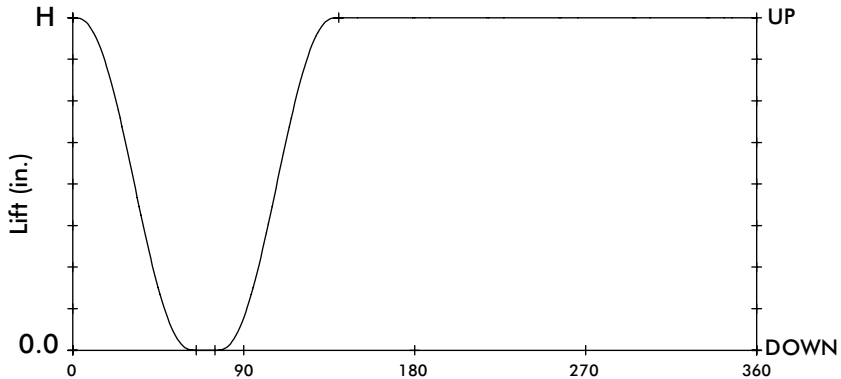

Motion Options

- Standard starting position (home) at time 0 is at maximum rise (up) and at the start of a counter-clockwise index (right-hand cam helix).
- The standard sequence can be mirrored in either the lift, rotary or both:
 - The mirrored lift starts in the zero elevation or down position
 - The mirrored rotary motion is a clockwise index (left-hand helix)
- Custom motion times are also available – consult your Sales Agent for more information.



THE BEST PRODUCTS.
UNMATCHED SERVICE.
WORLDWIDE.

GLOBAL SALES CONTACTS

CORPORATE HEADQUARTERS



US
+1-888-DESTACO
+1-248-836-6700
northamerica@destaco.com



DE
+49-6171-705-0
europe@destaco.com



SP
+34-936361680
spain@destaco.com



PL
+48-506002115
poland@destaco.com



IN
+91-80-41123421-426
india@destaco.com



MX
mexico@destaco.com



FR
+33-4-7354-5001
france@destaco.com



CN
+86-21-6081-2888
china@destaco.com



NL
+31-297285332
benelux@destaco.com



SG
singapore@destaco.com



UK
+44-1902-797980
uk@destaco.com



TH
+66-2-326-0812
asia@destaco.com



CZ
+420-603-577-341
czech@destaco.com



CA
canada@destaco.com