

Termék összefoglalók

10/29/2024

Ez a katalógus a teljes DESTACO portfólió egy része. A teljes terméklista iránt kérjük, érdeklődjön kollégáinknál.

Table of Contents

Grippers, Rotates, Slides	GR-PRO-1
GTB Roller Gear Servo Positioner	IN-SRV-1
RDM Dial Indexers	IN-MCH-1
Automatic Tool Changers (TC)	TC-TCH-1
Sheet Metal Grippers (SG)	SG-TCH-1
Manual Clamps	MC-PRO-1
Power Clamps (PC)	PC-PRO-1

Table of Contents (continued)

GRIPPERS/SLIDES/ROTARIES

Table of Contents

Introduction:

North American Xpress Program	GR-PRO-2
European Xpress Program	GR-PRO-3
Clean Room Solutions.....	GR-PRO-6
Robotic Tooling Solutions	GR-PRO-7
Modular Mounting Solutions/DirectConnect™	GR-PRO-11
Product Sizing and Application Charts	GR-TCH-1



Electric Grippers GR-EPG



Precision Grippers GR-PRC



General Industrial Grippers .. GR-GEN



Heavy Duty GrippersGR-HDP



OEM Machine Builder.....GR-OEM



3-Jaw Parallel Grippers GR-3JP



Angular Grippers..... GR-ANG



Specialty Grippers GR-SPC



Rotary Actuators GR-ROT



Linear Slides..... GR-LIN

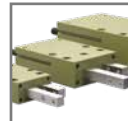

Feed Escapements..... GR-ESC

NORTH AMERICAN XPRESS PROGRAM

A Full Line of Automation Products to Meet Your Application Needs Quickly













ON OUR MOST POPULAR PRODUCTS

To choose the best and most cost-effective automation solution for your application please contact your DESTACO sales representative or DESTACO customer service.

Product listed below are for North American Market only.

Parallel Grippers

		 SIZE	 STROKE [mm]	 FORCE [N]
	HEAVY DUTY RDH/RTH Series 2 & 3 Jaw Impact Resistant Shielded Gripper	1, 2, 3, 4, 5 -L Stroke option	4.0-26	125-675
	HEAVY DUTY RP Series Rugged Impact Resistant Gripper	5, 10, 11, 12, 15	4.0-12.7	156-311
	RPL/RPLC Series Zero Side Play, High Repeatability Gripper	1, 2, 3, 4 (C)=Clean Room Version	6.4-25.4	116-160
	RPM/RPMC Series Low Friction Micro Gripper	1, 2, 3, (C)=Clean Room Version	4.1-6.3	36
	DPG Series Modular Multi-Part Sensing Gripper	10M-2	12.7	222
	HEAVY DUTY DPW Series Wide Parts/ Long Finger Gripper	250, 375, 500	19.05-63.5	222-800
	HEAVY DUTY RPW Series Wide Parts/ Long Finger Gripper	625	50.8-88.9	1068

Angular Grippers

		 SIZE	 ANGLE	 FORCE [N]
	RA Series Low Cost Small Size Angular Gripper	RA-5	15° (per finger)	89

Rotary Actuators

		 SIZE	 ANGLE	 PAYLOAD [Kg]
	RR Series High Torque Compact Rotary Actuators	18, 28, 36	0-180°	0.45-3.6

EUROPEAN XPRESS PROGRAM

A Full Line of Automation Products to Meet Your Application Needs Quickly



ON OUR MOST POPULAR PRODUCTS

To choose the best and most cost-effective automation solution for your application please contact your DESTACO sales representative or DESTACO customer service.

Product listed below are for European Market only.



SIZE















STROKE [mm]



FORCE [N]

2-Jaw Parallel Grippers

		SIZE	STROKE [mm]	FORCE [N]
	HEAVY DUTY RDH Series Impact Resistant Shielded Gripper	All Sizes	4-70	361-28002
	2P Series Precision Cylindrical Gripper	All Sizes	10-30	109-3043
	REP-2 Series Cylindrical Shielded Gripper	All Sizes	10-30	480-3351
	DGC Series Precision Long Stroke Gripper	All Sizes	20-60	474-2318
	DPG Series Modular Gripper	All Sizes	6.4-25.4	222
	DPW Series Wide Parts/ Long Finger Gripper	All Sizes	19.1-63.5	222-800
	HEAVY DUTY RPW Series Wide Parts/ Long Finger Gripper	625, 750	19.1-114.3	222-2091
	HEAVY DUTY RP Series Rugged Impact Resistant Gripper	All Sizes	4.0-50.8	40-3336
	DPL Series Long Stroke, Low Profile Gripper	All Sizes	40-140	811-2035
	CP Series Compact Gripper	All Sizes	4-32	10-2749
	RPL/RPLC Series Zero Side Play, High Repeatability Gripper	All Sizes (C)=Clean Room	6.4-25.4	116-160
	RPM/RPMC Series Low Friction Micro Gripper	All Sizes (C)=Clean Room	3.2-6.3	36
	RDE Series Water Immersion Gripper	Contact DESTACO for More Information		

EUROPEAN XPRESS PROGRAM

A Full Line of Automation Products to Meet Your Application Needs Quickly











ON OUR MOST POPULAR PRODUCTS







To choose the best and most cost-effective automation solution for your application please contact your DESTACO sales representative or DESTACO customer service.

Product listed below are for European Market only.

3-Jaw Parallel Grippers

		 SIZE	 STROKE [mm]	 FORCE [N]	
    	HEAVY DUTY	RTH Series Impact Resistant Shielded Gripper	All Sizes	4-20	579-4562
		3P Series Precision Cylindrical Gripper	All Sizes	10-30	107-2030
		REP-3 Series Cylindrical Shielded Gripper	All Sizes	10-30	469-3268
		PPC Series Thru-Hole Gripper	All Sizes	10-30	896-4332
		RTE Series Water Immersion Gripper	Contact DESTACO for More Information		

Angular Grippers

		 SIZE	 ANGLE	 FORCE [N]	
   		RUA Series Cylindrical Gripper	All Sizes	15.9-19.1° (per finger)	313-3941
		DCT-CT Series 180° Jaw Opening Gripper	All Sizes	90° (per finger)	32-893
		RA Series Compact Gripper	RA-6	15° (per finger)	71-801
		FUA Series Food Gripper	All Sizes	35° (per finger)	9-32

EUROPEAN XPRESS PROGRAM

A Full Line of Automation Products to Meet Your Application Needs Quickly



ON OUR MOST POPULAR PRODUCTS

To choose the best and most cost-effective automation solution for your application please contact your DESTACO sales representative or DESTACO customer service.

Product listed below are for European Market only.

Rotary Actuators



SIZE



ANGLE



PAYLOAD [Kg]



RR Series Light-Duty
High Torque Compact
Rotary Actuators

All Sizes

0-180°

0.45-1.3



RR Series Heavy-Duty
High Torque Compact
Rotary Actuators

All Sizes

0-180°

3.6-91

Feed Escapements



SIZE



STROKE [mm]



PARTS ESCAPED

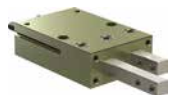

RFE Series
2-Finger Actuation

All Sizes

16-32

85-150
(per minute)

Tool Changers and Compliance



SIZE



PORTS



PAYLOAD [Kg]



RQC/RTP Series
Heavy-Duty
Tool Changer

All Sizes

19 pin
Electrical and
6 Pneumatic
Ports

90-550



QC/TP Series
Tool Changer

All Sizes

12-15 pin
Electrical and
4 Pneumatic
Ports

30-150

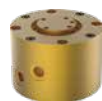

CH Series
Horizontal Compliance

All Sizes

N/A

2-40



AU Series
Resettable Emergency
Stop Module

Contact DESTACO for More Information

CLEAN ROOM RATED SOLUTIONS

Grippers/Slides/Rotaries | Product Overview

DESTACO's Clean Room Rated Solutions are geared toward laboratory, semiconductor, medical, and food handling type environments. Many of our pneumatic products include a scavenge or purge port. These extra ports create internal vacuum or pressure to control contaminants escaping into the environment or prevent de-greaser or other chemicals penetrating our product.

Solutions include:

- Diverse line-up of products for class 10/100 cleanroom environments
- Manufactured with corrosion-resistant materials for use with de-ionized water
- Customized solutions available with food and medical grade lubricants, stainless steel, and nickel-plated materials to meet your application requirements.

Electric Parallel Grippers			
Rating	RPE-100	DPE-200	DPE-400
ISO 4 (Class 10)	☉☉		
ISO 5 (Class 100)	☉		☉
ISO 6 (Class 1,000)	☉	☉	☉
ISO 7 (Class 10,000)	☉	☉	☉
ISO 8 (Class 100,000)	☉	☉	☉

Pneumatic 2-Jaw and 3-Jaw Grippers									
Rating	RPMC	RPLC	DPDS	DPDL	DPG	DPP	RDH	RTH	DCT
ISO 4 (Class 10)	☉☉	☉☉	☉☉						
ISO 5 (Class 100)	☉☉☉	☉☉☉	☉☉☉	☉☉☉	☉		☉☉	☉☉	☉
ISO 6 (Class 1,000)	☉☉☉	☉☉☉	☉	☉	☉		☉	☉	☉
ISO 7 (Class 10,000)	☉	☉	☉	☉	☉	☉	☉	☉	☉
ISO 8 (Class 100,000)	☉	☉	☉	☉	☉	☉	☉	☉	☉

Linear Slides			
Rating	DLB	DLT	DLM
ISO 4 (Class 10)			
ISO 5 (Class 100)			
ISO 6 (Class 1,000)	☉	☉	☉
ISO 7 (Class 10,000)	☉	☉	☉
ISO 8 (Class 100,000)	☉	☉	☉

Rotaries	
Rating	RR
ISO 4 (Class 10)	
ISO 5 (Class 100)	
ISO 6 (Class 1,000)	
ISO 7 (Class 10,000)	
ISO 8 (Class 100,000)	☉

- ☉ Standard Clean Room
- ☉☉ With use of Scavenge Port

Note: All products tested using Krytox™ Grease. Please contact factory for individual test results and additional clean room requirements.

ROBOTIC TOOLING SOLUTIONS

CLICK OR SCAN
To view full catalog pages
on these product

Automatic Tool Changers | Features and Benefits

Automatic Tool Changers

Robotic Applications:

Perfect for those flexible/multiple tooling applications utilizing one Robot. This product was designed with exceptional repeatability, high rigidity & load capacity to make it ideal for any robotic application.

Automation Applications:

End effector tooling and interchangeable fixturing can be changed quickly and easily to accommodate many different styles of parts on the same assembly machine or machining center.

Highly Configurable, Modular Design (RQC/RTP):

The Modular RQC series easily accommodates up to (4) optional modular interfaces, offering a high level of flexibility.

Mounting Information

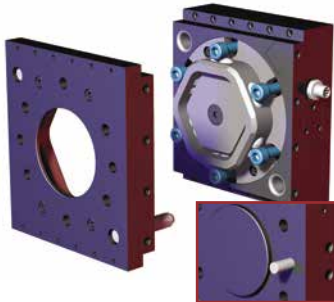

RQC Robot Plate Adaptor
Counterbored holes for mounting with a dowel pin hole, a raised boss for location and a ISO9409-1 mounting pattern.

Back Side of RQC

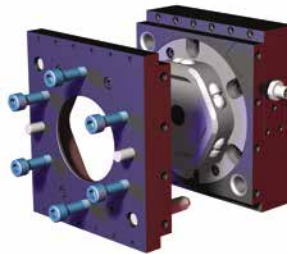

RTP Tool Plate Adaptor
Tapped holes, two dowel pin holes for accurate location of payload and a ISO9409-1 mounting pattern.



QC Robot Plate Adaptor
has counterbored holes for mounting and two dowel pins for hole location (size 30 has pilot boss).



TP Tool Plate Adaptor
has counterbored holes for mounting and two dowel pins for hole location (size 30 has pilot boss).



RHC Robot Plate Adaptor
mounts with screws from behind or through the front and locates with dowel pins for accuracy.



RHC Tool Plate Adaptor
mounts payload with screws from behind or through the front and locates with dowel pins for accuracy. Protect cone surfaces from debris to insure proper positioning.



Compliance Device | Features and Benefits

Flexibility of the Tool:

Cylindrical Horizontal compliance devices are used for inserting components that may be misaligned with the tool. They allow a horizontal displacement that compensates for part placing inaccuracies.

For Precision Applications:

High quality components allows for centering repeatability from 0.02mm and angular repeatability from $\pm 10^\circ$.

Harsh Environments:

Enclosed design allows them to be used in harsh environments.

Spring Assist:

Optional spring assist allows for use in single acting mode.



Mounting Information



CH Horizontal Compliance
The compliance is located using a pilot boss and a dowel pin and assembled using 4 or 6 through body screws.

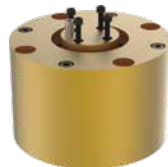

Tool Mounting
Tooling is located using a centering and a dowel pin and assembled using 4 screws.



See pages 2-5 for product availability in your region.



CLICK OR SCAN

To view full catalog pages on this product

RQC/RTP SERIES

Automatic Tool Changers | Technical Information



See pages 2-5 for product availability in your region.

RQC-200/RTP-200

Combined Weight: 3 Kg [6.7 lb]
Max. Payload: 90 Kg [200 lb]
Max. Moment: 810 Nm [7200 in-lb]

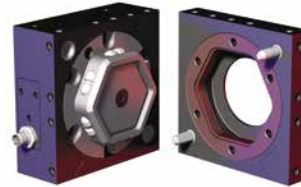
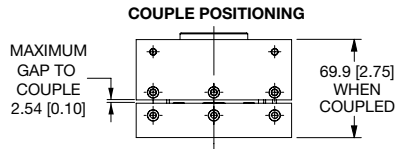

RQC-200 Robot Plate
RTP-200 Tool Plate

RQC-400/RTP-400

Combined Weight: 4.7 Kg [10.4 lb]
Max. Payload: 180 Kg [400 lb]
Max. Moment: 1580 Nm [14000 in-lb]

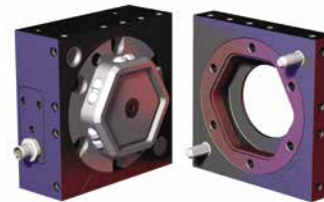
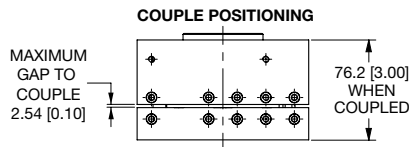

RQC-400 Robot Plate
RTP-400 Tool Plate

RQC-800/RTP-800

Combined Weight: 7.1 Kg [15.8 lb]
Max. Payload: 360 Kg [800 lb]
Max. Moment: 2490 Nm [22000 in-lb]

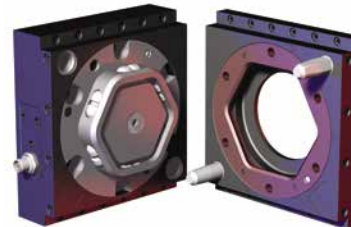
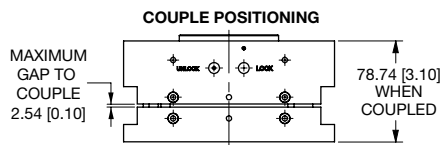

RQC-800 Robot Plate
RTP-800 Tool Plate

RQC-1200/RTP-1200

Combined Weight: 8.3 Kg [18.4 lb]
Max. Payload: 550 Kg [1200 lb]
Max. Moment: 3390 Nm [30000 in-lb]

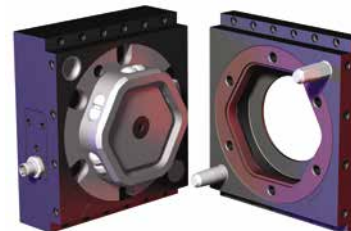
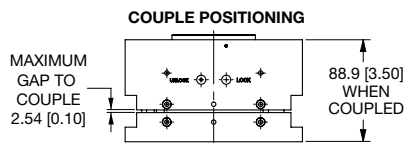

RQC-1200 Robot Plate
RTP-1200 Tool Plate

RQC-2400/RTP-2400

Combined Weight: 30 Kg [66.1 lb]
Max. Payload: 1089 Kg [2400 lb]
Max. Moment: 7000 Nm [61955 in-lb]

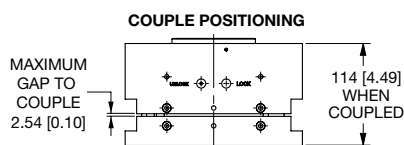

RQC-2400 Robot Plate
RTP-2400 Tool Plate

QC/TP, RHC SERIES

CLICK OR SCAN
To view full catalog pages
on these product

Automatic Tool Changers | Features and Benefits

QC Series Tool Changers



See page 2-5 for
product availability
in your region.



RHC Series Tool Changers



QC-30
Robot
Plate



TP-30
Tool
Plate

Combined Weight: 0.34 Kg [0.75 lbs]
Max. Payload: 13.6 Kg [30 lbs]
Max. Moment: 22.6 Nm [200 in-lbs]

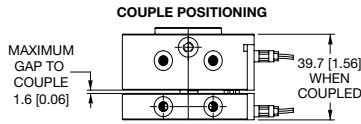

RHC-1-R
Robot
Plate



RHC-1-T
Tool
Plate

Combined Weight: 0.29 Kg [0.63 lbs]
Max. Payload: 9 Kg [20 lbs]
Max. Moment: 28 Nm [250 in-lbs]

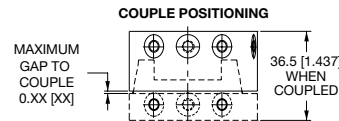

QC-60
Robot
Plate



TP-60
Tool
Plate

Combined Weight: 1.27 Kg [2.8 lbs]
Max. Payload: 27 Kg [60 lbs]
Max. Moment: 88.1 Nm [780 in-lbs]

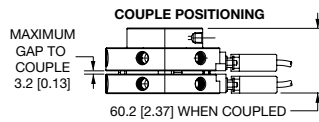

RHC-2-R
Robot
Plate



RHC-2-T
Tool
Plate

Combined Weight: 0.82 Kg [1.81 lbs]
Max. Payload: 59 Kg [130 lbs]
Max. Moment: 136 Nm [1200 in-lbs]

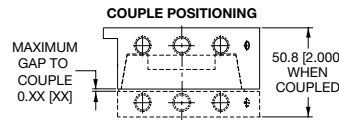

QC-60-10P
Robot
Plate



TP-60-10P
Tool
Plate

Combined Weight: 1.27 Kg [2.8 lbs]
Max. Payload: 27 Kg [60 lbs]
Max. Moment: 88.1 Nm [780 in-lbs]

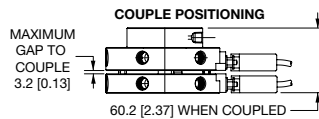

RHC-4-R
Robot
Plate



RHC-3-T
Tool
Plate

Combined Weight: 3.1 Kg [6.8 lbs]
Max. Payload: 136 Kg [300 lbs]
Max. Moment: 1017 Nm [9000 in-lbs]

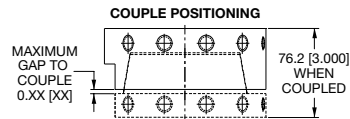

QC-150
Robot
Plate



TP-150
Tool
Plate

Combined Weight: 3.2 Kg [7.1 lbs]
Max. Payload: 68 Kg [150 lbs]
Max. Moment: 215 Nm [1900 in-lbs]

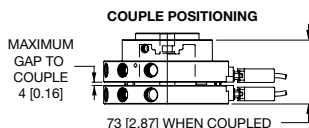

RHC-4-R
Robot
Plate



RHC-4-T
Tool
Plate

Combined Weight: 11 Kg [24.3 lbs]
Max. Payload: 454 Kg [1000 lbs]
Max. Moment: 2825 Nm [25000 in-lbs]

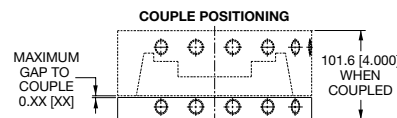

ROBOTIC TOOLING SOLUTIONS

Tool Changer Docking Station

DESTACO offers custom and standard Docking Stations to fit customers needs. Please contact DESTACO Sales for more information.

Key Features:

- Allows for quick changing of tooling
- Reducing machine down-time
- Safely stores tooling when not in use
- Standard or custom stations

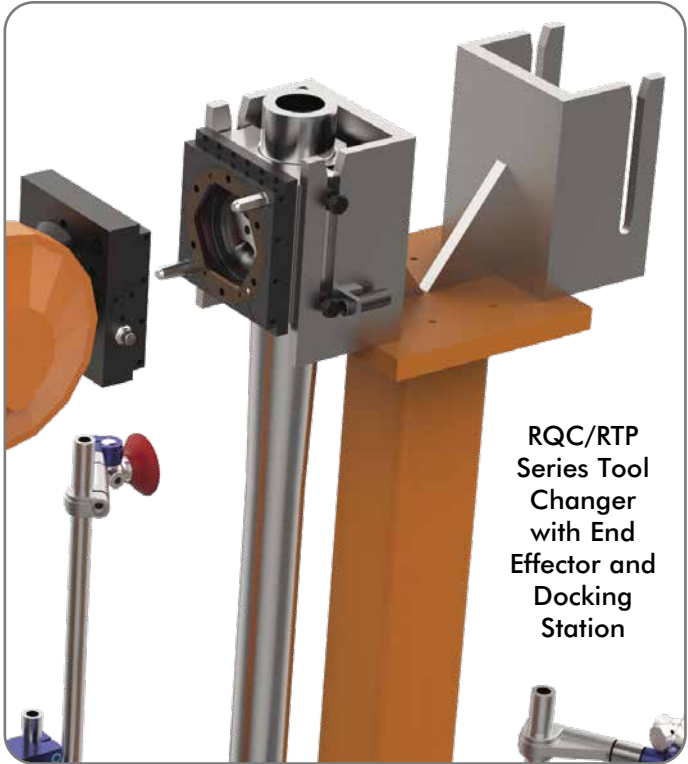
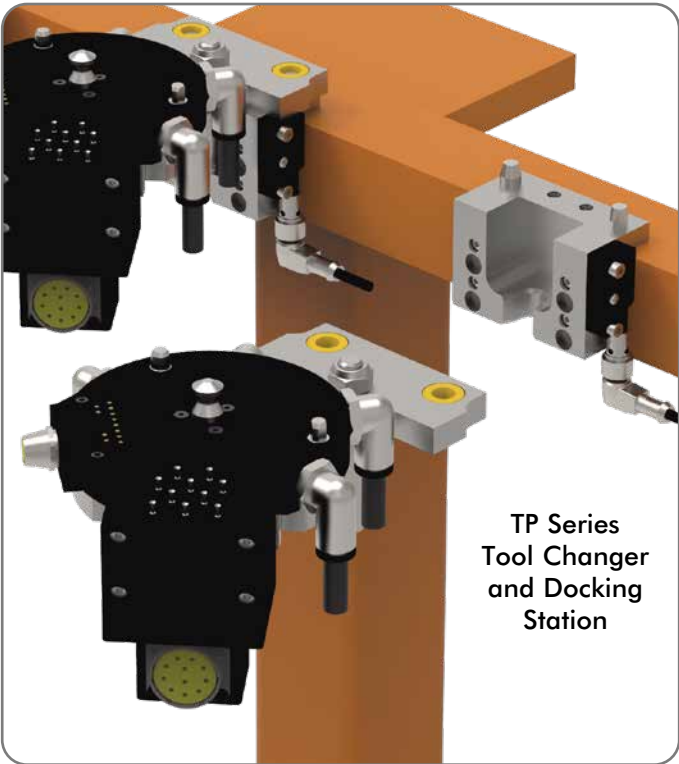
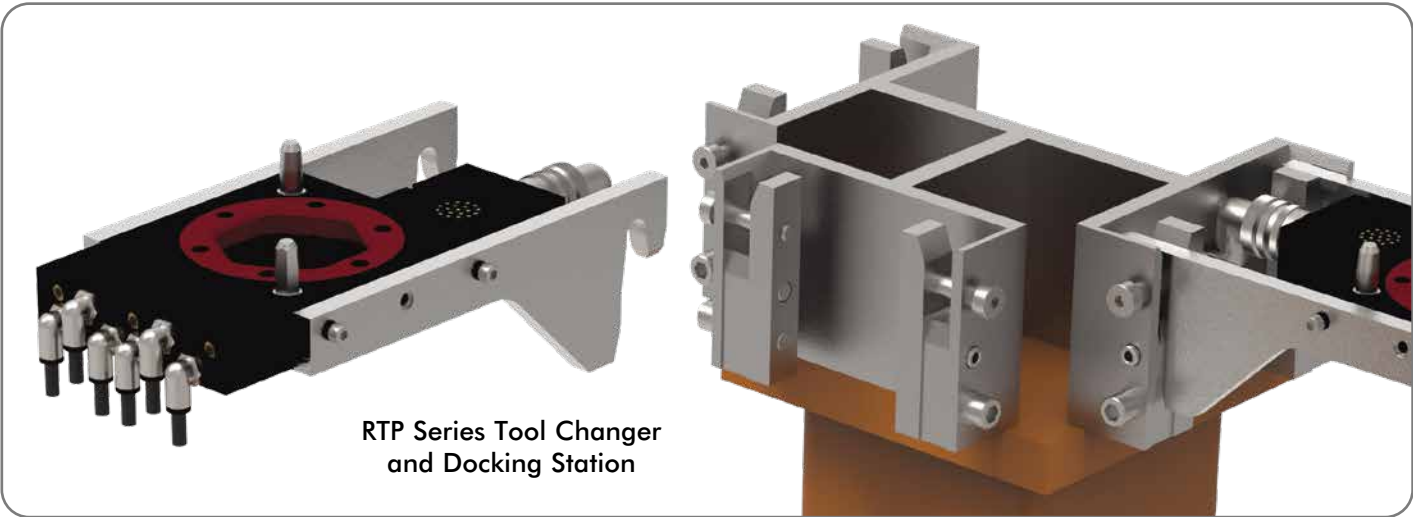

MODULAR MOUNTING SOLUTIONS

Grippers/Slides/Rotaries | Product Overview

DESTACO's modular automation systems feature DIRECTCONNECT™ technology, allowing all components of the system—base slides, block thrusters, thruster slides, grippers, and mounting stanchions—to be mounted together quickly and easily without any adapter plates.

- Reduces engineering design
- Saves \$\$\$ with modular solutions
- Change device orientations quickly
- Eliminates Adapter Plates

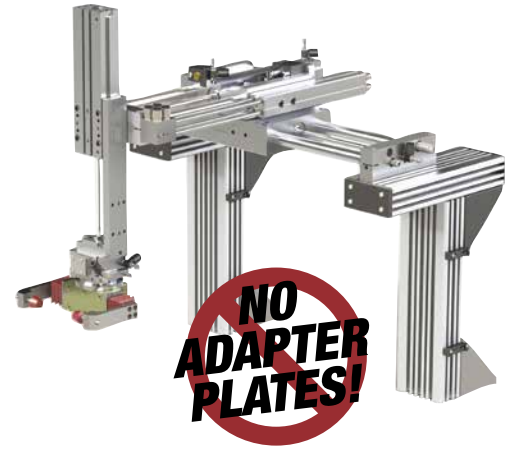

Modular DIRECTCONNECT Mounting Style Examples:

Look for more examples of each main section of the catalog. This is a sample of configurations we offer. Custom solutions also available.

Rotate & Place

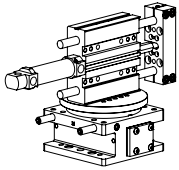

DRF Rotary Actuator
to DLT Linear Slide

Pick & Place

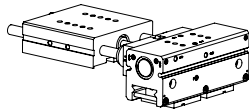

DLT Base Slide to
DPP Parallel Gripper

Place & Place

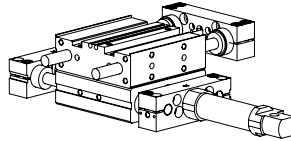

DLB Base Slide to
DLT Linear Slide

Place & Place

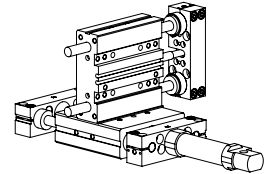

DLB Base Slide to
DLT Linear Slide

Connect Different Sizes & Styles

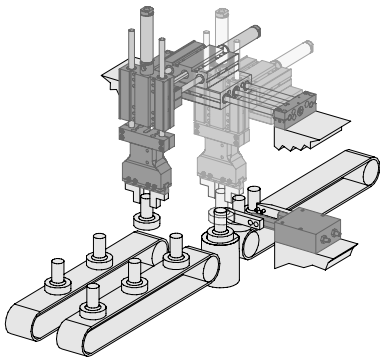

Configure in Multiple Orientations

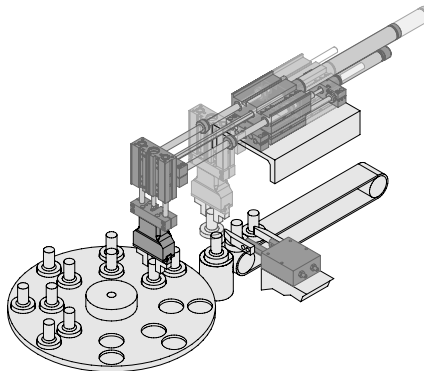

Look for the DIRECTCONNECT Logo

Product Series beginning with the letter D have a DIRECTCONNECT option, with a few exceptions.

DIRECTCONNECT™

HOW TO MAKE A DIRECTCONNECT™ MOUNT

Grippers/Slides/Rotaries | Product Overview

The DIRECTCONNECT Modular Compatibility Chart (on the next page) shows all the products that can easily connect together without adapter plates. Simply locate your first product along the horizontal axis of the top of chart, then locate the second product along the vertical axis on the left side of the chart. If a connection can be made, a mounting pattern will be shown.

DIRECTCONNECT Modular Compatibility Example:

Shown below, a DLB-10,12,16 Base Slide connecting to a DLT-10,12,16 Linear Thruster. Units may connect on different faces of the unit. Please refer to individual datasheets for DIRECTCONNECT mounting surfaces.

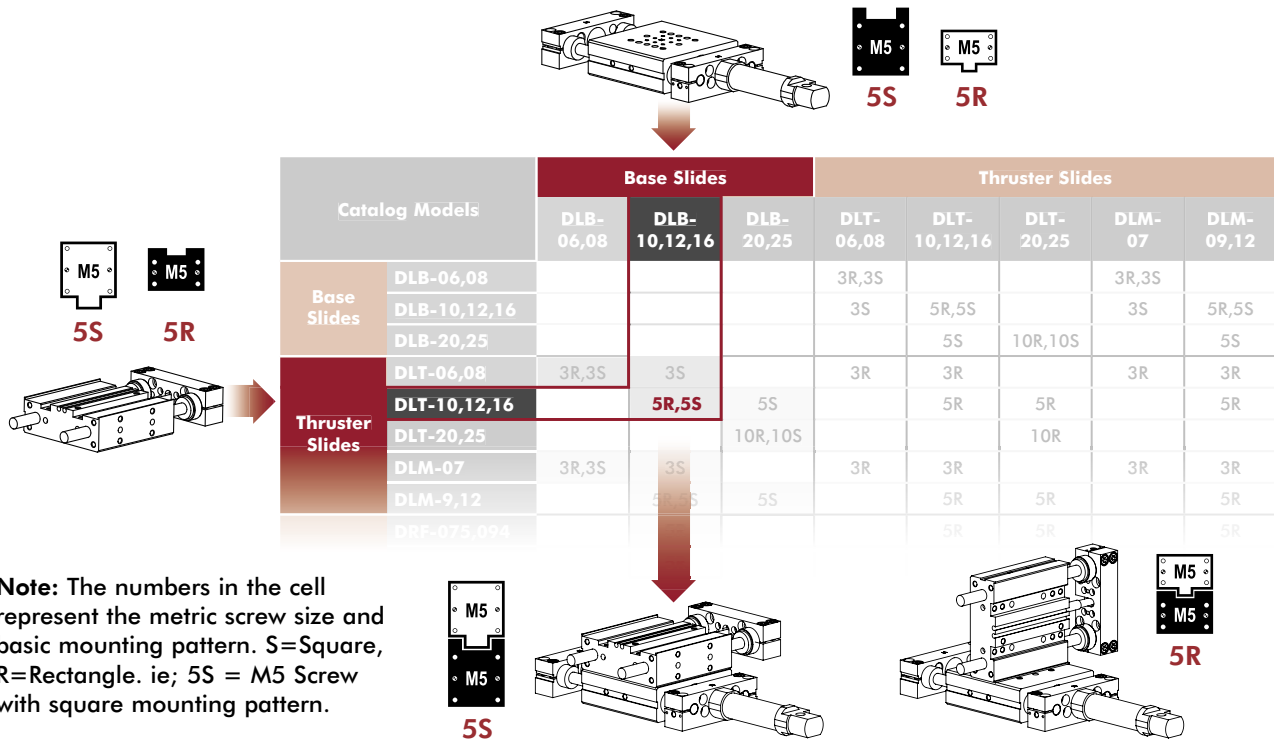

DirectConnect Mounting Surface Example:

Locate matching DIRECTCONNECT mounting pattern icons on the products dimensional drawings to determine what surface faces can be connected to. Corresponding mates equal a DIRECTCONNECT connection.

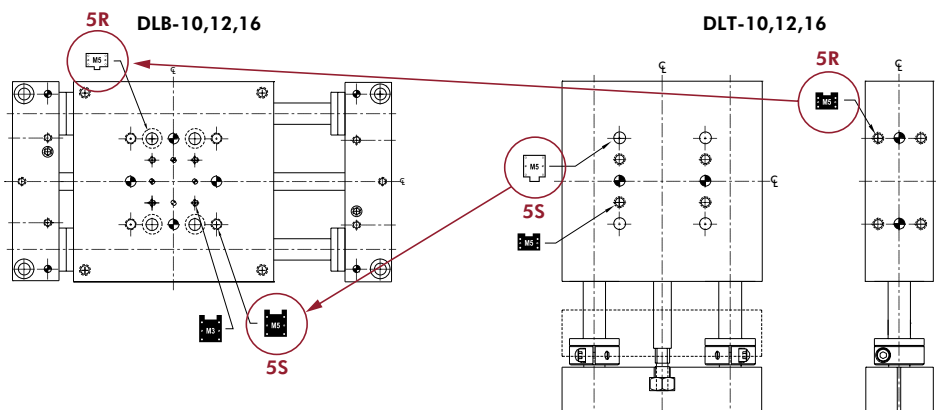

DIRECTCONNECT™ MODULAR COMPATIBILITY CHART

Grippers/Slides/Rotaries | Product Overview

DESTACO's modular automation systems feature DirectConnect™ technology, allowing all components of the system—base slides, block thrusters, thruster slides, and grippers—to be mounted together quickly & easily without any adapter plates. Look for matching icons on product datasheets for mounting compatibility.

Simply locate your first product along the horizontal axis of the top of chart, then locate the second product along the vertical axis on the left side of the chart. If a connection can be made, a mounting pattern will be shown.

Note: The numbers in the cell represent the metric screw size and basic mounting pattern. S=Square, R=Rectangle. ie; 5S = M5 Screw with square mounting pattern.

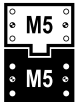
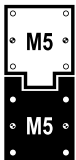

M5 (S)quare M5 (R)ectangle

Catalog Models		Base Slides		
		DLB-06&08	DLB-10,12&16	DLB-20&25
Base Slides	DLB-06 & 08			
	DLB-10, 12 & 16			
	DLB-20 & 25			
Thruster Slides	DLT-06 & 08	3R,3S	3S	
	DLT-10, 12 & 16		5R,5S	5S
	DLT-20 & 25			10R,10S
	DLM-07	3R,3S	3S	
	DLM-9 & 12		5R,5S	5S
Grippers	DGC		5R	
	DPG		5R	
	DCT-12, 16 & 25	3R		
	DCT-25		5R	
	DPDL-047 & 056	3R		
	DPDL-088 & 125		5R	
	DPDL-175 & 250			10R
	DPDS-047 & 056	3R		
	DPDS-088 & 125		5R	
	DPDS-175 & 250			10R
	DPL-25xx		5R	
	DPL-32xx & 40xx			10R
	DPP-10 & 14	3R		
	DPP-20		5R	
	DPP-28		5R	10R
	DPW-250	3R		
	DPW-375 & 500		5R	
	G110-08 & 011	3R		
G110-18 & 25		5R		
DPE-200		5R		
DPE-400			10R	

DIRECTCONNECT™ MODULAR COMPATIBILITY CHART

Grippers/Slides/Rotaries | Product Overview

Thruster Slides				
DLT-06&08	DLT-10,12&16	DLT-20&25	DLM-07	DLM-09&12
3R,3S			3R,3S	
3S	5R,5S		3S	5R,5S
	5S	10R,10S		5S
3R	3R		3R	3R
	5R	5R		5R
		10R		
3R	3R		3R	3R
	5R	5R		5R
	5R	5R		5R
3R	3R		3R	3R
	5R	5R		5R
3R	3R		3R	3R
	5R	5R		5R
		10R		
3R	3R		3R	3R
	5R	5R		5R
		10R		
	5R	5R		5R
		10R		
3R	3R		3R	3R
	5R	5R		5R
	5R	10R		5R
3R	3R		3R	3R
	5R	5R		5R
3R	3R		3R	3R
	5R	5R		5R
	5R	5R		5R
		10R		

GTB SERIES

Globoidal (Roller Gear) Servo Positioner | Table of Contents



Features:

Destaco's **CAMCO GTB Series** are lightweight, compact, high-accuracy programmable servo positioners.

The exceptional low profile high-torque output design supports the demands of high inertia load applications.

Available in four sizes, the GTB series units are lubricated for life and can be mounted in either horizontal or vertical orientations. The GTB Series feature the largest utility through hole diameter available for its size, making it ideal for space constrained machine applications.

Table of Contents

IN-SRV-#

Features & Benefits	2
How to Order	3
Specifications	5
Indexer Sizing	6
GTB40	7
GTB63	10
GTB80	13
GTB100	16

Zero Backlash Roller Gear Cam Mechanism

Innovative roller gear design provides exceptionally smooth motion performance. The globoidal cam and output turret with integrated rollers are a preloaded system that delivers zero backlash for superior accuracy, stiffness and long term durability.

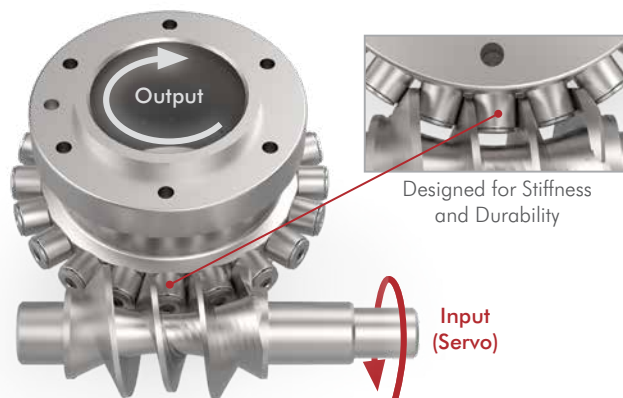

Flexible Drive Options

Each GTB model can be ordered in two different drive options. The high-torque gear drive option is used for applications with large inertia requirements while maintaining a small motor size. The direct drive option provides zero backlash, high precision operation. Both options interface with an array of servo motor suppliers.

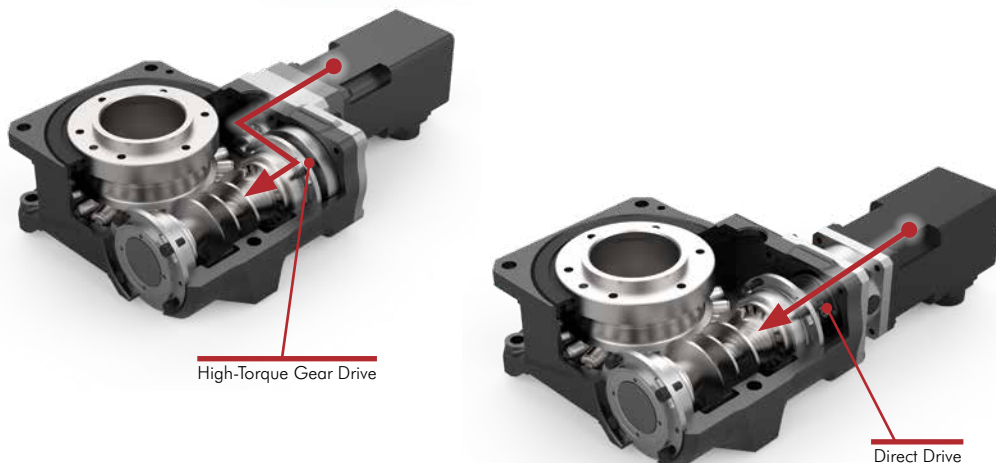

Orientation Independent Mounting

GTB Series units can be mounted in any orientation for easy installation and machine standardization.

Install units in any configuration:

- Flat horizontal table mounting
- Vertical mounting
- Trunnion Mounting
- Inverted (upside down) mounting



GTB SERIES

Globoidal (Roller Gear) Servo Positioner | How To Order

GTB Series: How To Order

Globoidal (Roller Gear) Servo Positioner Base Unit

GTB Series units can be interfaced with wide variety of servo motor manufacturers. Use the MI code tables to identify the supported motors for each GTB unit. The MI code specifies the motor adapter plate that provides direct easy motor mounting to the GTB servo positioner.

The -H option for independent mounting orientation comes standard with every GTB series unit. The -T option for precision dial plate locating dowel hole and -B option for precision mounting dowel holes are also provided as standard.



GTB Series without motor installed

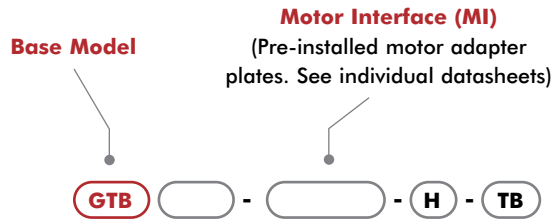

Size	Supported Gear Ratios
40	45:1
	15:1
63	60:1
	20:1
80	60:1
	20:1
100	60:1
	20:1

Standard Features

- H** Orientation independent mounting. Supports vertical, horizontal, trunnion applications
- T** Single output flange surface dowel hole for precision dial plate locating
- B** Precision placement housing dowel holes, 2 on top of unit, 2 on bottom of unit

Easily Integrates with a Variety of Servo Motor Manufacturers

Allen Bradley	Mitsubishi
AMK	Panasonic
Mitsubishi	Sanyo
FANUC	SEW
Keyence	Siemens
KUKA	Yaskawa

Units are available in two different gear ratios based on Direct or Geared motor coupling. Contact Sales to determine what motors are supported for precision direct drive applications and geared drive high torque configurations.



Gear Drive:
High Inertia Applications
 45:1 GTB40
 60:1 GTB63, GTB80, GTB100



Direct Drive:
Zero Backlash Precision Applications
 15:1 GTB40
 20:1 GTB63, GTB80, GTB100

GTB Series: How to Order configured System (Allen Bradley only)

Servo Positioner Configured Systems

GTB Series units can be interfaced with wide variety of servo motor manufacturers. Use the MI code table to identify the supported motors for each GTB unit.

GTB series are also offered as a configured system when selecting Allen Bradley servo motors. The Allen Bradley servo motor will be installed to the GTB unit and shipped as a complete assembly. The GTB series and motor combinations are a matched pair that supports a variety of servo positioning rotary table applications. To use one of the configured systems you must verify the application requirements are within the operating parameters of the GTB unit and motor combination.



GTB Series with Allen Bradley Motor Installed*

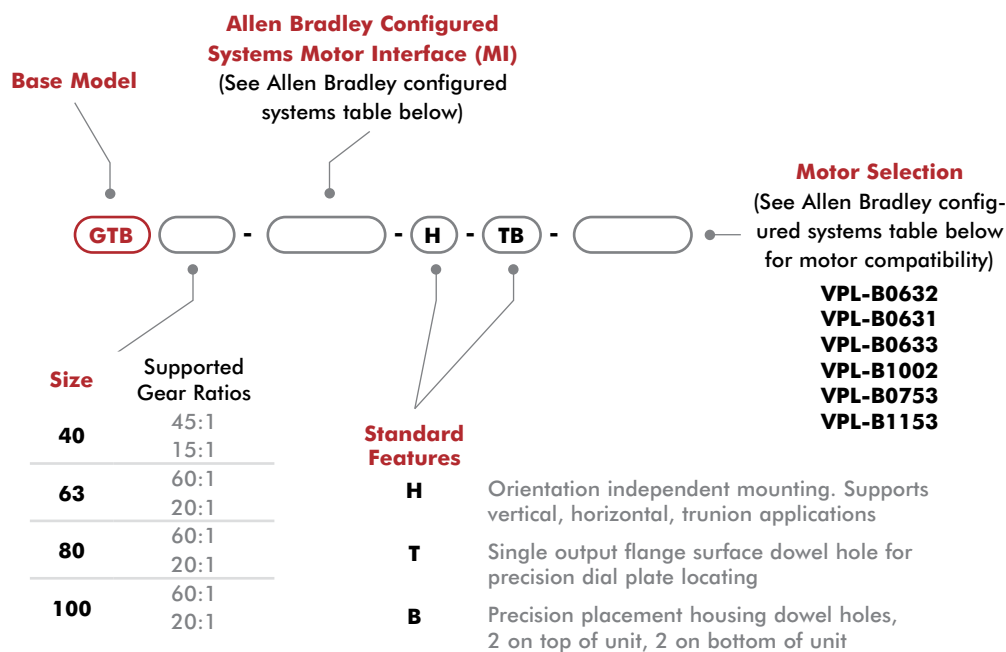

Allen Bradley Configured Systems

Size	Base Part #	Allen Bradley MI Code #	Motor Coupling	Gear Ratio	Motor Vendor	Allen Bradley Motor Part #	Motor Frame mm [in]	Flange size mm [in]	Shaft Ø mm [in]
40	GTB40	FDG20	Direct	15:1	Allen Bradley	VPL-B0632	60 [2.36]	63 [2.48]	9 [0.35]
	GTB40	FGC20	Geared	45:1		VPL-B0631			
63	GTB63	GDP20	Direct	20:1		VPL-B0633			
	GTB63	GGC22	Geared	60:1		VPL-B0632			
80	GTB80	HDP20	Direct	20:1		VPL-B1002	100 [3.94]	100 [3.94]	16 [0.63]
	GTB80	HGD24	Geared	60:1		VPL-B0753	80 [3.15]	75 [2.95]	11 [0.43]
100	GTB100	JDG20	Direct	20:1		VPL-B1153	100 [3.94]	115 [4.53]	19 [0.75]
	GTB100	JGE27	Geared	60:1					

* = Servo Positioner units are assembled, tested and shipped with the above recommended motor for best performance.

GTB SERIES

Globoidal (Roller Gear) Servo Positioner | Specifications

High Torque Gear Drive: High Inertia Application

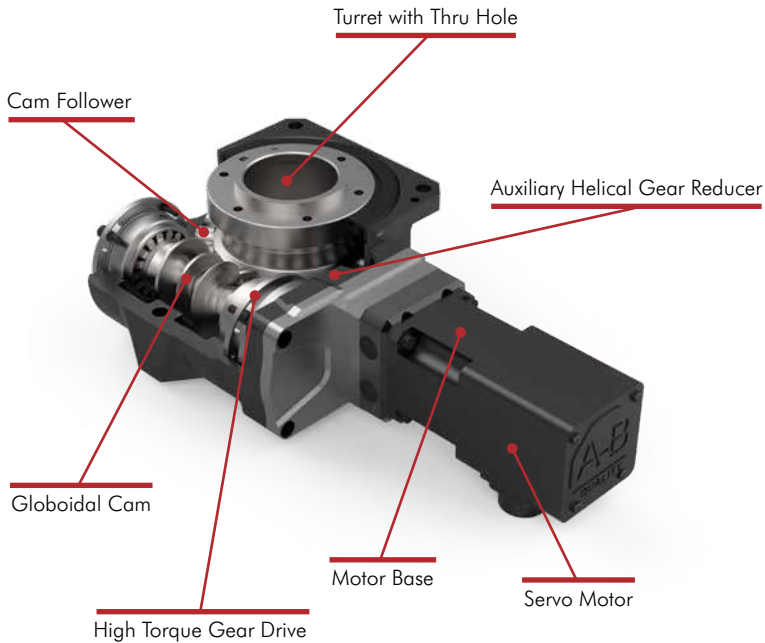

Direct Drive: Zero Backlash Precision Applications

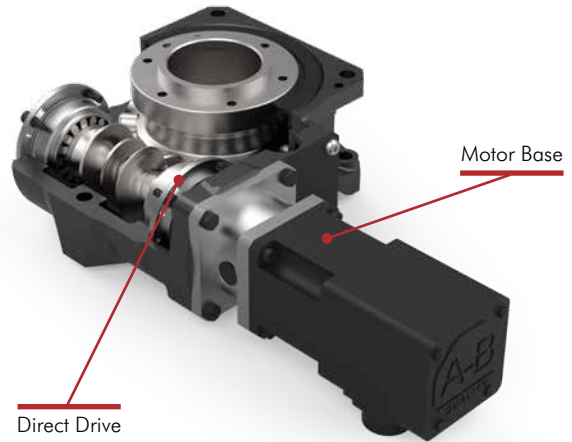

NOTE:

Motor brake must be applied for applications with gravity torque acting on output table (trunnion mounting) in the case of power loss. Follow the instruction manual for fitting and installing motor. Improper handling can cause damage or product malfunction.

General Specifications	Symbol	Units	GTB40		GTB63		GTB80		GTB100	
			Direct	Geared	Direct	Geared	Direct	Geared	Direct	Geared
Motor Coupling			Direct	Geared	Direct	Geared	Direct	Geared	Direct	Geared
Constant lead ratio			15:1	45:1	20:1	60:1	20:1	60:1	20:1	60:1
Center distance		mm [in]	40 [1.57]		63 [2.48]		80 [3.15]		100 [3.94]	
Through hole diameter	Ø	mm [in]	25 [0.98]		50 [1.97]		75 [2.95]		85 [3.35]	
Accuracy		arc-sec	90 ±45		60 ±30		40 ±20		40 ±20	
Repeatability		arc-sec	20 ±10		14 ±7		10 ±5		10 ±5	
Allowable static torque	T _s	N-m [in-lb]	176 [1558]		411 [3637]		600 [5310]		1341 [11868]	
Max start / stop torque	T _U	N-m [in-lb]	94 [832]		210 [1859]		307 [2717]		880 [7789]	
Allow. mean output speed	N _m	rpm	86		55		50		45	
Allow. ultimate output speed	N _U	rpm	100		70		60		50	
Allow. axial cap. on output	P _a	N [lbs]	1100 [247]		1850 [416]		3632 [816]		4100 [922]	
Allow. radial cap. on output	P _r	N [lbs]	740 [166]		1500 [337]		3100 [697]		3420 [769]	
Allow. moment cap. on output	P _{moment}	N-m [in-lb]	40 [354]		85 [752]		226 [2000]		313 [2770]	
Inertia moment on input axis	J	[lb-ft ²] x 10 ⁻⁴ [kg-m ²] x 10 ⁻⁴	[6.24] 0.263	[4.03] 0.17	[20.67] 0.871	[9.49] 0.4	[76.27] 3.214	[36.07] 1.52	[246.55] 10.39	[96.82] 4.08
Backlash		arc-sec	0	25	0	15	0	15	0	10
Average efficiency		%	90	80	90	80	90	80	90	80
Lubrication (Maint. Free)			Grease		Grease		Grease		Grease	
Weight		[lbm] kg	[7.28] 3.3	[7.72] 3.5	[13.01] 5.9	[13.67] 6.2	[28.44] 12.9	[31.09] 14.1	[53.58] 24.3	[55.57] 25.2

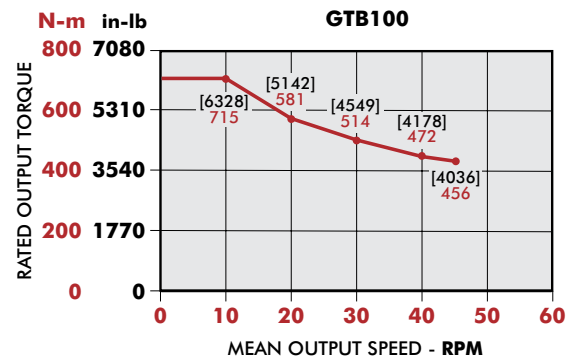
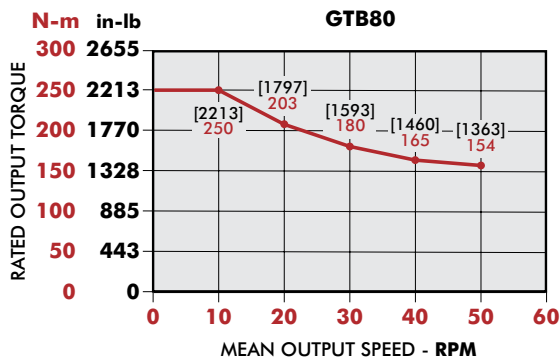
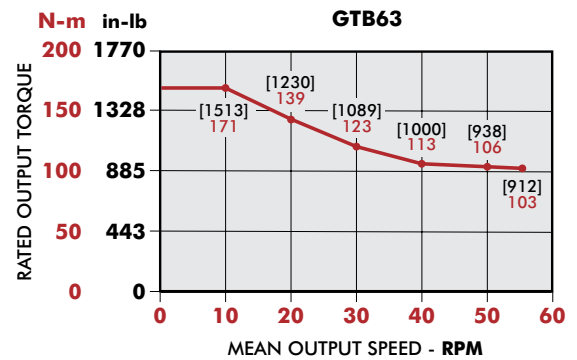
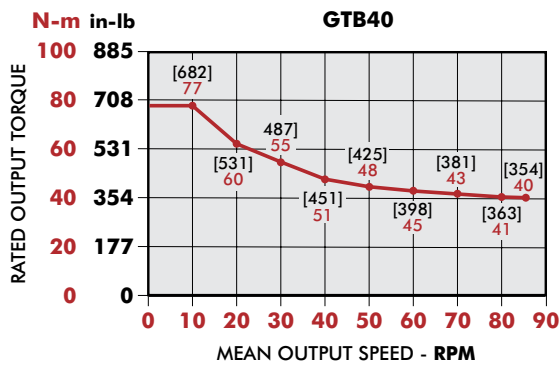

Sizing GTB Series for an Application (Contact Destaco for sizing application support)

1. Load diagram

Check motion profile and resultant inertia torque.
(Add working torque if applied).

Start and stop speed can be simplified to average speed within a segment.

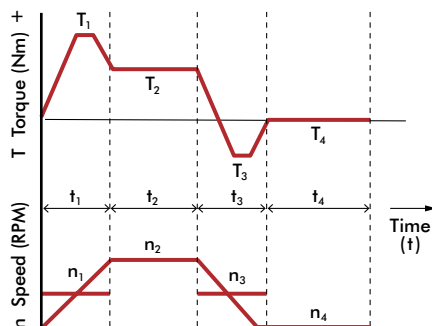

2. Check key conditions

$$\text{Mean torque } T_{mean} = \frac{10}{3} \sqrt{\frac{n_1 \cdot t_1 \cdot |T_1|^{\frac{10}{3}} + n_2 \cdot t_2 \cdot |T_2|^{\frac{10}{3}} + \dots + n_n \cdot t_n \cdot |T_n|^{\frac{10}{3}}}{n_1 \cdot t_1 + n_2 \cdot t_2 + \dots + n_n \cdot t_n}} \quad (\text{N-m})$$

$$\text{Mean output speed } n_{mean} = \frac{n_1 \cdot t_1 + n_2 \cdot t_2 + \dots + n_n \cdot t_n}{t_1 + t_2 + \dots + t_n} \quad (\text{rpm})$$

$$\text{Max output speed } n_{max} \quad (\text{rpm})$$

3. Pre-selection

Choose a size that meets these criteria.

$$T_{mean} < \text{Maximum rated output torque (N-m)}$$

$$n_{mean} < \text{Allowable mean output speed Nm (rpm)}$$

$$n_{max} < \text{Allowable ultimate output speed Nu (rpm)}$$

4. Check specifications

Start/stop torque $T_1 < \text{Maximum rated output torque (N-m)}$
 $T_3 < \text{Maximum rated output torque (N-m)}$

Operation condition factor Smooth without any impact or sudden load $f = 1.0$
 Normal, but occasional emergency stop $f = 1.5$
 Operation with frequent impact or sudden load $f = 3.0$

$$\text{Estimated lifetime } L_h = 12000 \left(\frac{T_{op}}{f \cdot T_{mean}} \right)^{\frac{10}{3}} \quad (\text{hours})$$

5. Selection complete

If above values don't satisfy requirements, go back to step 2 and 3 to re-select size.

GTB40 SERIES

Globoidal (Roller Gear) Servo Positioner | Dimensions

GTB40-FG (Motor Frame Size □ = 38 [1.50], 40 [1.57])

Gear Drive: High Inertia Applications: Ratio 45:1

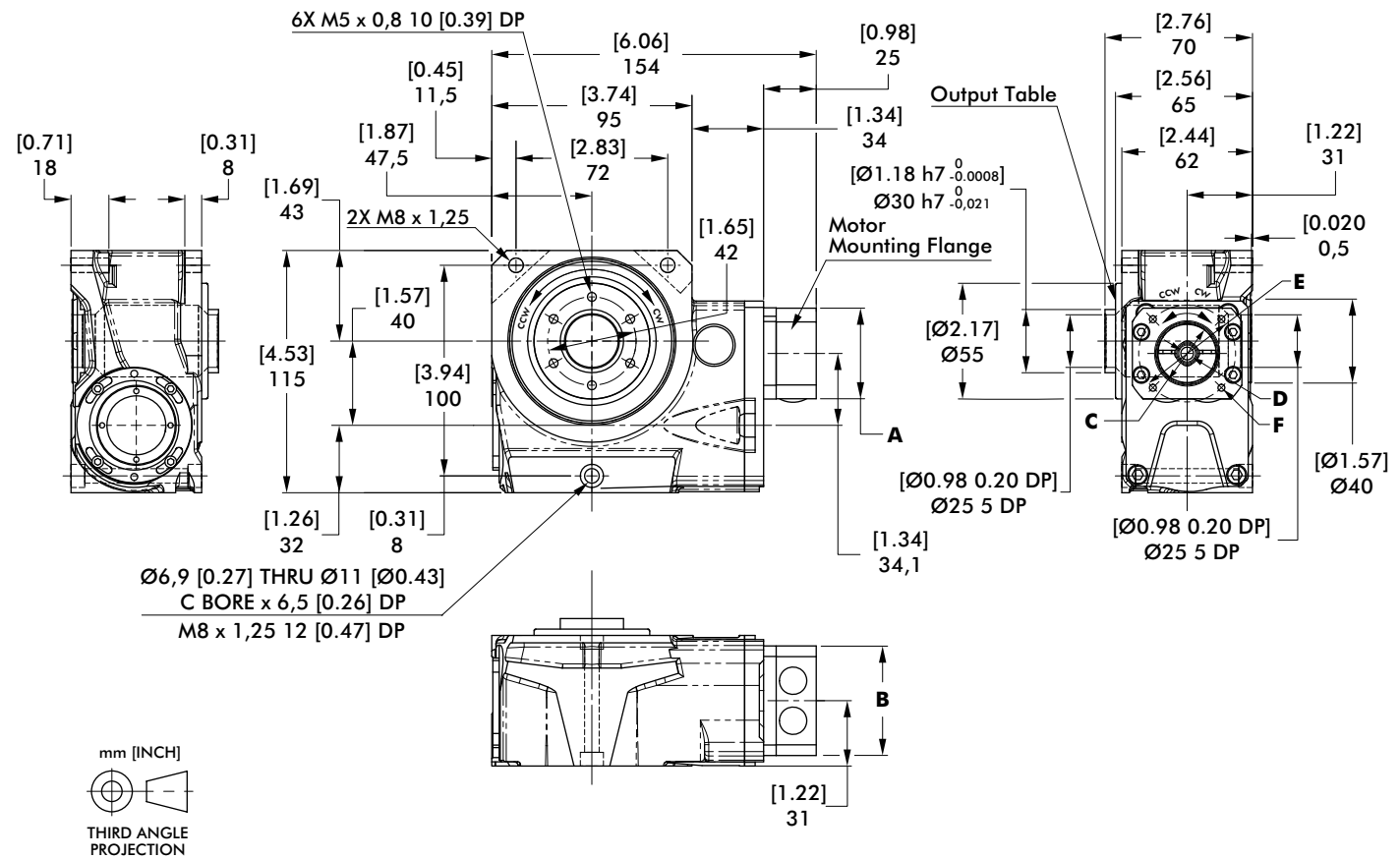

Input/Output Rotation: CW/CCW

MI CODE	A Width mm [in]	B Height mm [in]	C Pilot Ø x Depth mm [in]	D Shaft Ø mm [in]	E Fixing Holes PCD mm [in]	F Fixing Holes Qty x Size mm [in]
FGA20	43 [1.69]	52 [2.05]	Ø30 [1.18] x 4 [0.16]	8 [0.31]	46 [1.81]	4X M4 x 11,5 [0.45] DEEP
FGB20					45 [1.77]	4X M3 x 8,5 [0.33] DEEP
FGC20	55 [2.17]	55 [2.17]	Ø40 [1.57] x 3 [0.12]	9 [0.35]	63 [2.48]	4X M5 X 14 [0.55] DEEP
FGD20						4X M4 X 11,5 [0.45] DEEP

GTB40 SERIES

Globoidal (Roller Gear) Servo Positioner | Dimensions

GTB40-FD (Motor Frame Size □ = 60 [2.37])

Direct Drive: Zero Backlash Precision Applications: Ratio 15:1

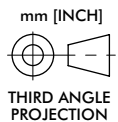
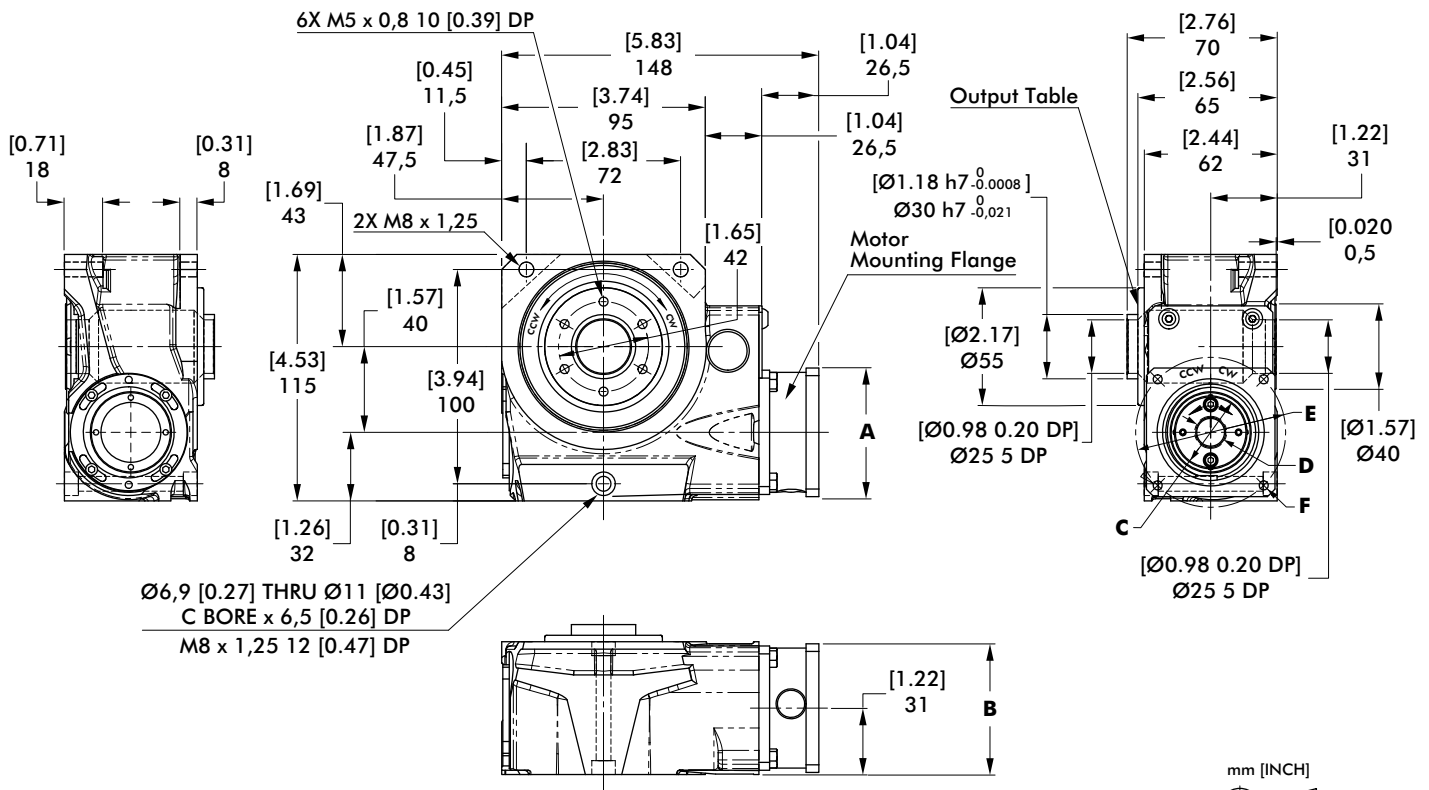

Input/Output Rotation: CW/CCW

MI CODE	A Width mm [in]	B Height mm [in]	C Pilot Ø x Depth mm [in]	D Shaft Ø mm [in]	E Fixing Holes PCD mm [in]	F Fixing Holes Qty x Size mm [in]
FDA20	60 [2.36]	60 [2.36]	Ø50 [1.97] x 4 [0.16]	Ø14 [0.55]	Ø70 [2.76]	4X M5 THRU
FDB20				Ø11 [0.43]		
FDC20				Ø14 [0.55]		
FDD20				Ø9 [0.35]		
FDE20				Ø12 [0.47]		
FDF20	55 [2.17]	55 [2.17]	Ø40 [1.57] x 4 [0.16]	Ø9 [0.35]	Ø63 [2.48]	4X M5 THRU
FDG20				Ø9 [0.35]		
FDH20				Ø11 [0.43]		
FDJ20				Ø9 [0.35]		
FDK20	90 [3.54]	90 [3.54]	Ø80 [3.15] X 4 [0.16]	Ø16 [0.63]	Ø100 [3.94]	4X M6 THRU

GTB63 SERIES

Globoidal (Roller Gear) Servo Positioner | Dimensions

GTB-63-GG (Motor Frame Size □ = 60 [2.37])

Gear Drive: High Inertia applications: Ratio 60:1

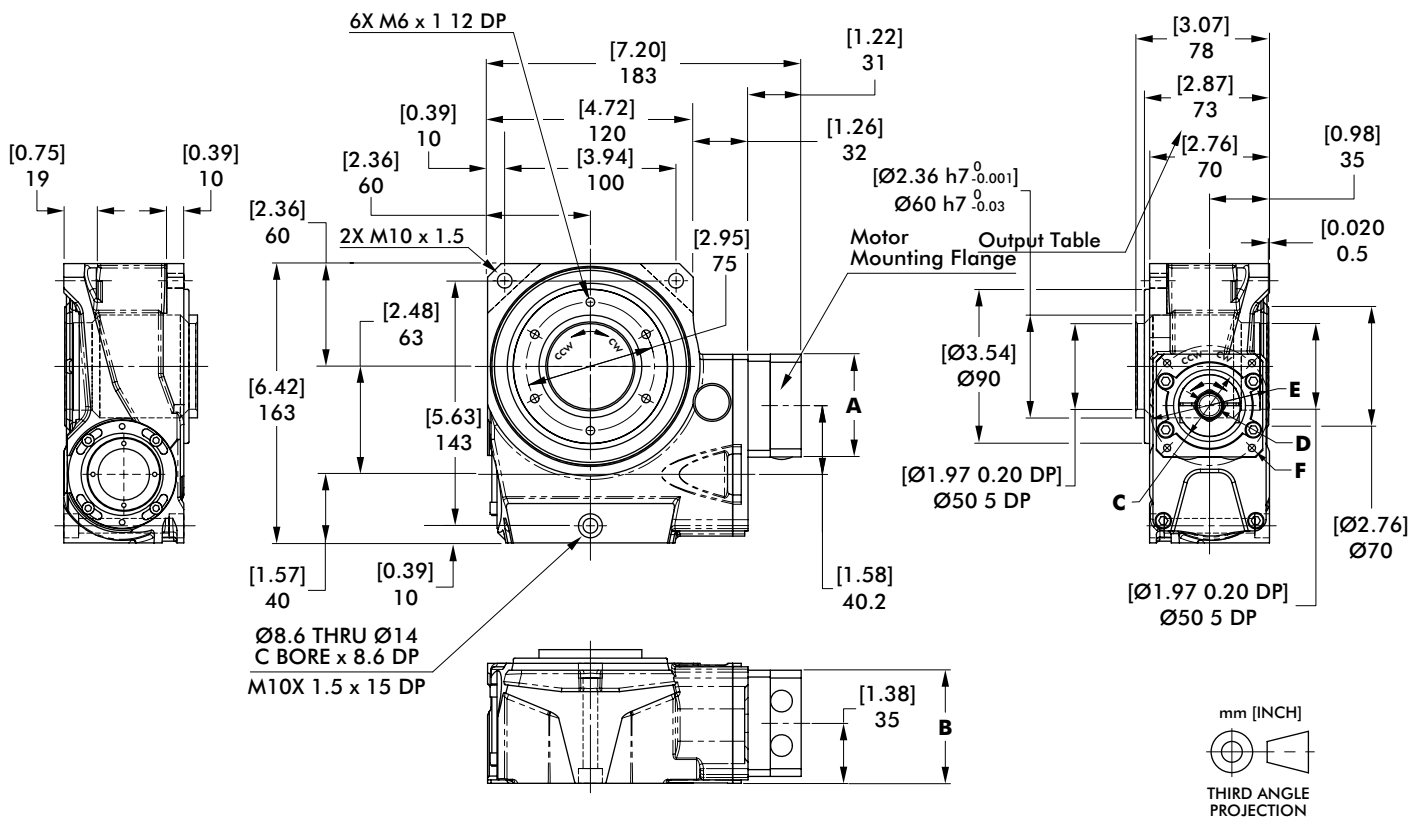

Input/Output Rotation: CW/CCW

MI CODE	A Width mm [in]	B Height mm [in]	C Pilot Ø x Depth mm [in]	D Shaft Ø mm [in]	E Fixing Holes PCD mm [in]	F Fixing Holes Qty x Size mm [in]
GGA20	60 [2.36]	62 [2.44]	Ø50 [1.97] x 5 [0.20]	Ø14 [0.55]	Ø70 [2.76]	4X M5 x 14 [0.55] Deep
GGA22				Ø9 [0.35]		
GGB20				Ø14 [0.55]		
GGB21				Ø11 [0.43]		
GGC22	70 [2.76]	70 [2.76]	Ø40 [1.57] x 3 [0.12]	Ø9 [0.35]	Ø63 [2.48]	4X M5 x 14 [0.55] Deep
GGD23				Ø12 [0.47]	Ø70 [2.76]	
GGE24				Ø11 [0.43]	Ø75 [2.95]	
GGF22	60 [2.36]	62 [2.44]	Ø40 [1.57] x 3 [0.12]	Ø9 [0.35]	Ø63 [2.48]	4X M4 x 11,5 [0.45] Deep
GGG20	70 [2.76]	70 [2.76]	Ø60 [2.36] x 5 [0.20]	Ø14 [0.55]	Ø75 [2.95]	4X M6 x 16 [0.63] Deep

GTB63 SERIES

Globoidal (Roller Gear) Servo Positioner | Dimensions

GTB63-GD (Motor Frame Size □ = 60 [2.36], 80 [3.15], 86 [3.39], 90 [3.54])

Direct Drive: Ratio 20:1

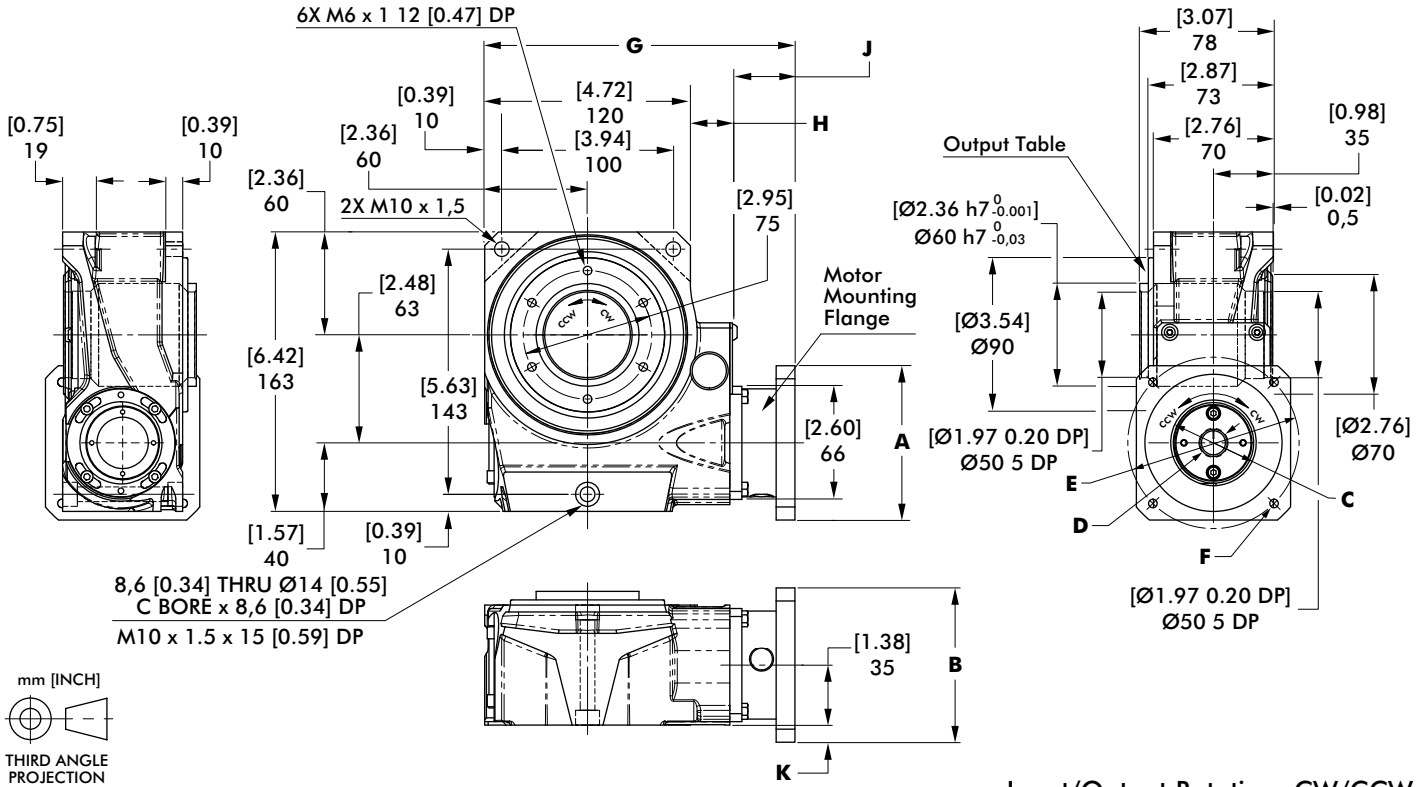

mm [INCH]
THIRD ANGLE PROJECTION

MI CODE	A Width mm [in]	B Height mm [in]	C Pilot Ø x Depth mm [in]	D Shaft Ø mm [in]	E Fixing Holes PCD mm [in]	F Fixing Holes Qty x Size mm [in]
GDA20	60 [2.36]	60 [2.36]	Ø50 [1.97] x 4 [0.16]	Ø14 [0.55]	Ø70 [2.76]	4X M5 THRU
GDB20	80 [3.15]	80 [3.15]	Ø70 [2.76] x 4 [0.16]	Ø19 [0.75]	Ø90 [3.54]	
GDC20				Ø14 [0.55]		4X M6 THRU
GDD20	90 [3.54]	90 [3.54]	Ø80 [3.15] x 6 [0.24]	Ø16 [0.63]	Ø100 [3.94]	
GDE20						4X M6 THRU
GDF20	60 [2.36]	60 [2.36]	Ø50 [1.97] x 4 [0.16]	Ø14 [0.55]	Ø70 [2.76]	4X M4 THRU
GDG20				Ø19 [0.75]		4X M5 THRU
GDH20	80 [3.15]	80 [3.15]	Ø70 [2.76] x 4 [0.16]	Ø14 [0.55]	Ø90 [3.54]	
GDJ20				Ø16 [0.63]		4X M6 THRU
GDK20	90 [3.54]	90 [3.54]	Ø80 [3.15] x 6 [0.24]	Ø10 [0.39]	Ø100 [3.94]	
GDL20	60 [2.36]	60 [2.36]	Ø50 [1.97] x 4 [0.16]	Ø12 [0.47]	Ø70 [2.76]	4X M5 THRU
GDM20	80 [3.15]	80 [3.15]	Ø70 [2.76] x 4 [0.16]	Ø16 [0.63]	Ø90 [3.54]	4X M6 THRU
GDN20	72 [2.83]	72 [2.83]	Ø60 [2.36] x 4 [0.16]	Ø14 [0.55]	Ø75 [2.95]	
GDP20	55 [2.17]	55 [2.17]	Ø40 [1.57] x 5 [0.20]	Ø9 [0.35]	Ø63 [2.48]	
GDQ20						4X M5 THRU
GDR20	70 [2.76]	70 [2.76]	Ø60 [2.36] x 4 [0.16]	Ø11 [0.43]	Ø75 [2.95]	



Frame Size	G	H	J	K
60	178 [7.01]	24,5 [0.96]	33,5 [1.32]	--
80	180 [7.09]		35,5 [1.40]	5 [0.20]
86	181 [7.13]		36,5 [1.44]	10 [0.39]
90				

GTB63 SERIES

Globoidal (Roller Gear) Servo Positioner | Dimensions

GTB63 Option Specifications

Dowel Hole Option -B, Housing -T: Output Table

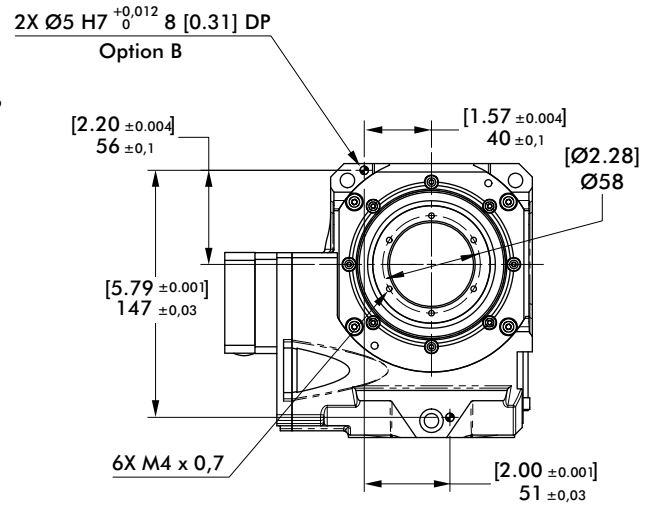
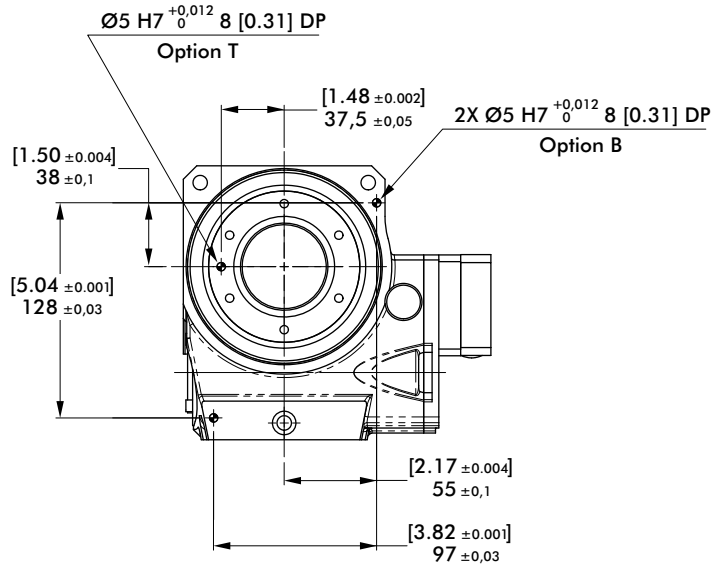

GTB80 SERIES

Globoidal (Roller Gear) Servo Positioner | Dimensions

GTB80-HG (Motor Frame Size □ = 80 [3.15], 86 [3.39], 90 [3.54])

Gear Drive: High Inertia Applications: Ratio 60:1

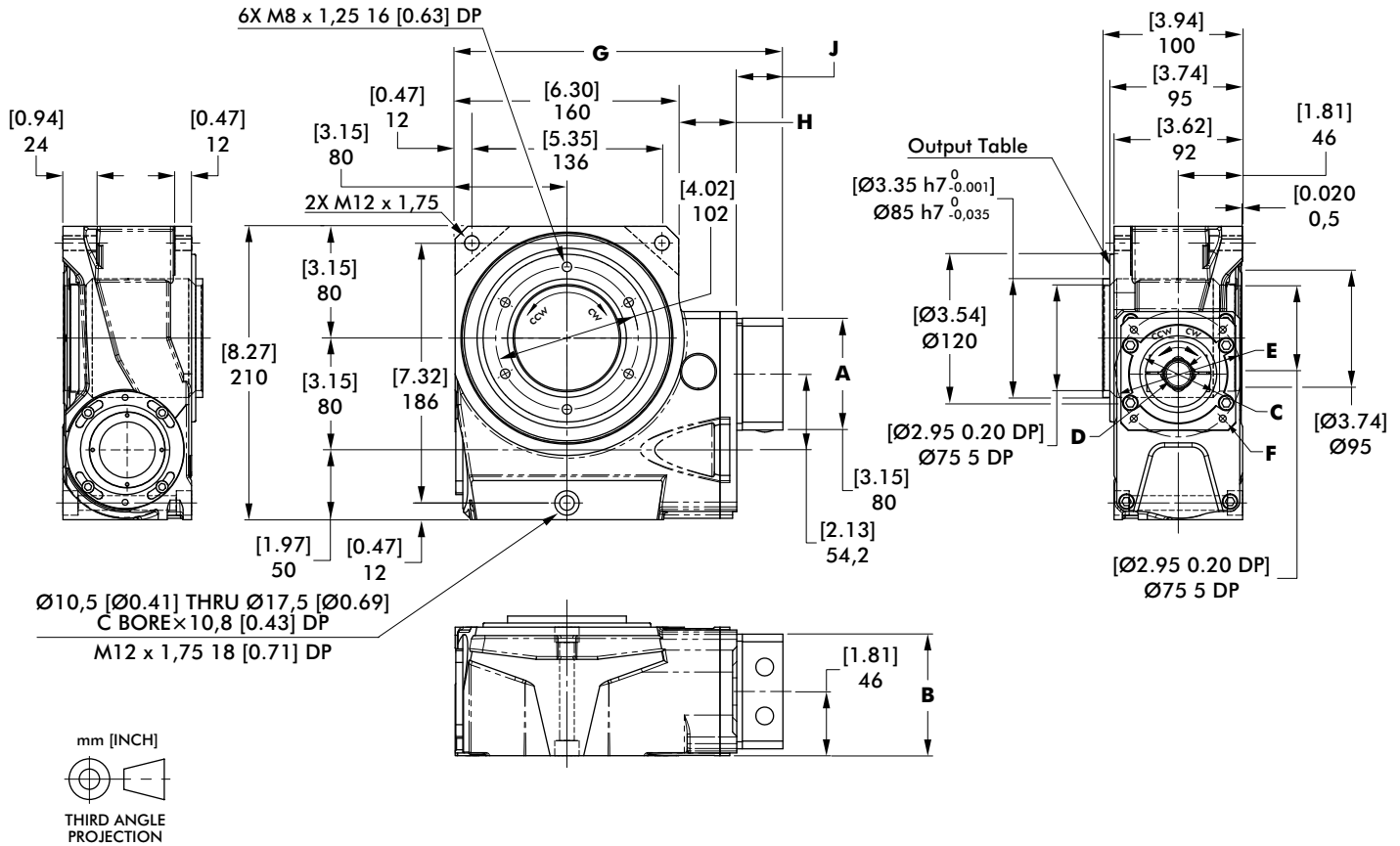

Input/Output Rotation: CW/CCW

MI CODE	A Width mm [in]	B Height mm [in]	C Pilot Ø x Depth mm [in]	D Shaft Ø mm [in]	E Fixing Holes PCD mm [in]	F Fixing Holes Qty x Size mm [in]
HGA20	80 [3.15]	82 [3.23]	Ø70 [2.76] x 4,5 [0.18]	Ø19 [0.75]	Ø90 [3.54]	4X M6 THRU
HGA22						4X M6 x 17 [0.67] DEEP
HGB21	90 [3.54]	88 [3.46]	Ø80 [3.15] x 7 [0.28]	Ø16 [0.63]	Ø100 [3.94]	4X M6 THRU
HGB22						4X M6 x 17 [0.67] DEEP
HGB23	80 [3.15]	82 [3.23]	Ø70 [2.76] x 4,5 [0.18]	Ø19 [0.75]	Ø90 [3.54]	4X M5 x 14 [0.55] DEEP
HGC20			Ø60 [2.36] x 3 [0.12]	Ø11 [0.43]	Ø75 [2.95]	
HGD24	80 [3.15]	82 [3.23]	Ø70 [2.76] x 4,5 [0.18]	Ø16 [0.63]	Ø90 [3.54]	4X M6 THRU
HGE22			Ø60 [2.36] x 4 [0.16]	Ø14 [0.55]	Ø75 [2.95]	
HGF25	90 [3.54]	88 [3.46]	Ø80 [3.15] x 4 [0.16]	Ø16 [0.63]	Ø100 [3.94]	4X M6 x 15 [0.59] DEEP
HGG26			Ø80 [3.15] x 4 [0.16]	Ø14 [0.55]	Ø100 [3.94]	
HGG25	90 [3.54]	88 [3.46]	Ø80 [3.15] x 4 [0.16]	Ø16 [0.63]	Ø100 [3.94]	4X M6 x 15 [0.59] DEEP
HGH20	98 [3.86]	98 [3.86]	Ø95 [3.74] x 4 [0.16]	Ø19 [0.75]	Ø115 [4.53]	4X M8 x 22,5 [0.89] DEEP



80



86/90

Frame Size	G	H	J
80	234 [9.21]	41,5 [1.63]	33 [1.30]
86	241 [9.49]	45,5 [1.79]	35,5 [1.40]
90			

GTB80 SERIES

Globoidal (Roller Gear) Servo Positioner | Dimensions

GTB80-HD (Motor Frame Size □ = 80 [3.15], 86 [3.39], 90 [3.54], 100 [3.94])

Direct Drive: Zero Backlash Precision Applications: Ratio 20:1

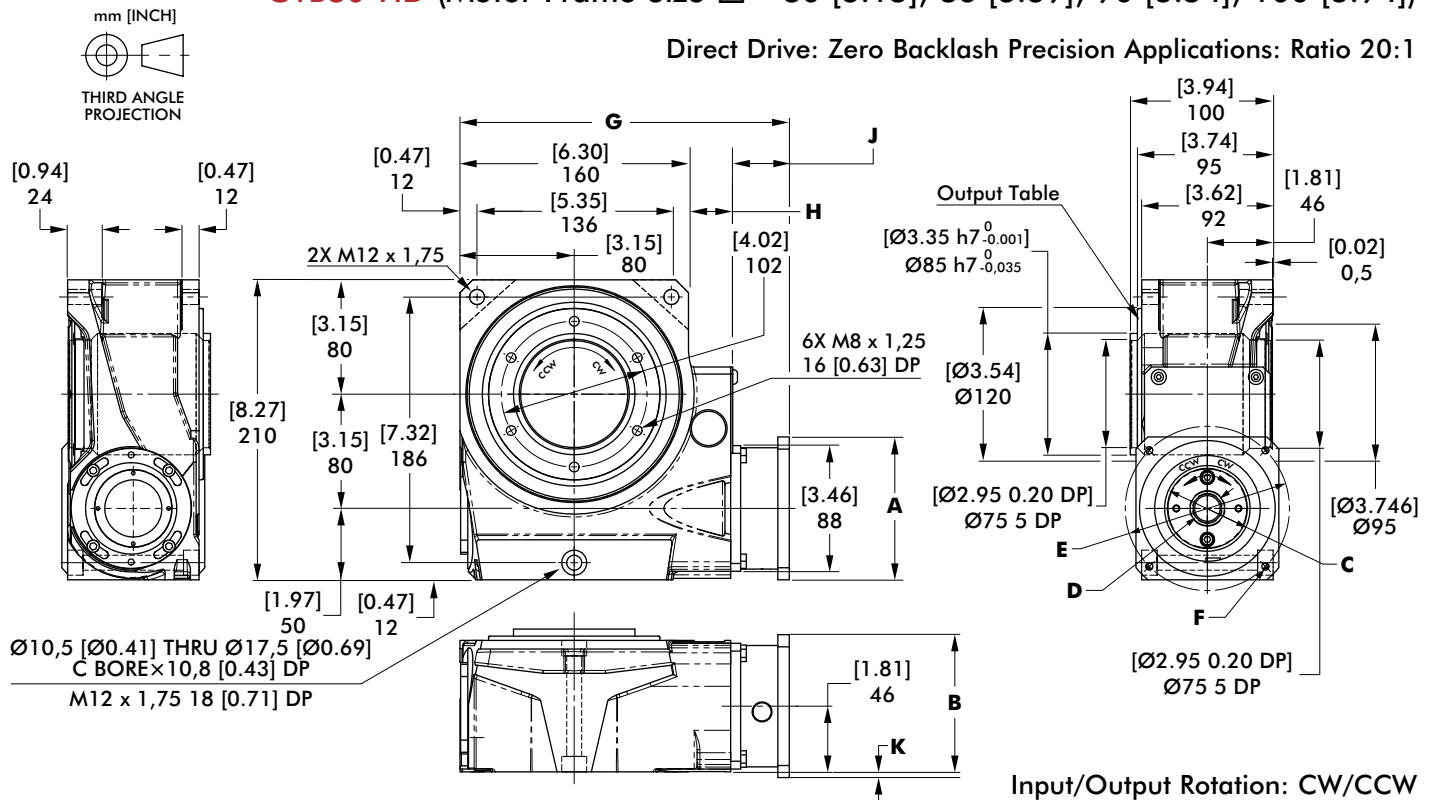

MI CODE	A Width mm [in]	B Height mm [in]	C Pilot Ø x Depth mm [in]	D Shaft Ø mm [in]	E Fixing Holes PCD mm [in]	F Fixing Holes Qty x Size mm [in]
HDA20	80 [3.15]	80 [3.15]	Ø70 [2.76] x 4,5 [0.18]	Ø19 [0.75]	Ø90 [3.54]	
HDB20	90 [3.54]	90 [3.54]	Ø80 [3.15] x 5,5 [0.22]	Ø14 [0.55]	Ø100 [3.94]	4X M6 THRU
HDC20				Ø16 [0.63]		
HDD20	100 [3.94]	100 [3.94]	Ø95 [3.74] x 3,5 [0.14]	Ø24 [0.94]	Ø115 [4.53]	
HDE20	80 [3.15]	80 [3.15]	Ø70 [2.76] x 4,5 [0.18]	Ø19 [0.75]	Ø90 [3.54]	4X M5 THRU
HDF20	100 [3.94]	100 [3.94]	Ø95 [3.74] x 3,5 [0.14]		Ø115 [4.53]	4X M8 THRU
HDG20				Ø95 [3.74] x 7,5 [0.30]		
HDH20	80 [3.15]	80 [3.15]	Ø70 [2.76] x 4,5 [0.18]	Ø16 [0.63]	Ø90 [3.54]	4X M6 THRU
HDJ20	90 [3.54]	90 [3.54]	Ø80 [3.15] x 5,5 [0.22]		Ø100 [3.94]	
HDK20	100 [3.94]	100 [3.94]	Ø95 [3.74] x 3,5 [0.14]	Ø22 [0.87]	Ø115 [4.53]	4X M8 THRU
HDL20	90 [3.54]	90 [3.54]	Ø80 [3.15] x 5,5 [0.22]	Ø10 [0.39]	Ø100 [3.94]	4X M6 THRU
HDM20	100 [3.94]	100 [3.94]	Ø95 [3.74] x 7,5 [0.30]	Ø22 [0.87]	Ø115 [4.53]	4X M8 THRU
HDN20	96 [3.78]	96 [3.78]	Ø80 [3.15] x 4 [0.16]	Ø19 [0.75]	Ø100 [3.94]	4X M6 THRU
HDP20	90 [3.54]	90 [3.54]	Ø80 [3.15] x 3,5 [0.14]	Ø16 [0.63]	Ø100 [3.94]	4X M3 THRU
HDQ20	100 [3.94]	100 [3.94]	Ø95 [3.74] x 3,5 [0.14]	Ø19 [0.75]	Ø115 [4.53]	4X M8 THRU
HDR20	90 [3.54]	90 [3.54]	Ø80 [3.15] x 3,5 [0.14]	Ø14 [0.55]	Ø100 [3.94]	4X M6 THRU
HDS20						
HDT20	114 [4.49]	114 [4.49]	Ø110 [4.33] x 4 [0.16]	Ø24 [0.94]	Ø130 [5.12]	4X M8 THRU



Frame Size	G	H	J	K
80	226,5 [8.92]	31 [1.22]	35,5 [1.40]	--
86				
90	230,5 [9.07]		39,5 [1.56]	
100				4 [0.16]

GTB80 SERIES

Globoidal (Roller Gear) Servo Positioner | Dimensions

GTB80 Option Specifications

Dowel Hole Option -B, Housing -T: Output Table

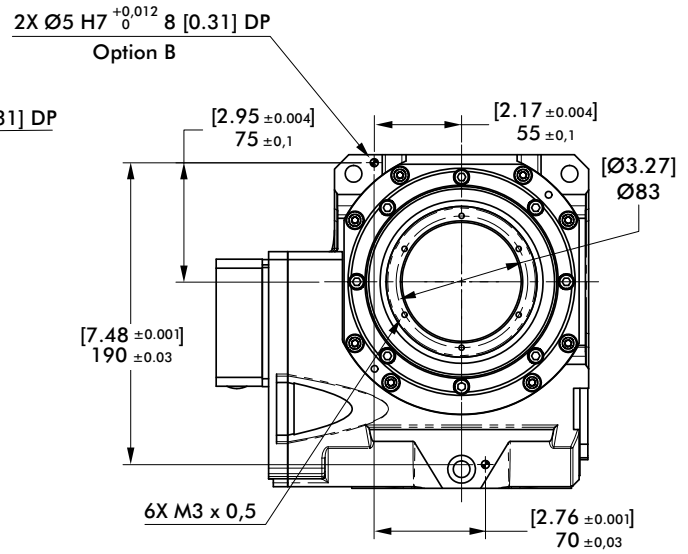
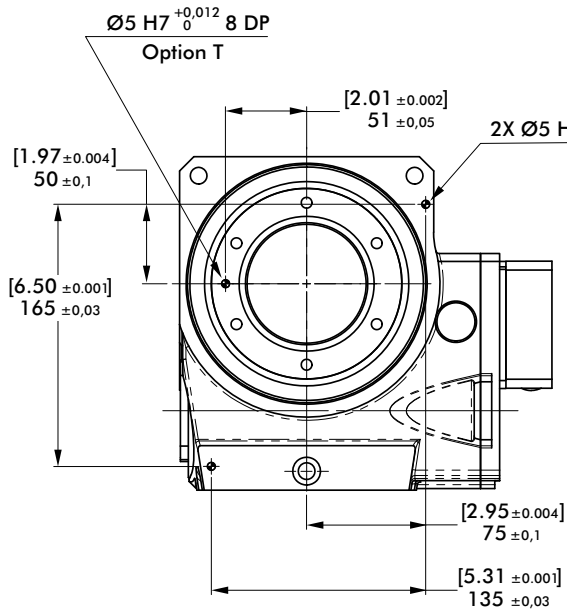

GTB100 SERIES

Globoidal (Roller Gear) Servo Positioner | Dimensions

GTB100-JG (Motor Frame Size □ = 90 [3.54], 100 [3.94], 130 [5.12])

Gear Drive: High Inertia applications: Ratio 60:1

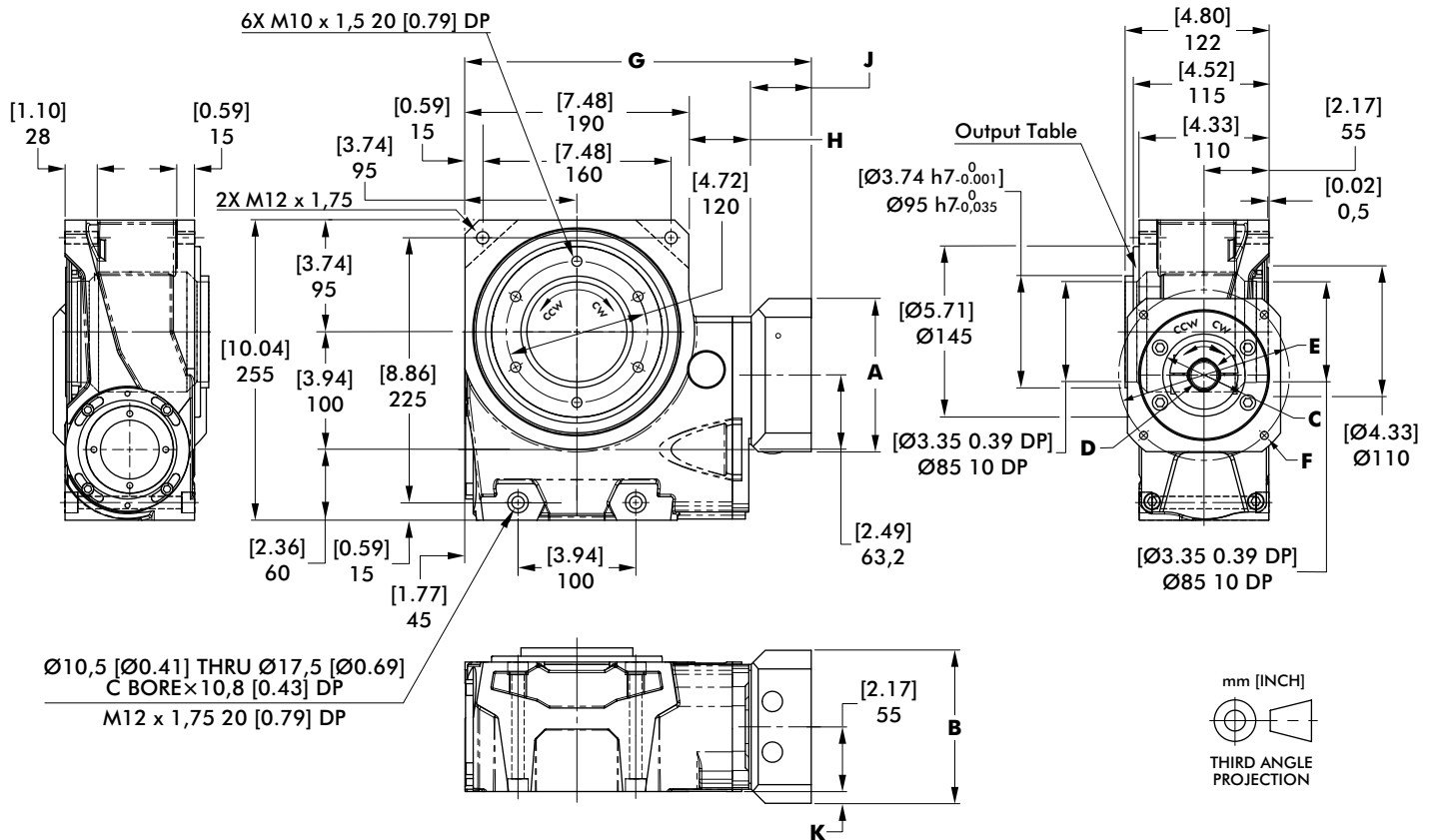

Input/Output Rotation: CW/CCW

MI CODE	A Width mm [in]	B Height mm [in]	C Pilot Ø x Depth mm [in]	D Shaft Ø mm [in]	E Fixing Holes PCD mm [in]	F Fixing Holes Qty x Size mm [in]
JGA20				Ø24 [0.94]		
JGA21	130 [5.12]	130 [5.12]	Ø110 [4.33] x 7 [0.28]	Ø19 [0.75]	Ø145 [5.71]	4X M8 x 22,5 [0.89] Deep
JGA22				Ø22 [0.87]		
JGB23				Ø14 [0.55]		
JGB24	90 [3.54]	90 [3.54]	Ø80 [3.15] x 9,5 [0.37]	Ø16 [0.63]	Ø100 [3.94]	
JGB25				Ø10 [0.39]		4X M6 x 17 [0.67] Deep
JGC20	100 [3.94]	100 [3.94]	Ø95 [3.74] x 5,5 [0.22]	Ø24 [0.94]	Ø115 [4.53]	
JGD26	90 [3.54]	90 [3.54]	Ø80 [3.15] x 9,5 [0.37]	Ø16 [0.63]	Ø100 [3.94]	
JGE22				Ø22 [0.87]		
JGE27	100 [3.94]	100 [3.94]	Ø95 [3.74] x 7,5 [0.30]	Ø19 [0.75]	Ø115 [4.53]	4X M8 x 22,5 [0.89] Deep
JGF27	96 [3.78]	96 [3.78]	Ø80 [3.15] x 5 [0.20]	Ø19 [0.75]	Ø100 [3.94]	4X M6 x 17 [0.67] Deep
JGG20	114 [4.49]	114 [4.49]	Ø110 [4.33] x 3,5 [0.14]	Ø24 [0.94]	Ø130 [5.12]	4X M8 x 22,5 [0.89] Deep



Frame Size	G	H	J	K
90	280 [11.02]	51 [2.01]	39 [1.54]	--
100	281 [11.06]	53 [2.09]	38 [1.50]	
130	280 [11.02]		51 [2.01]	10 [0.39]

GTB100 SERIES

Globoidal (Roller Gear) Servo Positioner | Dimensions

GTB100-JD (Motor Frame Size □ = 100 [3.94], 130 [5.12])

Direct Drive: Zero Backlash Precision Applications: Ratio 20:1

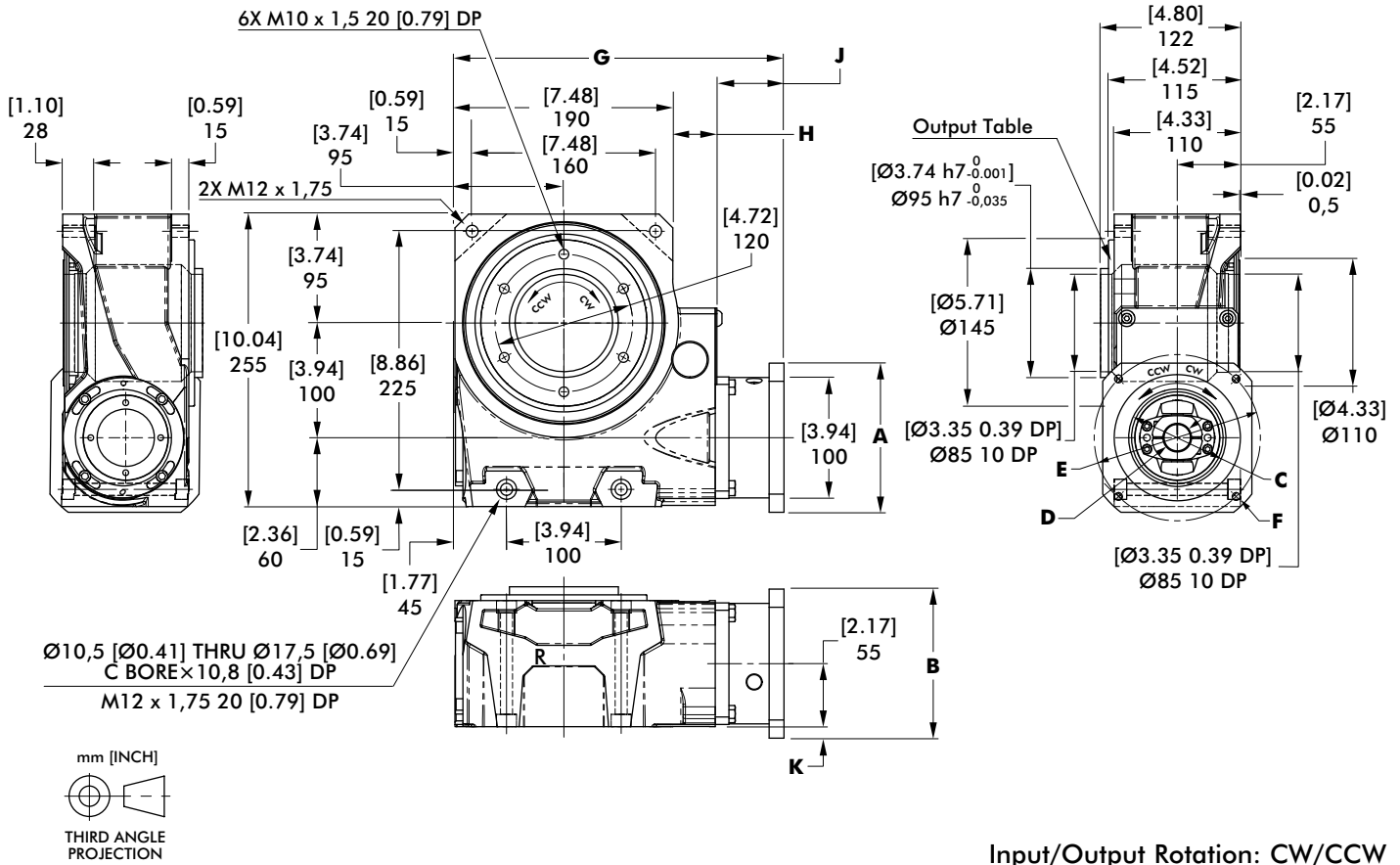

Input/Output Rotation: CW/CCW

MI CODE	A Width mm [in]	B Height mm [in]	C Pilot Ø x Depth mm [in]	D Shaft Ø mm [in]	E Fixing Holes PCD mm [in]	F Fixing Holes Qty x Size mm [in]
JDA20	130 [5.12]	130 [5.12]	Ø110 [4.33] x 6,5 [0.26]	Ø19 [0.75]	Ø145 [5.71]	4X M8 THRU
JDB20	130 [5.12]	130 [5.12]	Ø110 [4.33] x 6,5 [0.26]	Ø22 [0.87]	Ø145 [5.71]	
JDC20	100 [3.94]	100 [3.94]	Ø95 [3.74] x 5,5 [0.22]	Ø24 [0.94]	Ø115 [4.53]	4X M6 THRU
JDD20			Ø95 [3.74] x 5,5 [0.22]	Ø22 [0.87]		
JDE20	126 [4.96]	126 [4.96]	Ø110 [4.33] x 4,5 [0.18]	Ø24 [0.94]	Ø130 [5.12]	4X M8 THRU
JDF20	100 [3.94]	100 [3.94]	Ø95 [3.74] x 3,5 [0.14]	Ø19 [0.75]	Ø115 [4.53]	
JDG20	114 [4.49]	114 [4.49]	Ø110 [4.33] x 3,5 [0.14]	Ø24 [0.94]	Ø130 [5.12]	
JDH20	100 [3.94]	100 [3.94]	Ø95 [3.74] x 3,5 [0.14]	Ø19 [0.75]	Ø115 [4.53]	
JDJ20	114 [4.49]	114 [4.49]	Ø110 [4.33] x 3,5 [0.14]	Ø24 [0.94]	Ø130 [5.12]	
JDK20	100 [3.94]	100 [3.94]	Ø95 [3.74] x 3,5 [0.14]	Ø19 [0.75]	Ø115 [4.53]	
JDL20	126 [4.96]	126 [4.96]	Ø110 [4.33] x 4,5 [0.18]	Ø19 [0.75]	Ø130 [5.12]	



90



130

Frame Size	G	H	J	K
100	284 [11.18]	38,5 [1.52]	55,5 [2.19]	--
130	287 [11.30]	38,5 [1.52]	58,5 [2.30]	10 [0.39]

PRECISION INDEXING SOLUTIONS

Features and Benefits

The **CAMCO RDM Series** is a line of cam-operated rotary index drives, designed to move a wide array of products and components smoothly and with precision. Preloaded for no backlash, they have the capacity for handling high loads and speeds with controlled acceleration and deceleration for repeatable, accurate positioning.

- High precision, hardened cams available in standard and special motions
- Superior accuracy at the working radius when compared to a traditional indexer
- Sealed 4-point contact output bearing and large cam followers for superior accuracy and load capacity
- 60 Station capacity, ideal for multi-part automatic assembly machines
- Center through hole accommodates machine utilities
- Servo-driven solutions available for complex or variable indexing profiles
- Optional Output Overload Clutch available



Application Examples

Cycle on Demand Indexer with Fixed Number of Stations

- RDM indexer with user controlled variable dwell time
- Single index cycle with user controlled variable dwell time
- Index time is controlled by varying frequency setting of inverter drive
- 60 or 30 indexing cycles per minute using an AC or DC motor and drive respectively
- Increased productivity cycle rates with an Output Clutch-Brake option

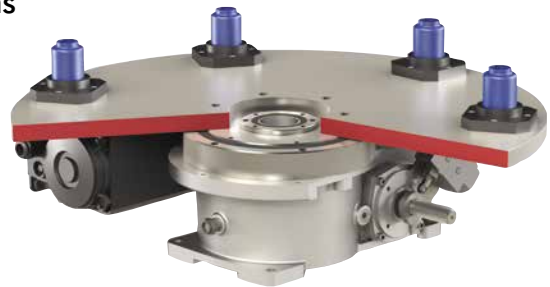

Cambot Flexible Pick and Place Solutions

- Servo driven indexer supporting high moment capacity payloads
- Large output flange for mounting a custom end-effector solution
- Integrate Destaco's versatile grippers, slides and vacuum products for pick and place actuation



CAMCO XPRESS PROGRAM

601RDM and 902RDM Series

Destaco continues to offer excellent service to our customers by providing the most common models of our **Camco RDM Series** as fast as you need them.



Base Models

Please contact your Destaco Camco Sales Team to learn more features of the RDM Series and details of the Xpress Program.



601RDM
Load Capacity:
 Radial: 945 lbs
 Thrust/Axial: 2360 lbs



902RDM
Load Capacity:
 Radial: 3540 lbs
 Thrust/Axial: 7000 lbs
 with Standard Torque and
 Detector Plate Settings



Stops		Motion	Reducer	Ratio	Motor	Optional Controller	Clutch
(M)601RDM	(M)902RDM						
2	2				601RDM W/0.33HP 230/460V or 90/180V DC Motor	Allen Bradley PowerFlex 523 / 525 <small>(Allen Bradley, PowerFlex are registered brands of Rockwell Automation)</small>	(M)4.0D
4	4				902RDM W/1HP, 56C 230/460V or 90/180V DC Motor		(M)7.8D
6	6						
8	8						
12	12						
16							
						Camco Vari-Pak	

RDM SERIES

Rotary Index Drive | How To Order

Base Model*		Option Tables Page #	Index Mounting (See Figure 1)	Reducer/Motor (Table 1) Note: Set Reducer Mounting option to 0 when Reducer/Motor option is 0000.	Reducer Mounting (See Figure 2)		Cycling Sensor (See Figure 3) Description				
Imperial	Metric				0 = No Reducer	0 = No Sensors	A	B	C	D	E
N/A	80RDM	5	1		A	J	A	Single Cam w/PNP Prox			
601RDM	M601RDM	11	2		B	K	B	Single Cam w/NPN Prox			
902RDM	M902RDM	17	3		C	L	C	Dual Cam w/PNP Prox			
N/A	1100RDM	23	4		D	M	D	Dual Cam w/NPN Prox			
1305RDM	M1305RDM	29	5		E	N	E	Single Cam/Prox Bracket			
1800RDM	M1800RDM	35	6		F	P	F	Dual Cam/Prox Bracket			
					G	R	G	Single Cam, w/Mech LS			
					H	S	H	Dual Cam, w/Mech LS			

*Right Hand Cam only



Motion	Description
A	2-Stop-330
B	3-Stop-330
C	4-Stop-270
D	4-Stop-330
E	6-Stop-270
F	6-Stop-330
G	8-Stop-270
H	8-Stop-330
I	12-Stop-270
J	12-Stop-330
K	16-Stop-270
L	16-Stop-330
M	8:1 Constant-Lead
N	12:1 Constant-Lead
P	16:1 Constant-Lead
R*	24:1 Constant-Lead

Center Post	Code	Description
All Sizes	0	No Reducer
	P	Center Post
902 1100 1305	T	Tool Plate Mounting Holes
	B	Center Post + Tool Plate Mounting Holes



*Models 601, 902, 1100 only.

Motor Brake Settings (Table 2)

Reducer Gear Ratio (Table 3)

Output Clutch (Table 4)

Motor Control (Table 5)



Input Shaft Configuration/Rotation

Relative Rotation for Right Hand Cam:

Side 1: CW Input, CCW Output

Side 2: CCW input, CW Output

NOTE: Input can be driven in either direction. Reducer, Motor and adapter plates can be mounted on either side 1 or side 2 to drive input.

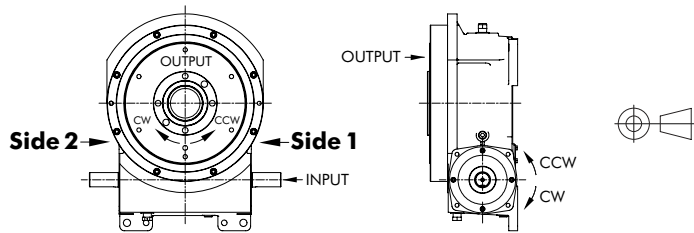

Index Mounting (Figure 1)

OVOI (output vertical, over input)	OVUI (output vertical, under input)	OHOI (output horizontal, over input)	OHUI (output horizontal, under input)	H-S1-UP (output horizontal, side 1 up)	H-S2-UP (output horizontal, side 2 up)
1	2	3	4	5	6

Other Motions (stops and index periods) available. Contact your DESTACO sales representative for more information.

Gear Reducer Mounting Positions (Figure 2)

		Mounting "A"		Mounting "B"	
		Right Hand	Left Hand	Right Hand	Left Hand
SIDE 1					
SIDE 2					

Cycling Sensor Options (Figure 3)

Single Cam with (A) PNP or (B) NPN Proximity Sensor	Dual Cam with (A) PNP or (B) NPN Proximity Sensor	Single Cam with Proximity Sensor Bracket	Dual Cam with Proximity Sensor Bracket	Single Cam with Mechanical Limit Switch	Dual Cam with Mechanical Limit Switch

80RDM SERIES

Rotary Index Drive | How To Order

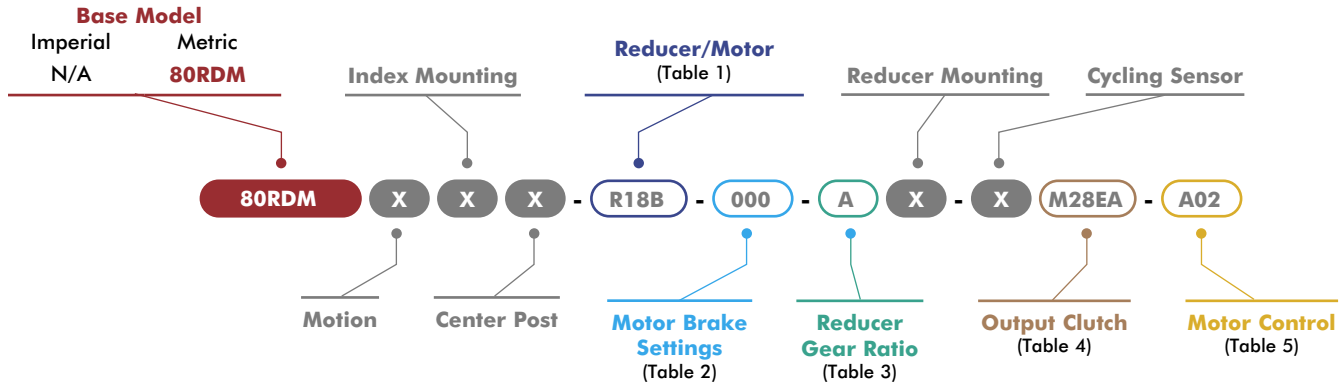

X = See Page 3 for option information.

1 Reducer/Motor Options

Code	Description
0000	No Reducer or Motor*
R180 Motors	
R18X	R180 Adapter only*
R18A	R180 Reducer
R18B	R180 Reducer with 0.33HP 230/460V AC Motor
R18C	R180 Reducer with 0.33HP 90V DC Motor
R18D	R180 Reducer with 0.33HP 180V DC Motor
STM RMI-28/40 Motors	
RM1A	RMI-28 Adapter only*
RM1B	STM RMI-28/LFB/IEC56-B14 Reducer
RM1C	STM RMI-28/LFB with 0.09kW Motor
RM2A	RMI-40 Adapter only*
RM2B	STM RMI-40/LFB/IEC63-B14 Reducer
RM2C	STM RMI-40/LFB/IEC71-B14 Reducer
RM2D	STM RMI-40/LFB with 0.18kW Motor
RM2E	STM RMI-40/LFB with 0.25kW Motor

*All Reducer/Motor adapters require Gear Ratio option to be 0.

2 Motor Brake

Code	Description
000	No Brake

3 Reducer Gear Ratios*

Code	Description	
	R180	STM RMI-28/40
0	N/A	N/A
A	10:1	10:1
B	15:1	15:1
C	20:1	20:1
D	25:1	28:1
E	30:1	40:1
F	40:1	49:1
G	50:1	56:1
H	60:1	70:1

*All Reducer/Motor adapters require Gear Ratio option to be 0.
Select Gear ratio column based on the reducer type selected.

4 Output Clutch & Settings

80RDM Metric Clutch Models	
Code	Description
0000	No Output Overload Clutch
M28DA	M2.8D W/54 Nm, Standard*
M28DB	M2.8D W/96 Nm, Standard*
M28DC	M2.8D W/147 Nm, Standard*
M28DD	M2.8D W/249 Nm, Standard*
M28DE	M2.8D W/350 Nm, Standard*
M28DF	M2.8D W/45 Nm, Standard*
M28DG	M2.8D W/79 Nm, Standard*
M28DH	M2.8D W/124 Nm, Standard*
M28DJ	M2.8D W/203 Nm, Standard*
M28DK	M2.8D W/54 Nm, Thru-Hole
M28DL	M2.8D W/96 Nm, Thru-Hole
M28DM	M2.8D W/147 Nm, Thru-Hole
M28DN	M2.8D W/249 Nm, Thru-Hole
M28DP	M2.8D W/350 Nm, Thru-Hole
M28DQ	M2.8D W/45 Nm, Thru-Hole
M28DR	M2.8D W/79 Nm, Thru-Hole
M28DS	M2.8D W/124 Nm, Thru-Hole
M28DT	M2.8D W/203 Nm, Thru-Hole
M28EA	M2.8D W/54 Nm, Standard, EZ*
M28EB	M2.8D W/96 Nm, Standard, EZ*
M28EC	M2.8D W/147 Nm, Standard, EZ*
M28ED	M2.8D W/249 Nm, Standard, EZ*
M28EE	M2.8D W/350 Nm, Standard, EZ*
M28EF	M2.8D W/45 Nm, Standard, EZ*
M28EG	M2.8D W/79 Nm, Standard, EZ*
M28EH	M2.8D W/124 Nm, Standard, EZ*
M28EJ	M2.8D W/203 Nm, Standard, EZ*
M28EK	M2.8D W/54 Nm, Thru-Hole, EZ
M28EL	M2.8D W/96 Nm, Thru-Hole, EZ
M28EM	M2.8D W/147 Nm, Thru-Hole, EZ
M28EN	M2.8D W/249 Nm, Thru-Hole, EZ
M28EP	M2.8D W/350 Nm, Thru-Hole, EZ
M28EQ	M2.8D W/45 Nm, Thru-Hole, EZ
M28ER	M2.8D W/79 Nm, Thru-Hole, EZ
M28ES	M2.8D W/124 Nm, Thru-Hole, EZ
M28ET	M2.8D W/203 Nm, Thru-Hole, EZ

*Cannot be used with center post option P

5 Motor Control

Code	Description
000	NO MOTOR CONTROL
A01	(AC) PowerFlex 523 1HP 120V 1Ph
A02	(AC) PowerFlex 523 1HP 240V 1Ph
A03	(AC) PowerFlex 523 1HP 480V 3Ph
A04	(AC) PowerFlex 525 1HP 120V 1Ph
A05	(AC) PowerFlex 525 1HP 240V 1Ph
A06	(AC) PowerFlex 525 1HP 480V 3Ph
D01	(DC) Varipak 1HP 90VDC Uni-Directional
D02	(DC) Varipak 1HP 90VDC Bi-Directional
D03	(DC) Varipak 2HP 180VDC Uni-Directional
D04	(DC) Varipak 2HP 180VDC Bi-Directional

Maximum Inertia x 1000 kg-cm ² [lb-in ²] for standard package							
Stops	Motion Time [seconds]						
	0.458	0.611	0.764	0.917	1.222	1.528	1.833
2	0 [0]	3 [1]	6 [2]	15 [5]	29 [10]	47 [16]	67 [23]
3	3 [1]	9 [3]	20 [7]	32 [11]	61 [21]	94 [32]	138 [47]
4	6 [2]	18 [6]	38 [13]	67 [23]	135[46]	217 [74]	304 [104]
6	15 [5]	38 [13]	82 [28]	126 [43]	246 [84]	401 [137]	559 [191]
8	20 [7]	44 [15]	73 [25]	114 [39]	222 [76]	372 [127]	559 [191]
12	50 [17]	99 [34]	167 [57]	258 [88]	497 [170]	559 [191]	559 [191]
16	47 [16]	91 [31]	152 [52]	231 [79]	448 [153]	559 [191]	559 [191]
Reducer Ratio							
	15	20	25	30	40	50	60

Contact your DESTACO sales representative for more information.

Features

- R180 Reducer (Ratios from 15:1 to 60:1)
 - Double Extended Worm Shaft (Input)
 - Worm Shaft Handwheel
- Double Extended Camshaft (Input Shaft)
- Center Thru Hole (Ø70 mm [Ø2.76 in.])
- 1/3 HP AC Drive Package with Inverter Duty Motor and IM-pAC AC Drive (up to 60 cpm)
- Cycle Cam and Limit Switch Mounted to Camshaft
- Right Hand Cam
- Universal Mounting Capability

Output Load Capacity (loads carried during index):
 Radial 3358 N [755 lbs]
 Thrust/Axial 8385 N [1885 lbs]
 Moment 213 N-m [1885 in-lb]

Typical Application Dial Diameter: 203 mm [8 in] to 711 mm [28 in]

Accuracy ±44 arcsec / ±0,08 mm [±.003in] at 355,6 mm [14in] Radius

Repeatability ±11 arcsec / ±0,018 mm [±.0007in] at 355,6 mm [14in] Radius

Optional Accessories

- 1/3 HP DC Motor
- Varipak DC Motor Control (up to 30 cpm)
- Output Mechanical Overload Clutch
 - See Page 9
- EZ Mount Dial Adapter
- Stationary Center Post
- Dual Cam and Limit Switch
- Electric Clutch-Brake
- Left Hand Cam

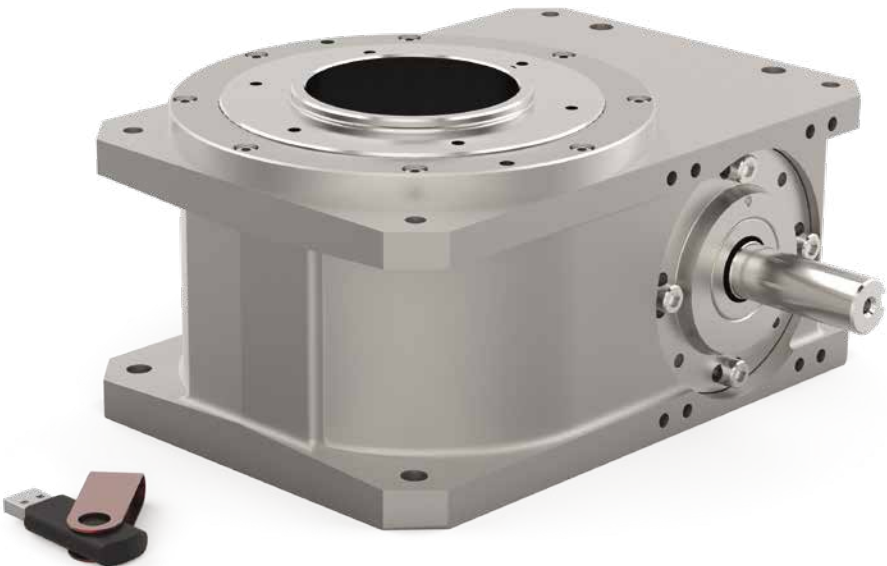

80RDM SERIES

Rotary Index Drive | Product Overview | Technical Specifications

Proximity Switch

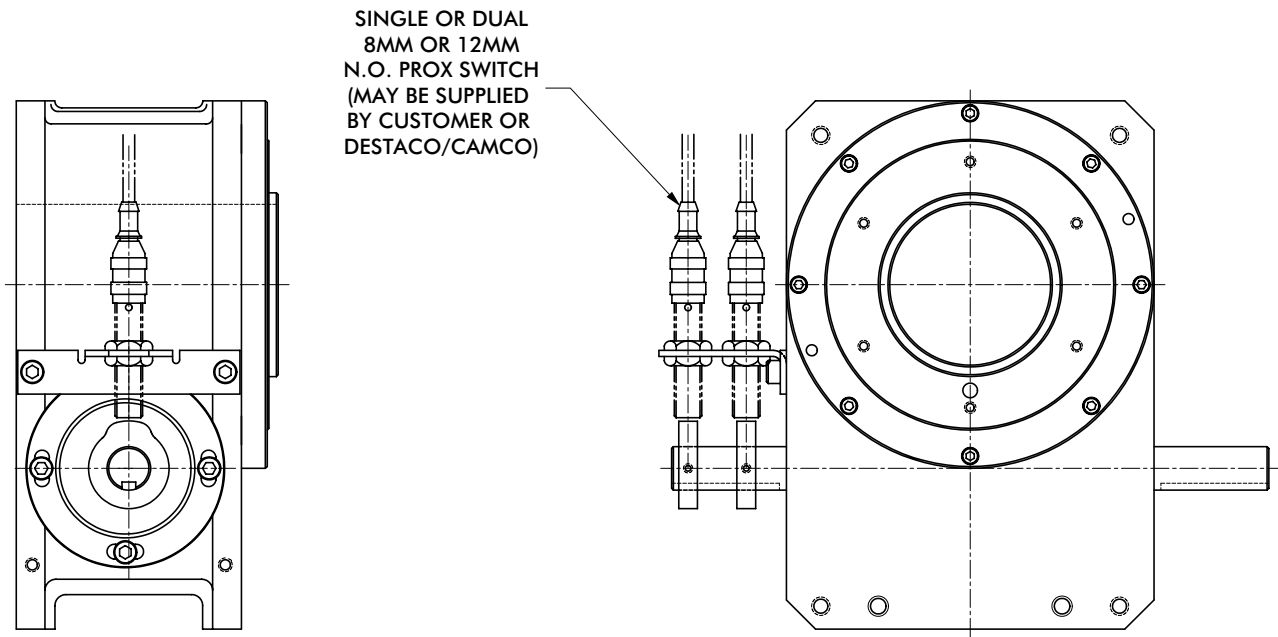

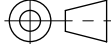
mm [INCH]

 THIRD ANGLE
 PROJECTION

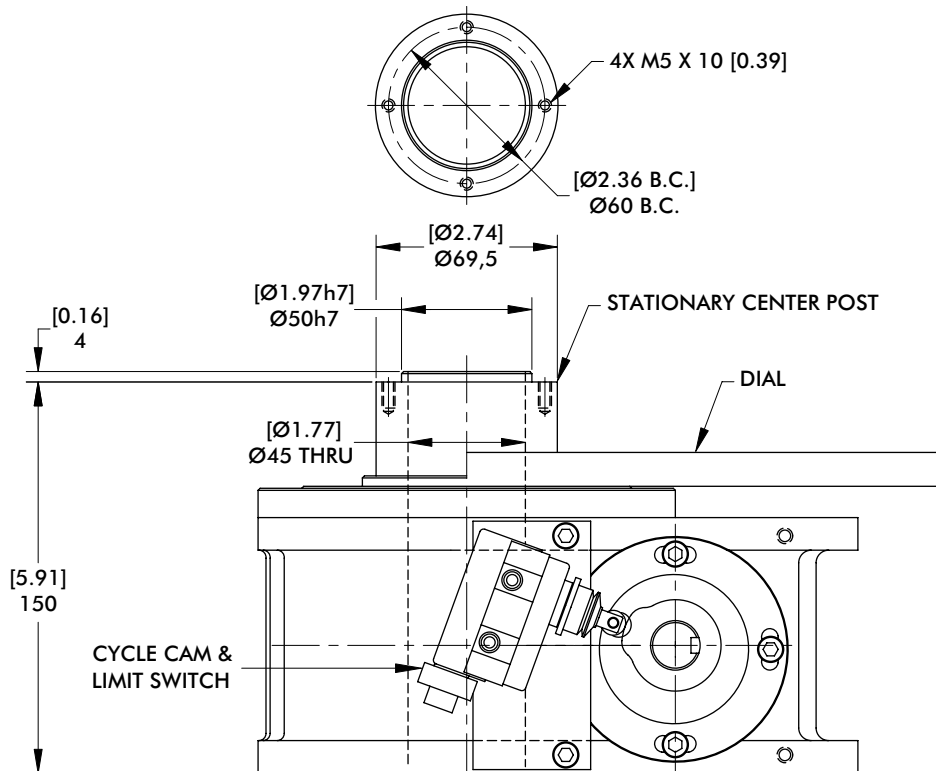
Center Post



8ORDM SERIES

Rotary Index Drive | Dimensions

2.8D Overload Clutch

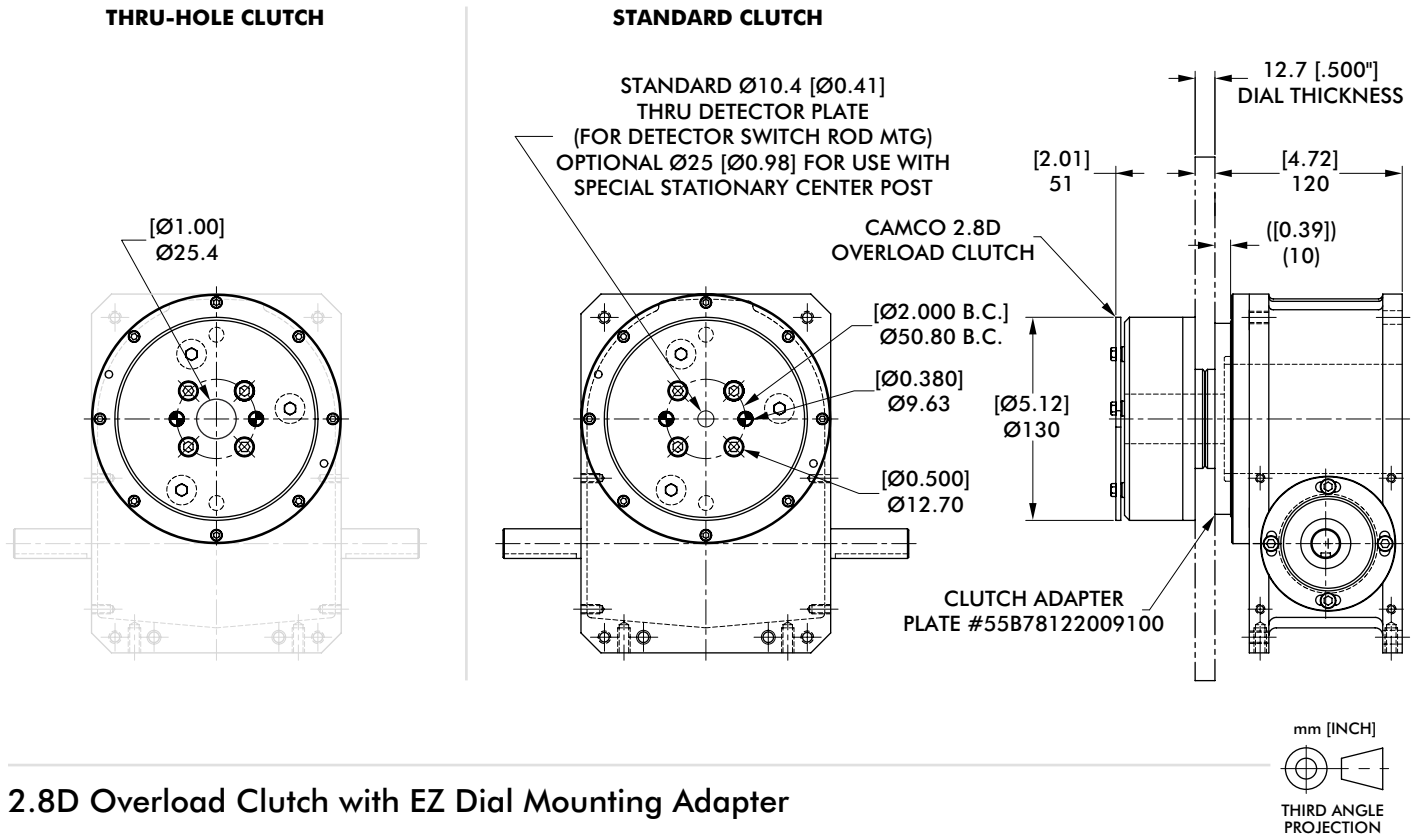

2.8D Overload Clutch with EZ Dial Mounting Adapter

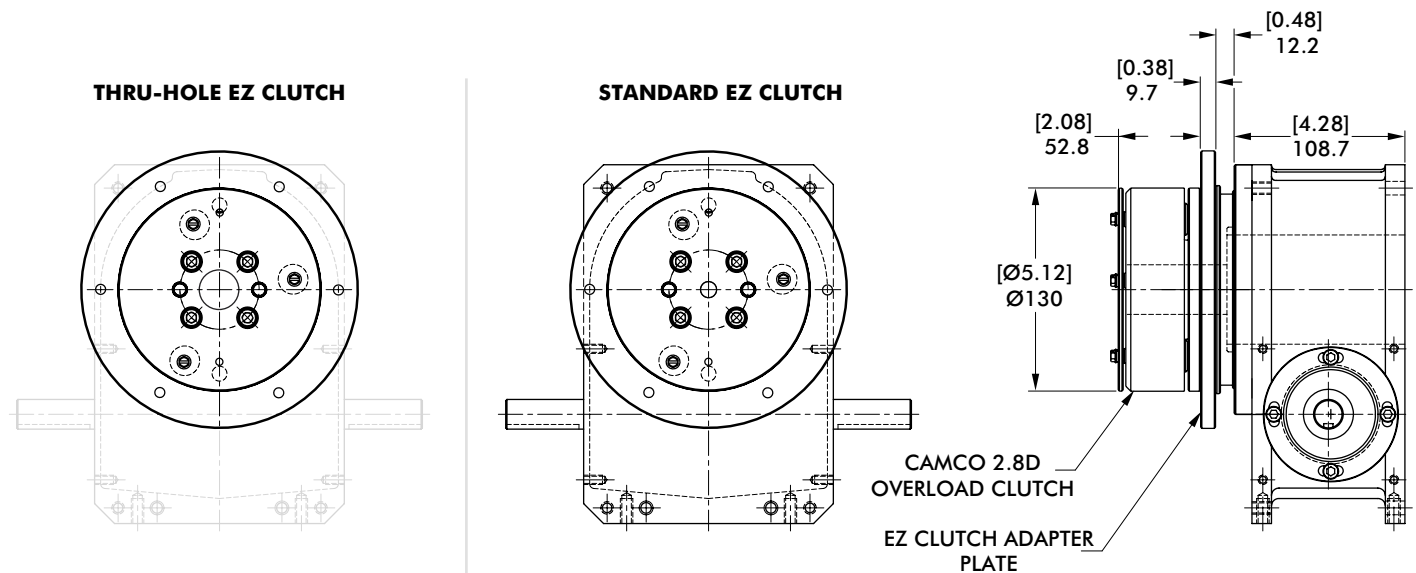

Model	Internal Inertia kg-m ² [lb-in ²]	Torque Setting N-m [in-lb]
2.8D	0,0085 [29]	45, 54, 79, 96, 124, 147, 203, 249, 350 [400, 480, 700, 850, 1100, 1300, 1800, 2200, 3100]

80RDM SERIES

Notes

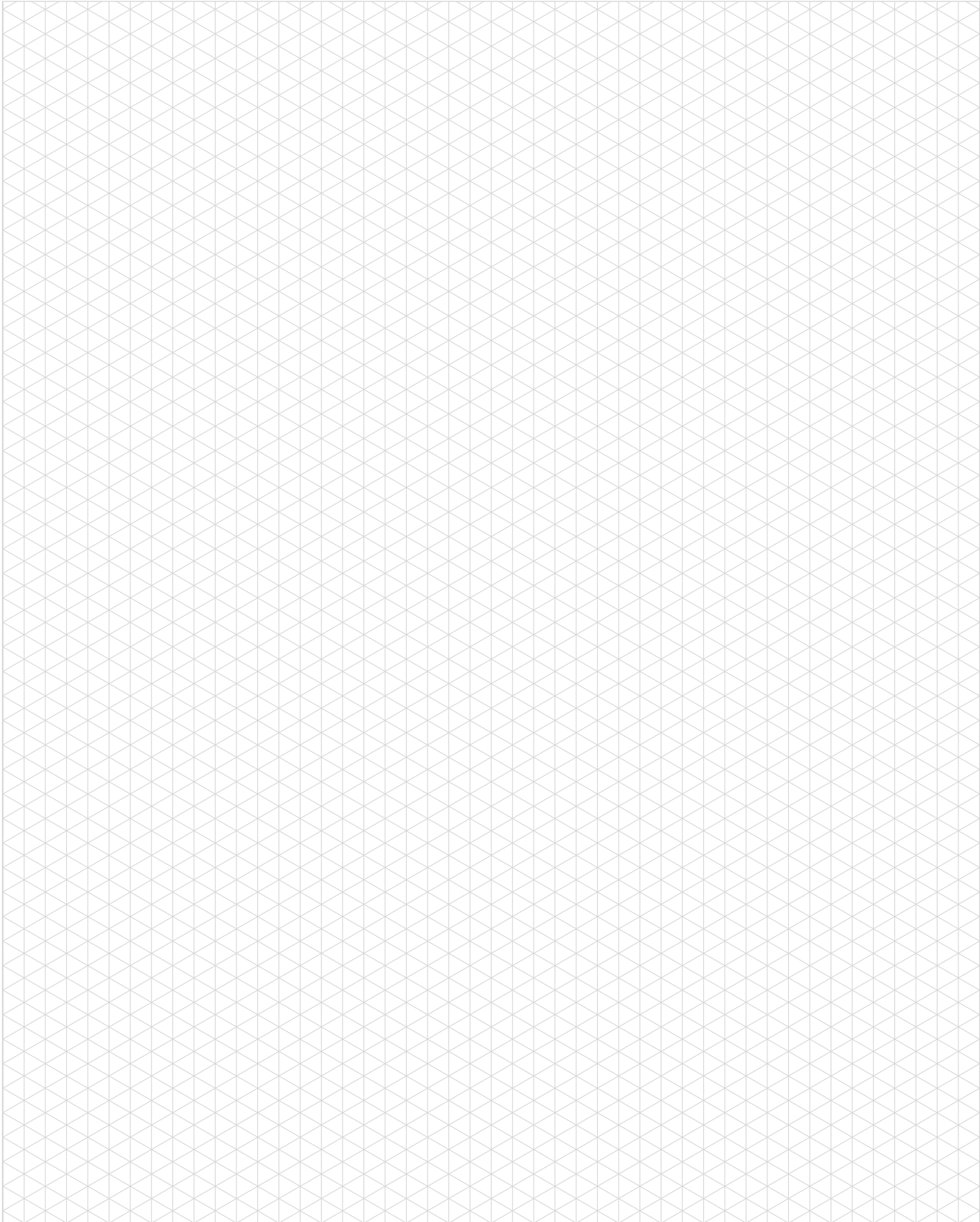

Maximum Inertia x 1000 kg-cm ² [lb-in ²] for standard package							
Stops	Motion Time [seconds]						
	0.458	0.611	0.764	0.917	1.222	1.528	1.833
2	0 [0]	3 [1]	6 [2]	15 [5]	32 [11]	50 [17]	70 [24]
3	3 [1]	9 [3]	20 [7]	35 [12]	82 [28]	123 [42]	170 [58]
4	6 [2]	18 [6]	38 [13]	67 [23]	152 [52]	228 [78]	310 [106]
6	15 [5]	41 [14]	82 [28]	149 [51]	328 [112]	492 [168]	667 [228]
8	29 [10]	73 [25]	149 [51]	263 [90]	582 [199]	875 [299]	1188 [406]
12	64 [22]	167 [57]	337 [115]	597 [204]	1314 [449]	1399 [478]	1399 [478]
16	117 [40]	296 [101]	600 [205]	1056 [361]	1399 [478]	1399 [478]	1399 [478]
Reducer Ratio							
	15	20	25	30	40	50	60

Other Motions (stops and index periods) available. Contact your DESTACO sales representative for more information.

Features

- R180 Reducer (Ratios from 15:1 to 60:1)
 - Double Extended Worm Shaft (Input)
 - Worm Shaft Handwheel
- Double Extended Camshaft (Input Shaft)
- Center Thru Hole (Ø44,45 [Ø1.75 in.])
- 1/3 HP AC Drive Package with Inverter Duty Motor and IM-pAC AC Drive (up to 60 cpm)
- Cycle Cam and Limit Switch Mounted to Camshaft
- Right Hand Cam

Output Load Capacity (loads carried during index):

Radial	4204 N [945 lbs]
Thrust/Axial	10498 N [2360 lbs]
Moment	373 N-m [3305 in-lb]

Typical Application Dial Diameter:

305 mm [12 in] to 914 mm [36 in]

Accuracy

±39 arcsec / ±0,08 mm [±.003in]
at 457,2 mm [18in] Radius

Repeatability

±10 arcsec / ±0,023 mm [±.0009in]
at 457,2 mm [18in] Radius

Optional Accessories

- 1/3 hp DC Motor
- Varipak DC Motor Control (up to 30 cpm)
- Output Mechanical Overload Clutch
 - See Page 15
- EZ Mount Dial Adapter
- Stationary Center Post
- Dual Cam and Limit Switch
- Relief in Dwell for shot-pin applications
- Left Hand Cam



601RDM SERIES

Rotary Index Drive | Dimensions

Proximity Switch

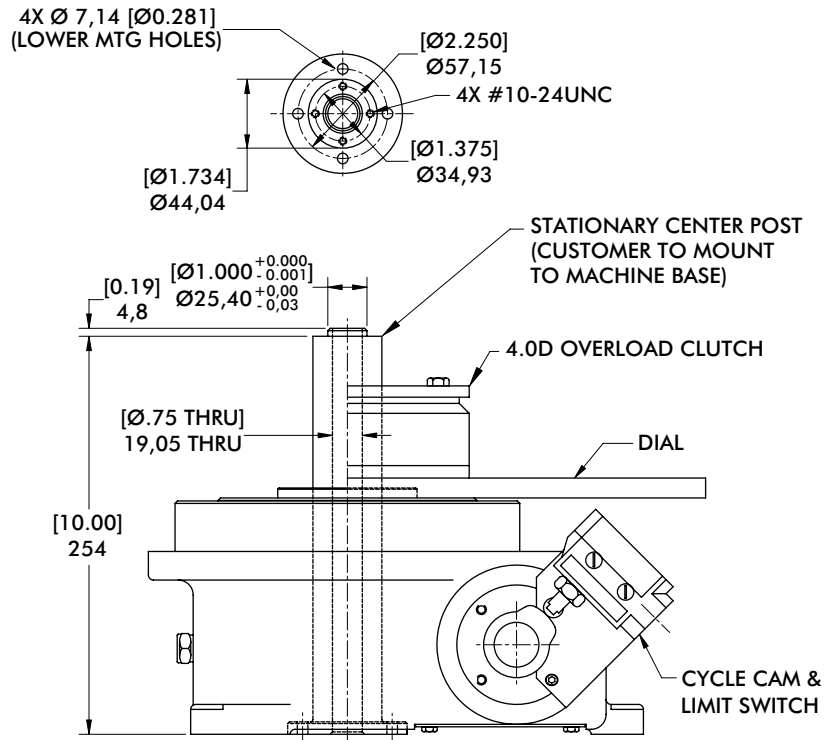

mm [INCH]

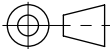

THIRD ANGLE
PROJECTION

Center Post

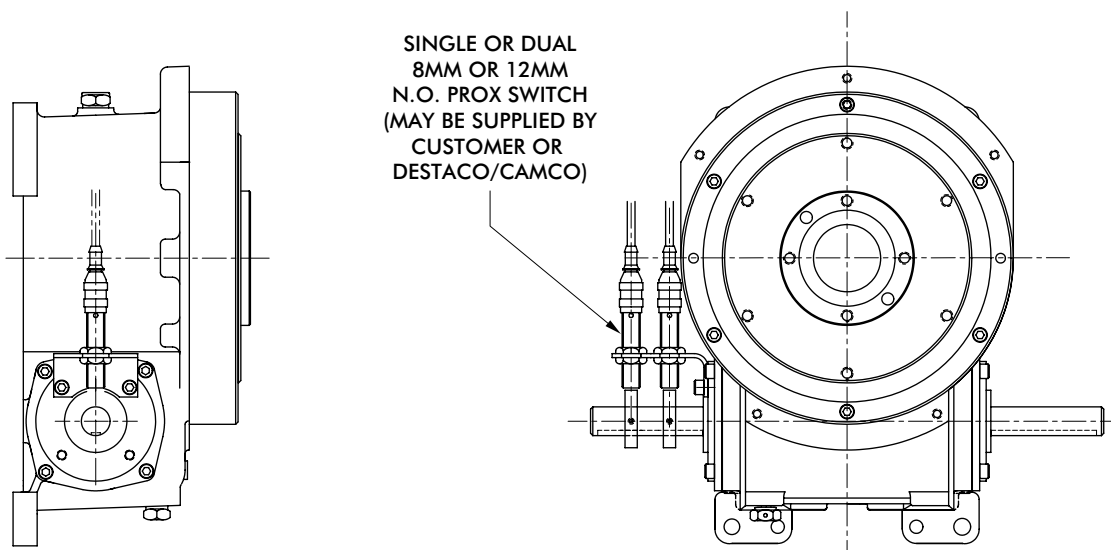

601RDM SERIES

Rotary Index Drive | Dimensions

4.0D Overload Clutch

THRU-HOLE CLUTCH

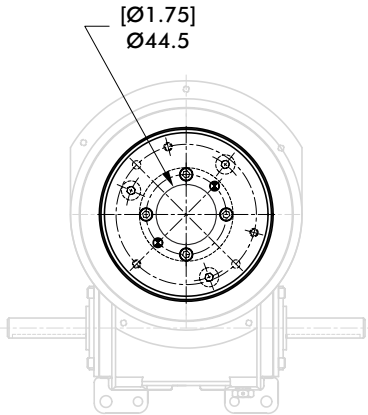

STANDARD CLUTCH

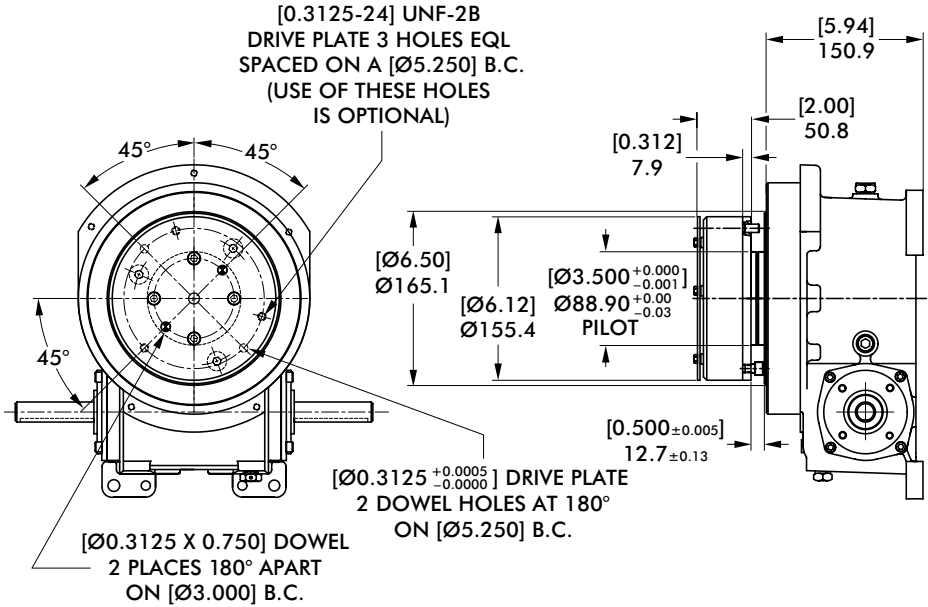

mm [INCH]
THIRD ANGLE
PROJECTION

4.0D Overload Clutch with EZ Dial Mounting Adapter

THRU-HOLE EZ CLUTCH

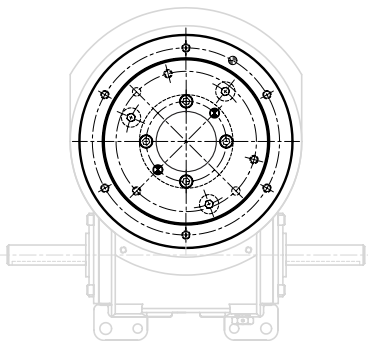

STANDARD EZ CLUTCH

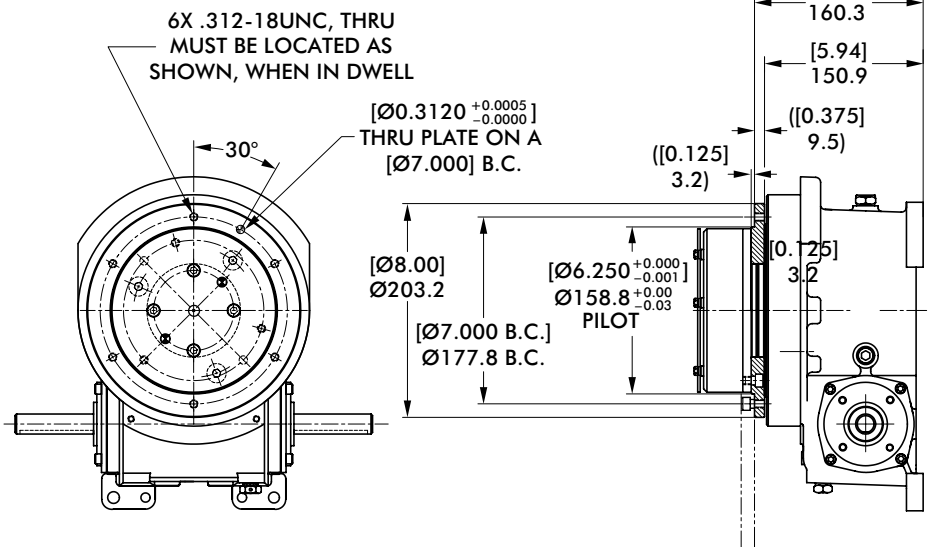

Model	Internal Inertia kg-m ² [lb-in ²]	Torque Setting N-m [in-lb]
4.0D	0,0202 [69]	47, 70, 85, 130, 198, 333, 452 [420, 620, 750, 1150, 1750, 2950, 4000]

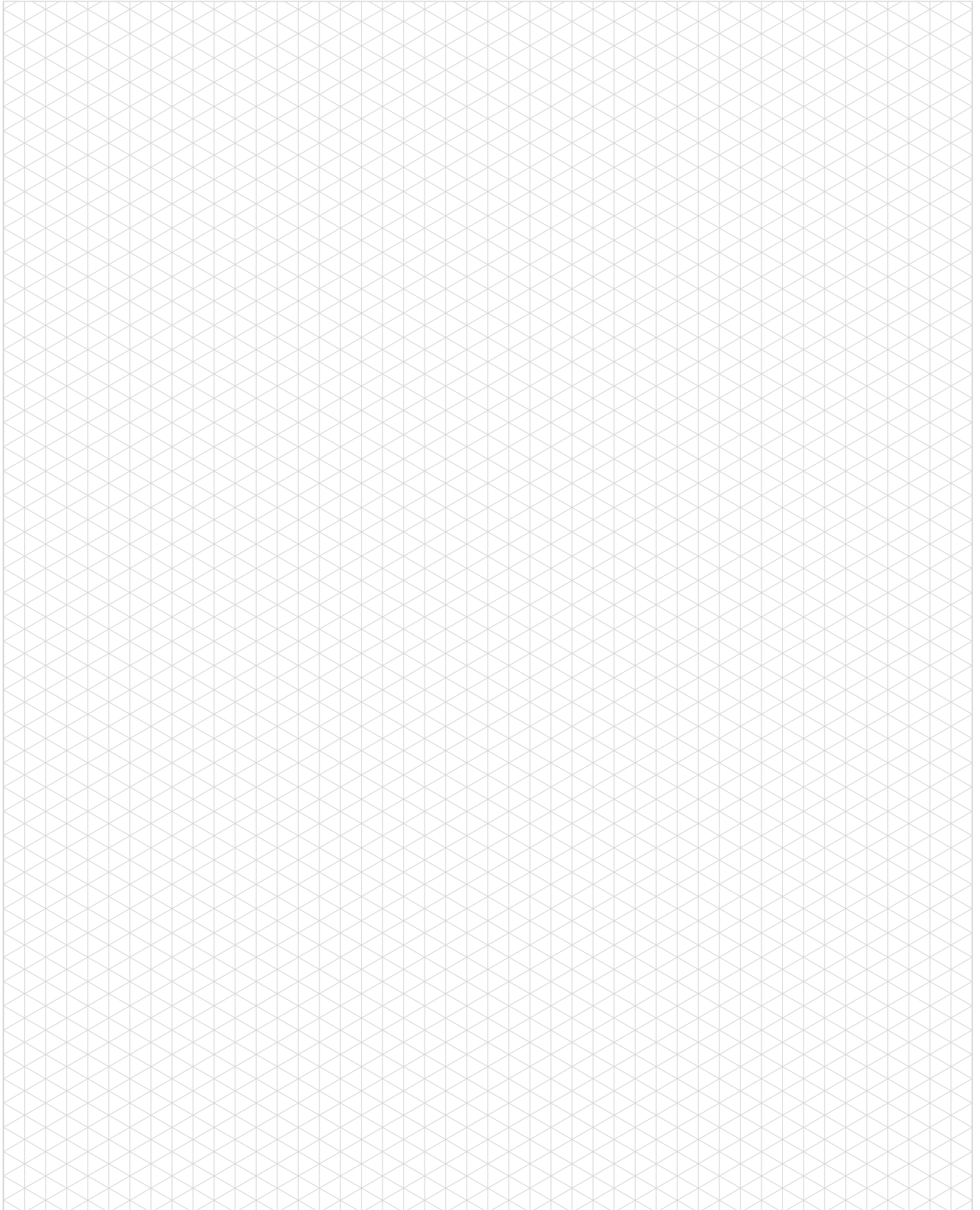

902RDM SERIES

Rotary Index Drive | How To Order

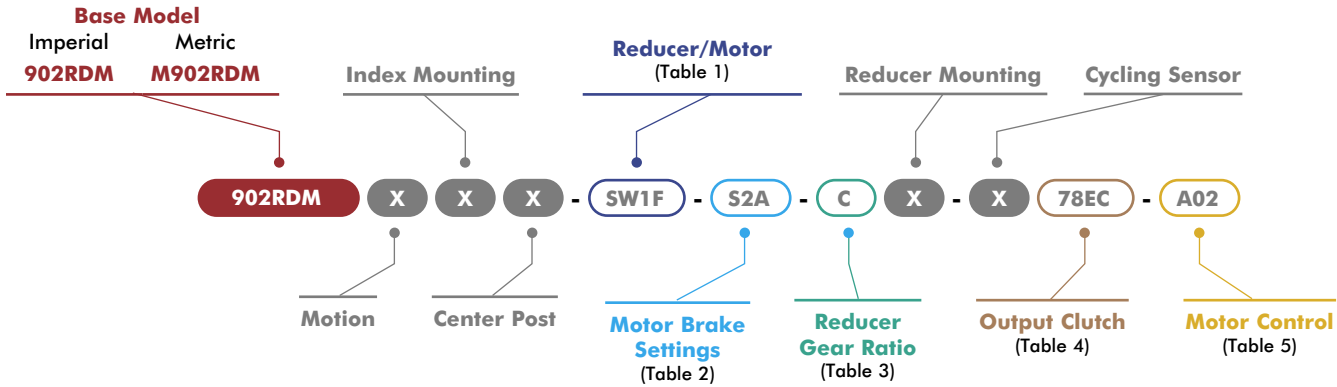

X = See Page 3 for option information.

1 Reducer/Motor Options

Code	Description
0000	No Reducer or Motor*
R225 Motors	
R2XX	R225 Adapter only*
R2SA	R225 Reducer 56 ADAPTER & CPLG, Single Extended Worm
R2SB	R225 Reducer 145TC ADAPTER & CPLG, Single Extended Worm (No Motor)
R2SC	R225 Reducer with 0.5HP 56C 230/460V AC Motor, Single Extended Worm
R2SD	R225 Reducer with 1.0HP 56C 230/460V AC Motor, Single Extended Worm
R2SE	R225 Reducer with 1.0HP 56C 90V DC Motor, Single Extended Worm
R2SF	R225 Reducer with 1.0HP 56C 180V DC Motor, Single Extended Worm
R2DA	R225 Reducer 56 ADAPTER & CPLG, Double Extended Worm
R2DB	R225 Reducer 145TC ADAPTER & CPLG, Double Extended Worm (No Motor)
R2DC	R225 Reducer with 0.5HP 56C 230/460V AC Motor, Double Extended Worm
R2DD	R225 Reducer with 1.0HP 56C 230/460V AC Motor, Double Extended Worm
R2DE	R225 Reducer with 1.0HP 56C 90V DC Motor, Double Extended Worm
R2DF	R225 Reducer with 1.0HP 56C 180V DC Motor, Double Extended Worm
SEW KH37 Motors	
SW1E	KH37 Adapter only*
SW1F	SEW KH37DRN80M4/.75Kw Motor/Brake Motor (60Hz, 230/460V)
SW1G	SEW KH37DRN80M4/.75Kw Motor/Brake Motor (50Hz, 400V)
SW1H	SEW KH37DRN80M4/.75Kw Motor/Brake Motor (60Hz, 575V)
SW1J	SEW KH37DRN90L4/1.5Kw Motor/Brake Motor (60Hz, 230/460V)
SW1K	SEW KH37DRN90L4/1.5Kw Motor/Brake Motor (50Hz, 400V)
SW1L	SEW KH37DRN90L4/1.5Kw Motor/Brake Motor (60Hz, 575V)
STM RMI-63/70 Motors	
RM4A	STM RMI-63 Adapter only*
RM4B	STM RMI-63 IEC80-B14 Reducer
RM4C	STM RMI-63 IEC90-B14 Reducer
RM4D	STM RMI-63 Reducer with .75kW Motor
RM4E	STM RMI-63 Reducer with 1.5kW Motor
RM5A	STM RMI-70 Adapter only*
RM5B	STM RMI-70 IEC80-B14 Reducer
RM5C	STM RMI-70 IEC90-B14 Reducer
RM5D	STM RMI-70 Reducer with .75kW Motor
RM5E	STM RMI-70 Reducer with 1.5kW Motor

*All Reducer/Motor adapters require Gear Ratio option to be 0.

2 Motor Brake*

Code	Description
000	No Brake
S1A	1.69 Nm (BE05)
S1B	2.49 Nm (BE05)
S1C	3.50 Nm (BE05)
S2A	4.97 Nm (BE1)
S2B	7.01 Nm (BE1)
S2C	9.94 Nm (BE1)
S3A	9.94 Nm (BE2)
S3B	14.01 Nm (BE2)
S3C	20.00 Nm (BE2)

*SEW Motor brake setting options only. All other motors use option code 000.

3 Reducer Gear Ratios*

Code	Description	R225	SEW KH37	STM RMI-63/70
0	N/A	N/A	N/A	N/A
A	10:1	10.49:1	10:1	
B	15:1	15.31:1	15:1	
C	20:1	20.19:1	20:1	
D	25:1	29.96:1	28:1	
E	30:1	37.97:1	40:1	
F	40:1	49.79:1	49:1	
G	50:1	58.60:1	56:1	
H	60:1	67.80:1	70:1	

*All Reducer/Motor adapters require Gear Ratio option to be 0.
Select Gear ratio column based on the reducer type selected.

4 Output Clutch & Settings

902RDM Imperial Clutch Models		M902RDM Metric Clutch Models	
Code	Description	Code	Description
0000	No Output Overload Clutch	0000	No Output Overload Clutch
78DA	7.8D/3200 In-Lb, Standard*	M78DA	M7.8D/360 Nm, Standard*
78DB	7.8D/7200 In-Lb, Standard*	M78DB	M7.8D/815 Nm, Standard*
78DC	7.8D/10000 In-Lb, Standard*	M78DC	M7.8D/1130 Nm, Standard*
78DD	7.8D/1400 In-Lb, Standard*	M78DD	M7.8D/160 Nm, Standard*
78DE	7.8D/1700 In-Lb, Standard*	M78DE	M7.8D/192 Nm, Standard*
78DF	7.8D/2600 In-Lb, Standard*	M78DF	M7.8D/295 Nm, Standard*
78DG	7.8D/4200 In-Lb, Standard*	M78DG	M7.8D/475 Nm, Standard*
78DH	7.8D/5000 In-Lb, Standard*	M78DH	M7.8D/566 Nm, Standard*
78DJ	7.8D/3200 In-Lb, Thru-Hole	M78DJ	M7.8D/360 Nm, Thru-Hole
78DK	7.8D/7200 In-Lb, Thru-Hole	M78DK	M7.8D/815 Nm, Thru-Hole
78DL	7.8D/10000 In-Lb, Thru-Hole	M78DL	M7.8D/1130 Nm, Thru-Hole
78DM	7.8D/1400 In-Lb, Thru-Hole	M78DM	M7.8D/160 Nm, Thru-Hole
78DN	7.8D/1700 In-Lb, Thru-Hole	M78DN	M7.8D/192 Nm, Thru-Hole
78DP	7.8D/2600 In-Lb, Thru-Hole	M78DP	M7.8D/295 Nm, Thru-Hole
78DQ	7.8D/4200 In-Lb, Thru-Hole	M78DQ	M7.8D/475 Nm, Thru-Hole
78DR	7.8D/5000 In-Lb, Thru-Hole	M78DR	M7.8D/566 Nm, Thru-Hole
78EA	7.8D/3200 In-Lb, Standard, EZ*	M78EA	M7.8D/360 Nm, Standard, EZ*
78EB	7.8D/7200 In-Lb, Standard, EZ*	M78EB	M7.8D/815 Nm, Standard, EZ*
78EC	7.8D/10000 In-Lb, Standard, EZ*	M78EC	M7.8D/1130 Nm, Standard, EZ*
78ED	7.8D/1400 In-Lb, Standard, EZ*	M78ED	M7.8D/160 Nm, Standard, EZ*
78EE	7.8D/1700 In-Lb, Standard, EZ*	M78EE	M7.8D/192 Nm, Standard, EZ*
78EF	7.8D/2600 In-Lb, Standard, EZ*	M78EF	M7.8D/295 Nm, Standard, EZ*
78EG	7.8D/4200 In-Lb, Standard, EZ*	M78EG	M7.8D/475 Nm, Standard, EZ*
78EH	7.8D/5000 In-Lb, Standard, EZ*	M78EH	M7.8D/566 Nm, Standard, EZ*
78EJ	7.8D/3200 In-Lb, Thru-Hole, EZ	M78EJ	M7.8D/360 Nm, Thru-Hole, EZ
78EK	7.8D/7200 In-Lb, Thru-Hole, EZ	M78EK	M7.8D/815 Nm, Thru-Hole, EZ
78EL	7.8D/10000 In-Lb, Thru-Hole, EZ	M78EL	M7.8D/1130 Nm, Thru-Hole, EZ
78EM	7.8D/1400 In-Lb, Thru-Hole, EZ	M78EM	M7.8D/160 Nm, Thru-Hole, EZ
78EN	7.8D/1700 In-Lb, Thru-Hole, EZ	M78EN	M7.8D/192 Nm, Thru-Hole, EZ
78EP	7.8D/2600 In-Lb, Thru-Hole, EZ	M78EP	M7.8D/295 Nm, Thru-Hole, EZ
78EQ	7.8D/4200 In-Lb, Thru-Hole, EZ	M78EQ	M7.8D/475 Nm, Thru-Hole, EZ
78ER	7.8D/5000 In-Lb, Thru-Hole, EZ	M78ER	M7.8D/566 Nm, Thru-Hole, EZ

*Cannot be used with center post options P and B.

5 Motor Control

Code	Description
000	NO MOTOR CONTROL
A01	120V 1Ph
A02	(AC) PowerFlex 523 1HP
A03	240V 1Ph
A04	480V 3Ph
A05	120V 1Ph
A06	(AC) PowerFlex 525 1HP
A07	240V 1Ph
A08	480V 3Ph
A09	(AC) PowerFlex 523 2HP
A10	240V 3Ph
A11	(AC) PowerFlex 525 2HP
A12	480V 3Ph
D01	Uni-Directional
D02	(DC) Varipak 1HP 90VDC
D03	Bi-Directional
D04	(DC) Varipak 2HP 180VDC
D05	Uni-Directional
D06	Bi-Directional

Maximum Inertia x 1000 kg-cm ² [lb-in ²] for standard package							
Stops	Motion Time [seconds]						
	0.458	0.611	0.764	0.917	1.222	1.528	1.833
2	3 [1]	9 [3]	20 [7]	35 [12]	76 [26]	117 [40]	161 [55]
3	12 [4]	32 [11]	67 [23]	120 [41]	246 [84]	369 [126]	509 [174]
4	23 [8]	59 [20]	120 [41]	214 [73]	439 [150]	661 [226]	907 [310]
6	53 [18]	129 [44]	263 [90]	462 [158]	945 [323]	1419 [485]	1952 [667]
8	94 [32]	234 [80]	468 [160]	825 [282]	1683 [575]	2528 [864]	3474 [1187]
12	214 [73]	530 [181]	989 [338]	1425 [487]	2531 [865]	3956 [1352]	5701 [1948]
16	380 [130]	916 [313]	1481 [506]	2130 [728]	3790 [1295]	5923 [2024]	8528 [2914]
Reducer Ratio							
	15	20	25	30	40	50	60

Other Motions (stops and index periods) available. Contact your DESTACO sales representative for more information.

Features

- R225 Reducer (Ratios from 15:1 to 60:1)
- Single Extended wormshaft (Standard)
- Double Extended Camshaft (Input Shaft)
- Center Thru Hole (Ø57,15 mm [Ø2.25 in.])
- 1 HP AC Drive Package with Inverter Duty Motor and IM-pAC AC Drive (up to 60 cpm)
- Cycle Cam and Limit Switch Mounted to Camshaft
- Right Hand Cam

Output Load Capacity (loads carried during index):

Radial	15747 N [3540 lbs]
Thrust/Axial	31138 N [7000 lbs]
Moment	2443 N-m [21620 in-lb]

Typical Application

Dial Diameter: 508 mm [20 in] to 1219 mm [48 in]

Accuracy ±27 arcsec / ±0,08 mm [±.003in] at 609,6 mm [24in] Radius

Repeatability ±7 arcsec / ±0,020 mm [±.0008in] at 609,6 mm [24in] Radius

Optional Accessories

- 1 hp DC Motor
- Varipak DC Motor Control (up to 30 cpm)
- Output Mechanical Overload Clutch
– See Page 21
- EZ Mount Dial Adapter
- Stationary Center Post
- Dual Cam and Limit Switch
- Base Riser Blocks
- Electric Clutch-Brake
- Left Hand Cam
- Relief in Dwell for shot-pin applications



902RDM SERIES

Rotary Index Drive | Dimensions

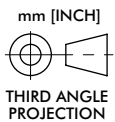
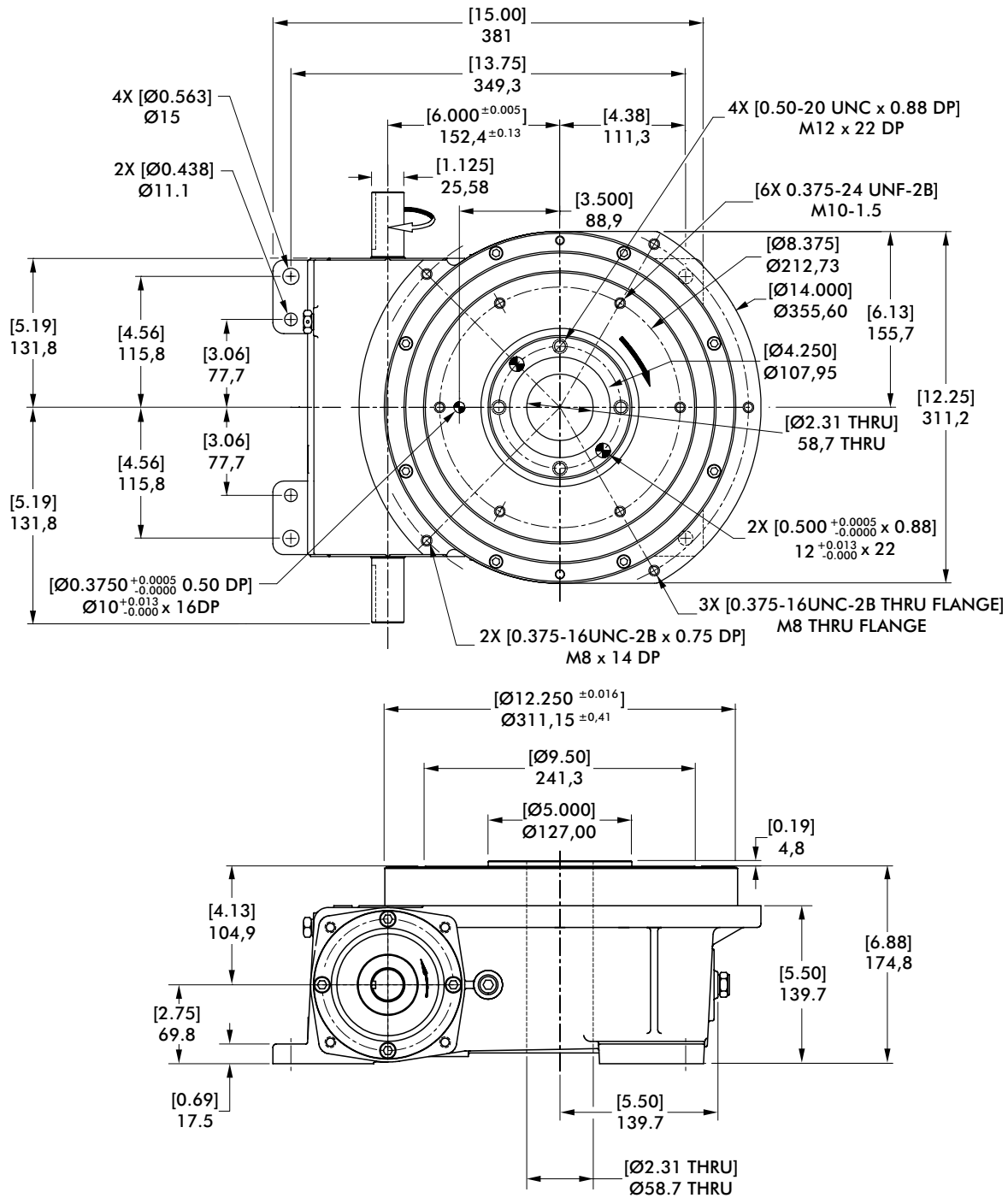

902RDM SERIES

Rotary Index Drive | Product Overview | Technical Specifications

Center Post

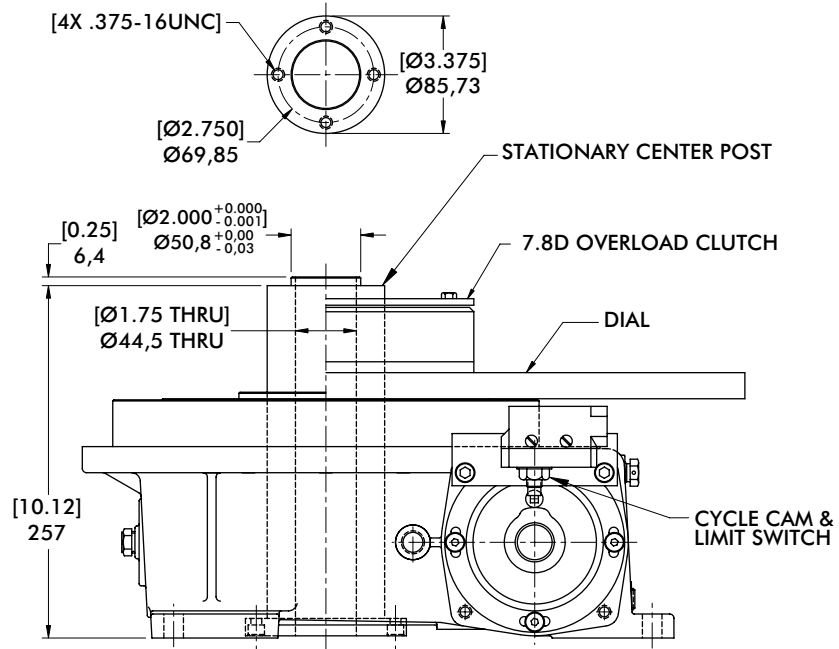

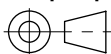
mm [INCH]

 THIRD ANGLE
 PROJECTION

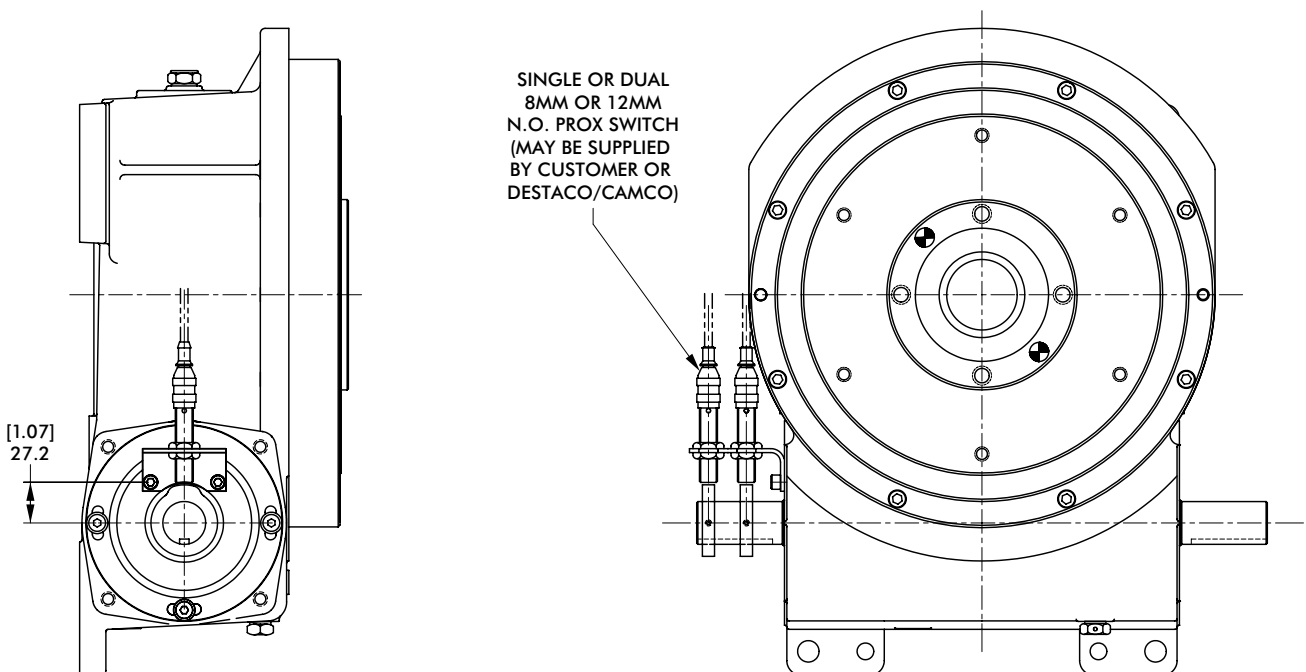
Proximity Switch



902RDM SERIES

Rotary Index Drive | Dimensions

7.8D Overload Clutch

THRU-HOLE CLUTCH

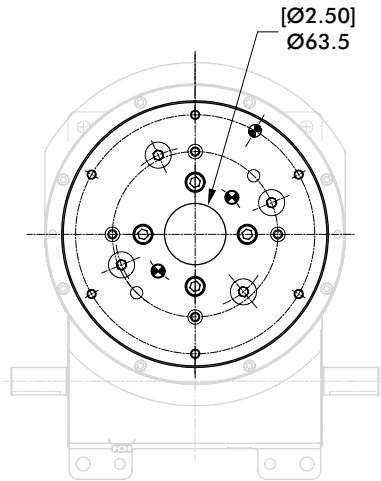

STANDARD CLUTCH

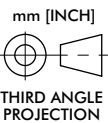
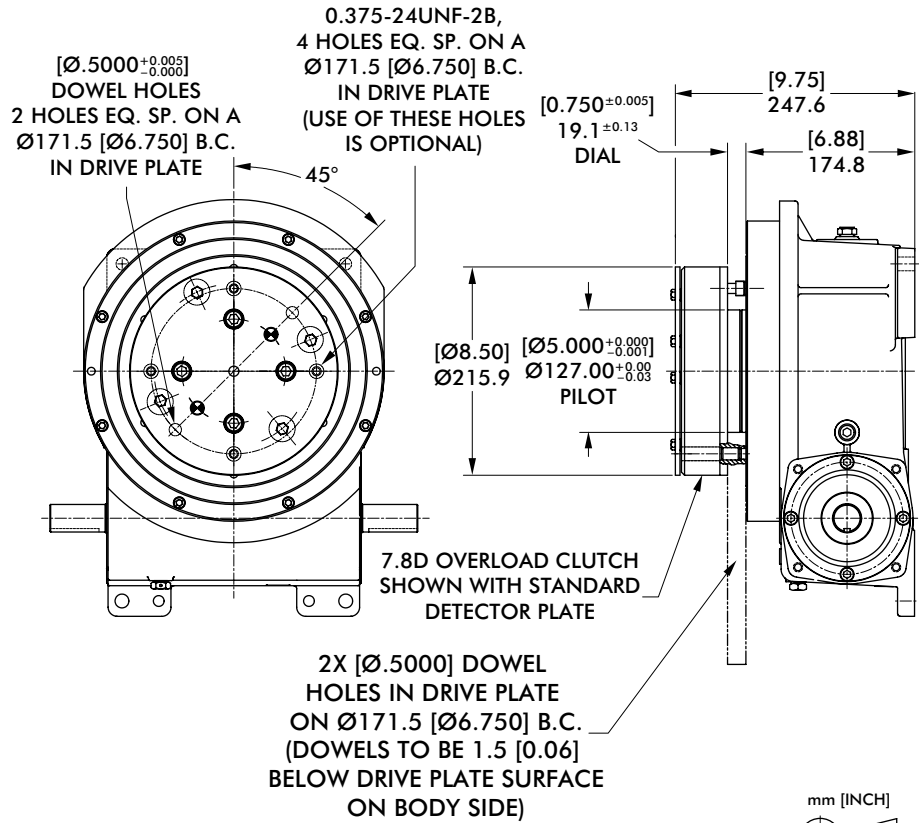

7.8D Overload Clutch with EZ Dial Mounting Adapter

THRU-HOLE EZ CLUTCH

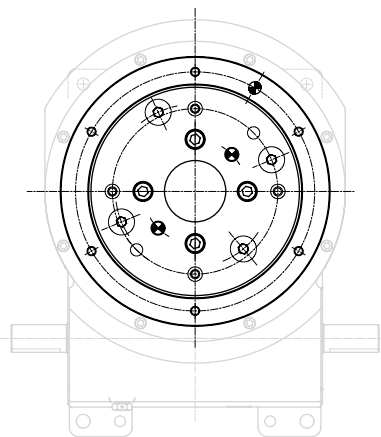

STANDARD EZ CLUTCH

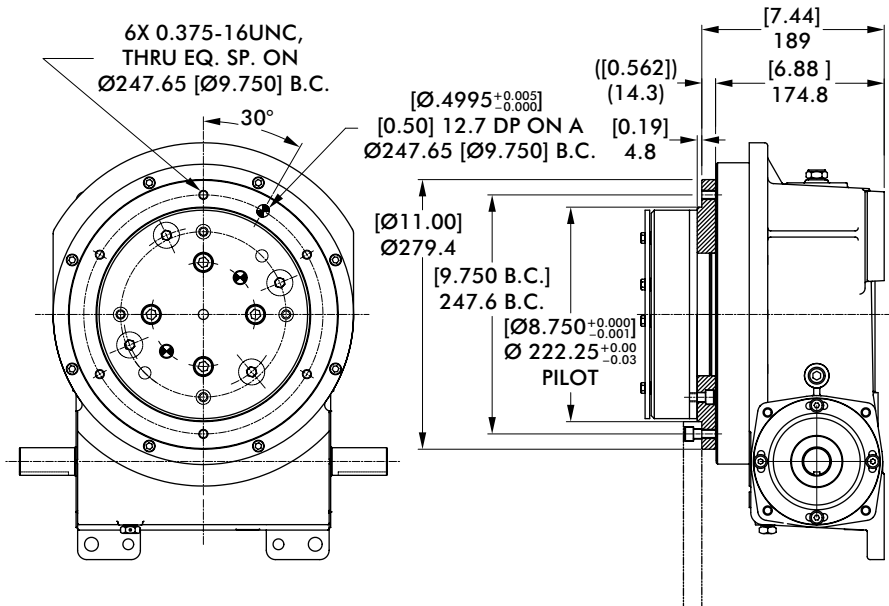

Model	Internal Inertia kg-m ² [lb-in ²]	Torque Setting N-m [in-lb]
7.8D	0,0778 [266]	158, 192, 294, 362, 475, 565, 813, 1130 [1400, 1700, 2600, 3200, 4200, 5000, 7200, 10000]

902RDM SERIES

Notes

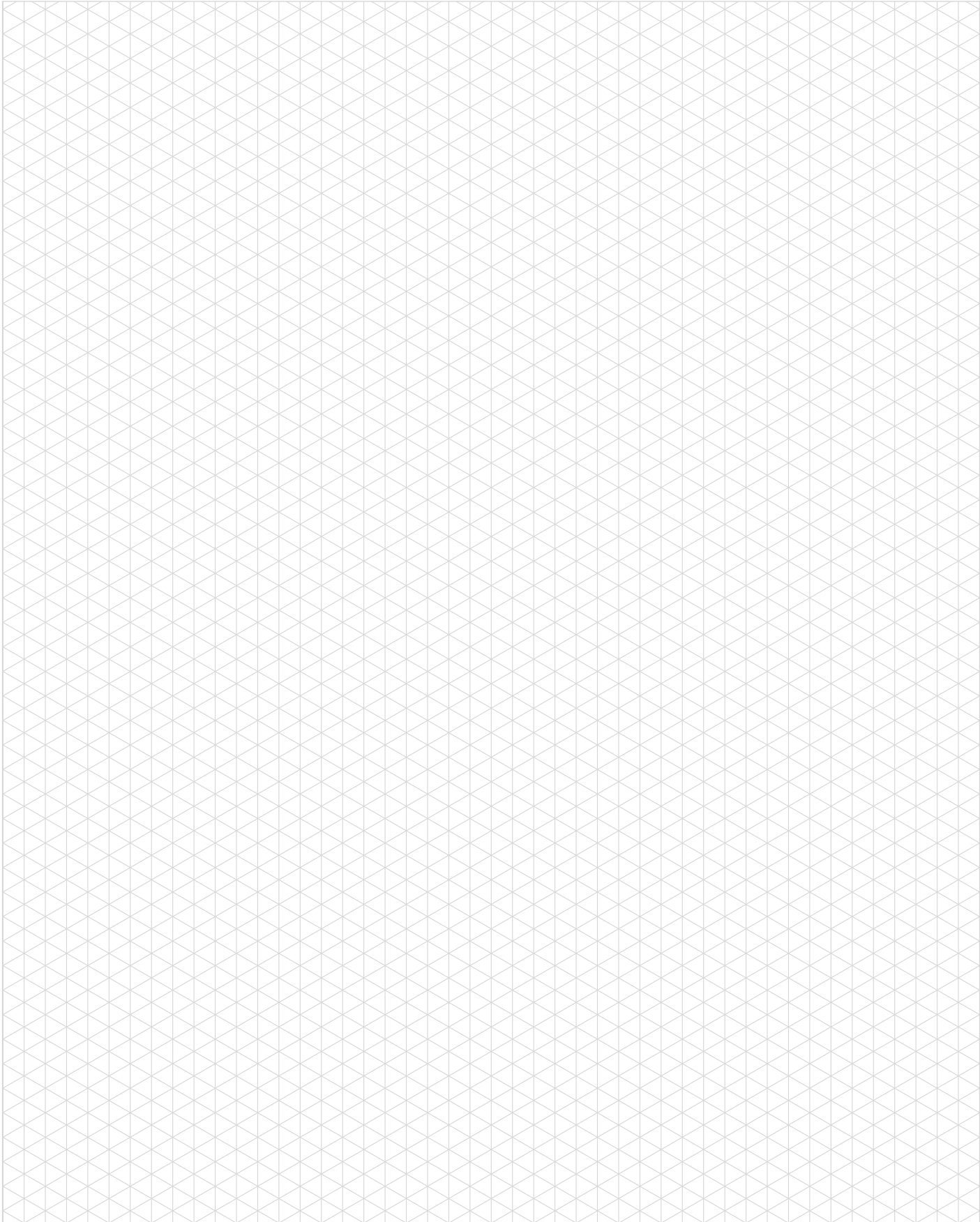

Maximum Inertia x 1000 kg-cm ² [lb-in ²] for standard package							
Stops	Motion Time [seconds]						
	0.458	0.611	0.764	0.917	1.222	1.528	1.833
2	3 [1]	15 [5]	32 [11]	64 [22]	176 [60]	342 [117]	518 [177]
3	18 [6]	38 [13]	79 [27]	152 [52]	401 [137]	775 [265]	1171 [400]
4	38 [13]	79 [27]	161 [55]	304 [104]	790 [270]	1525 [521]	2297 [785]
6	88 [30]	179 [61]	351 [120]	664 [227]	1703 [582]	3283 [1122]	4940 [1688]
8	161 [55]	325 [111]	632 [216]	1185 [405]	3035 [1037]	5838 [1995]	7916 [2705]
12	369 [126]	735 [251]	1428 [488]	2672 [913]	6833 [2335]	12563 [4293]	16932 [5786]
16	658 [225]	1314 [449]	2543 [869]	4138 [1414]	7781 [2659]	11884 [4061]	16019 [5474]
Reducer Ratio							
	15.86	19.58	24.06	29.32	39.61	48.95	56.83

Other Motions (stops and index periods) available. Contact your DESTACO sales representative for more information.

Features

- KH47 Reducer and AC Motor with Optional Brake
- Double Extended Camshaft (Input Shaft)
- Center Thru Hole (Ø130 mm [Ø5.1 in.])
- AC drive package with Inverter Duty Motor and Inverter Drive (up to 60 cpm)
- Cycle Cam and Limit Switch Mounted to Camshaft
- Right Hand Cam

Output Load Capacity (loads carried during index):

Radial	13789 N [3100 lbs]
Thrust/Axial	35586 N [8000 lbs]
Moment	3240 N-m [28674 in-lb]

Typical Application Dial Diameter:

508 mm [20 in] to 1524 mm [60 in]

Accuracy

±22 arcsec / ±0,08 mm [±.003in]
at 76 mm [30in] Radius

Repeatability

±5 arcsec / ±0,020 mm [±.0008in]
at 762 mm [30in] Radius

Optional Accessories

- 7300C Reducer (Ratios from 15:1 to 60:1)
- 1.5 HP DC motor
- Varipak DC Motor Control (up to 30 cpm)
- Output Mechanical Overload Clutch
– See Page 27
- EZ Mount Dial Adapter
- 7350C Heavy Duty Reducer (Ratios from 10:1 to 60:1)
- Stationary Center Post
- Dual Cam and Limit Switch
- Left Hand Cam
- Relief in Dwell for shot-pin applications

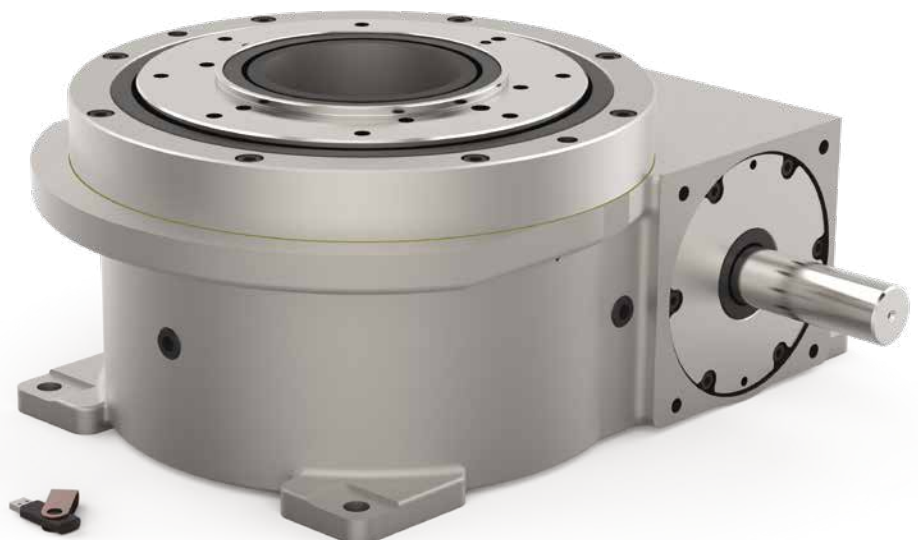

1100RDM SERIES

Rotary Index Drive | Dimensions

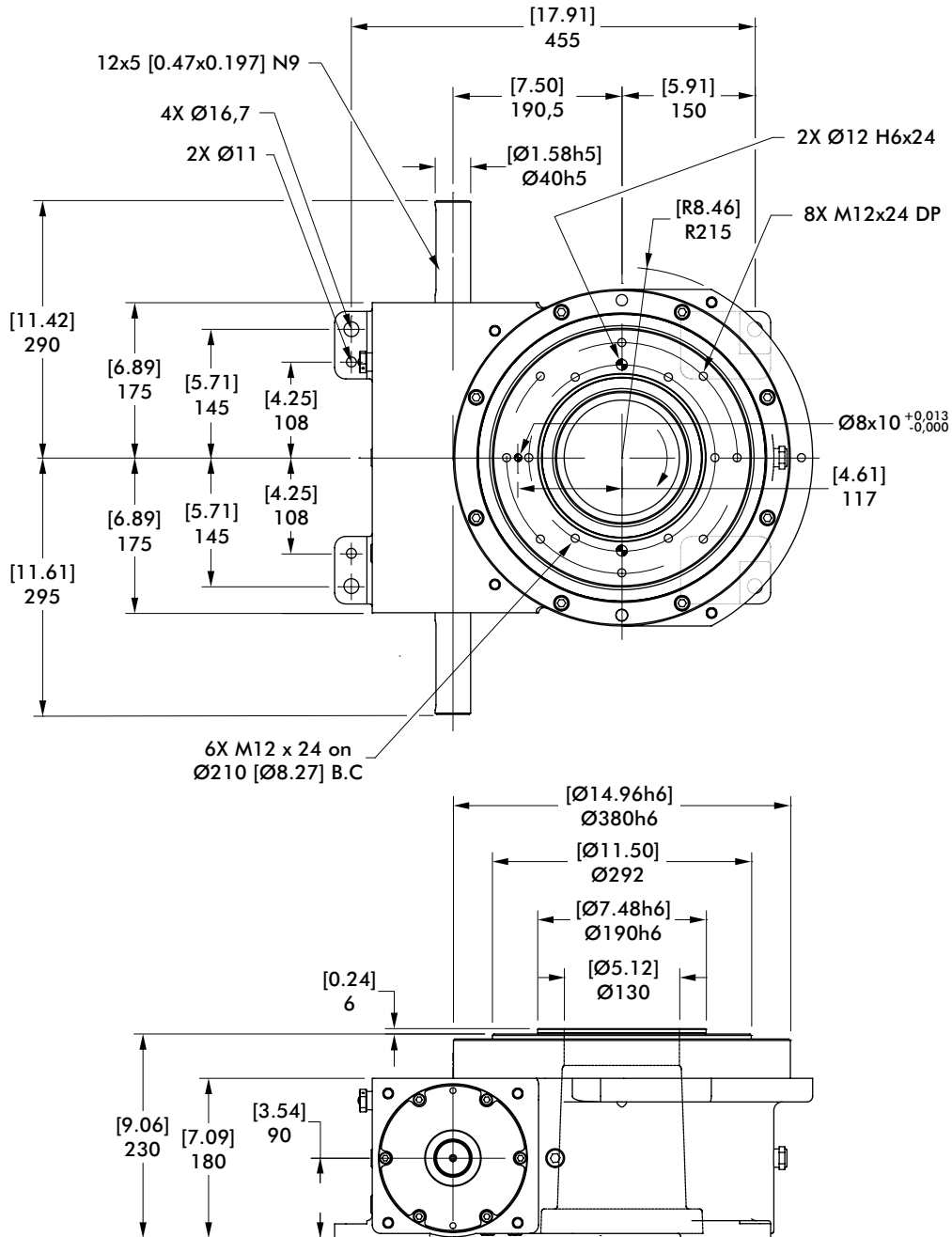

mm [INCH]

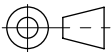

THIRD ANGLE PROJECTION

1100RDM SERIES

Rotary Index Drive | Product Overview | Technical Specifications

Center Post

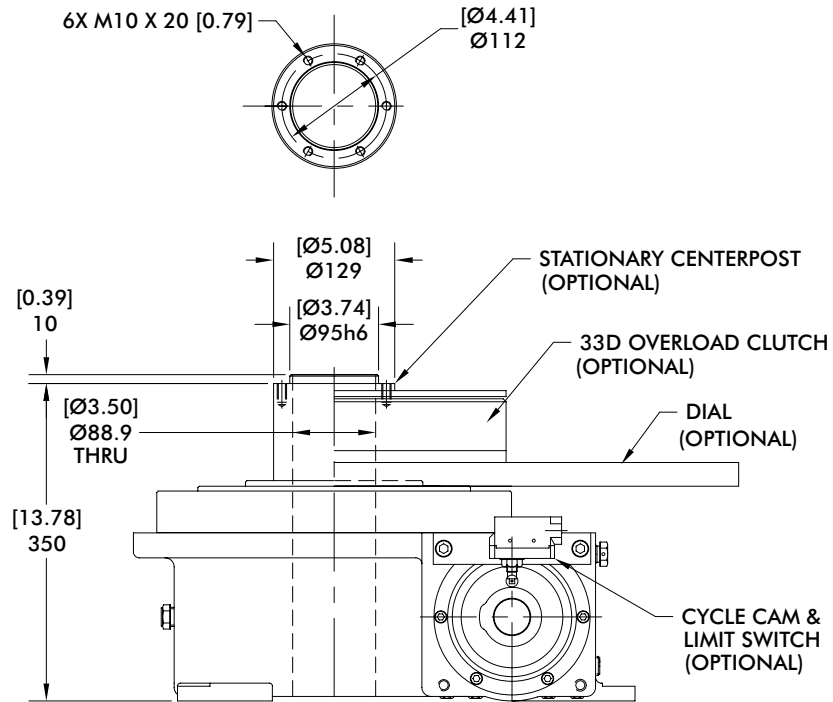

mm [INCH]

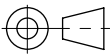

THIRD ANGLE PROJECTION

Proximity Switch

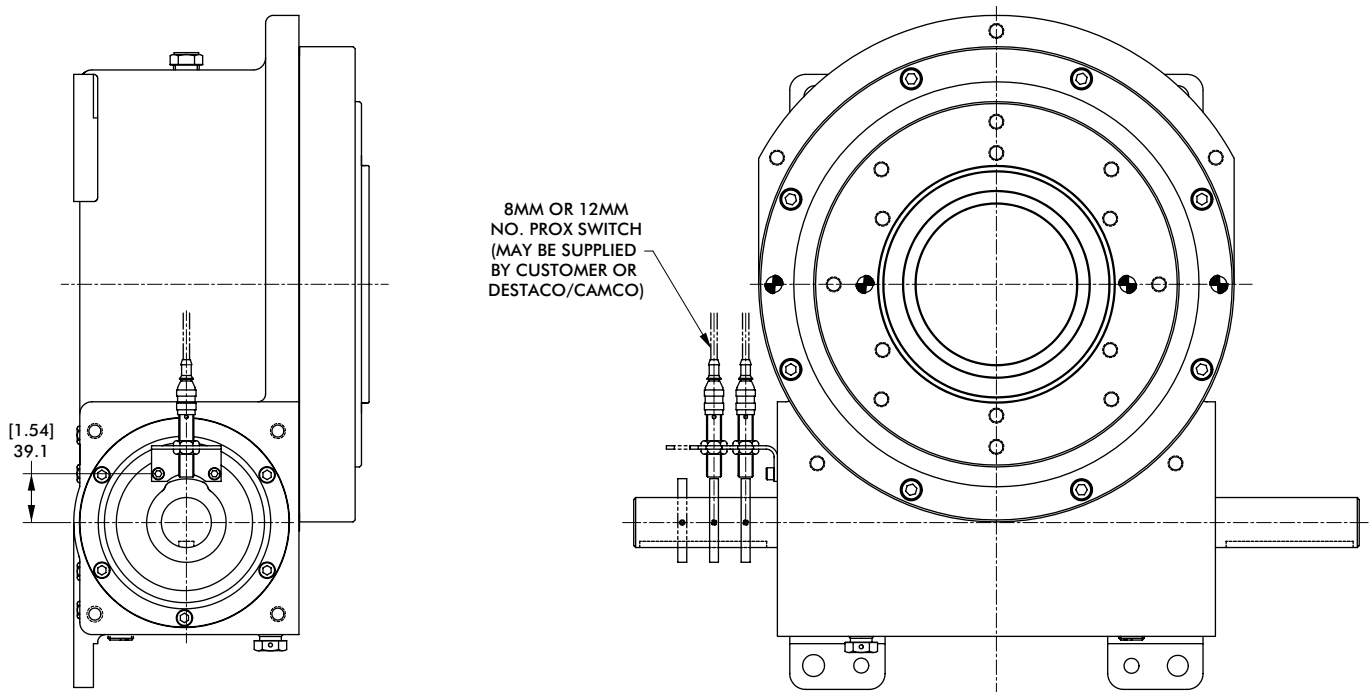

110ORDM SERIES

Rotary Index Drive | Dimensions

33D Overload Clutch

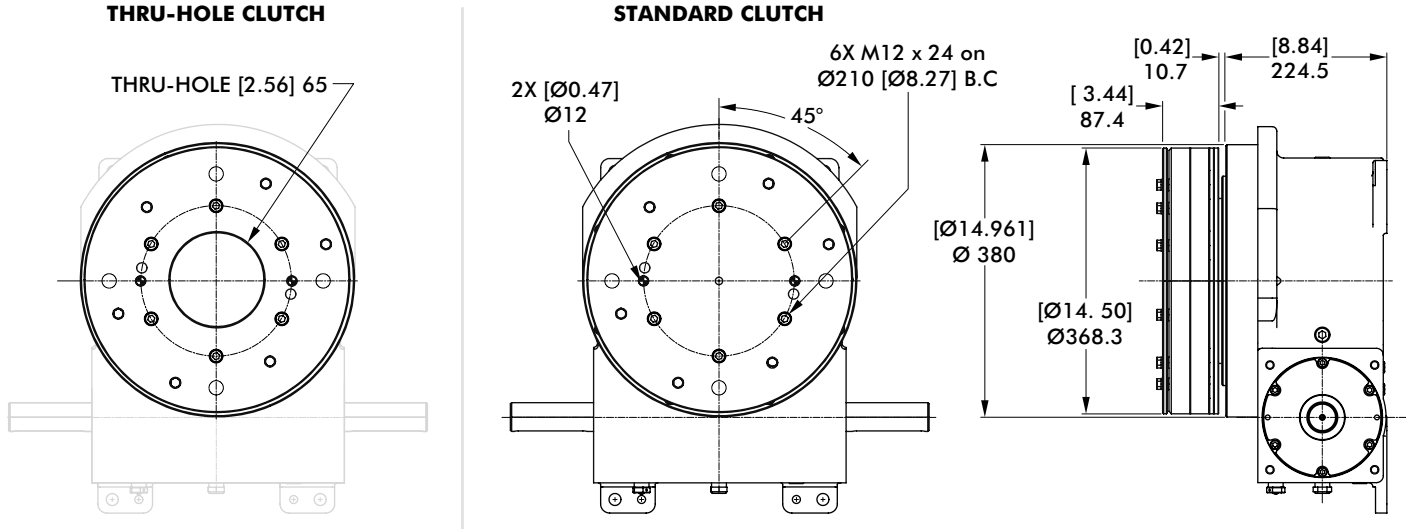

mm [INCH]



33D Overload Clutch with EZ Dial Mounting Adapter

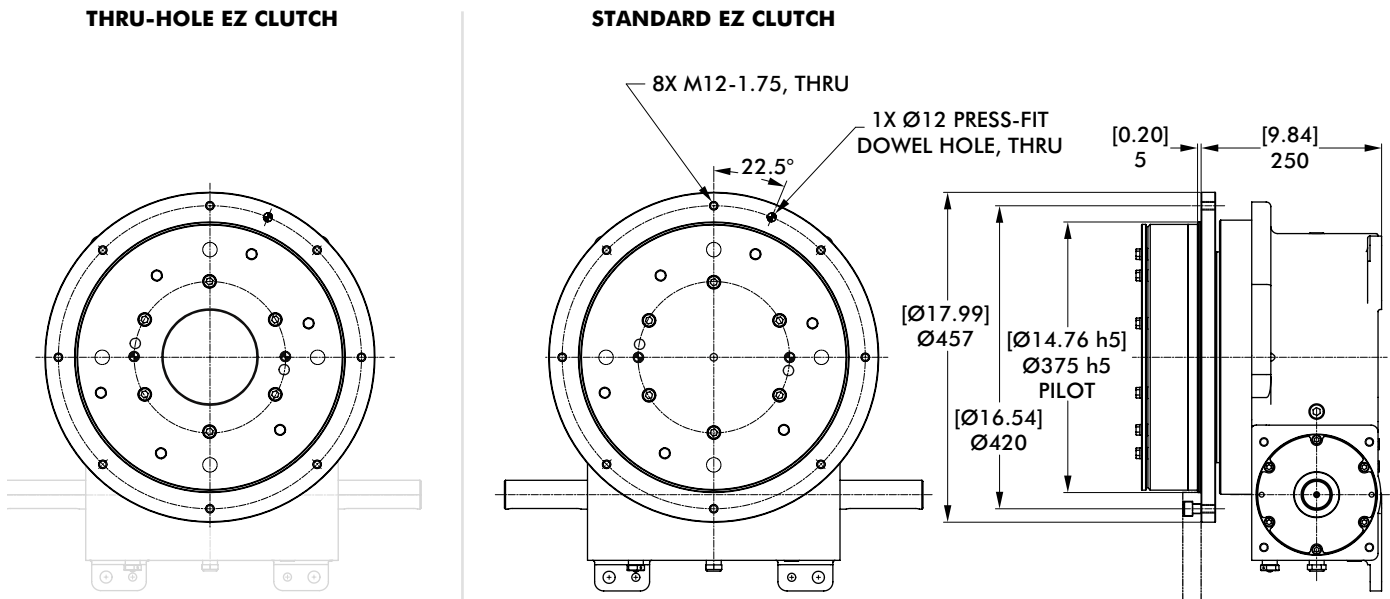

Model	Internal Inertia kg-m ² [lb-in ²]	Torque Setting N-m [in-lb]
33D	0,852 [2910]	960, 1469, 2260, 2881 [8500, 13000, 20000, 25500]

1100RDM SERIES

Notes

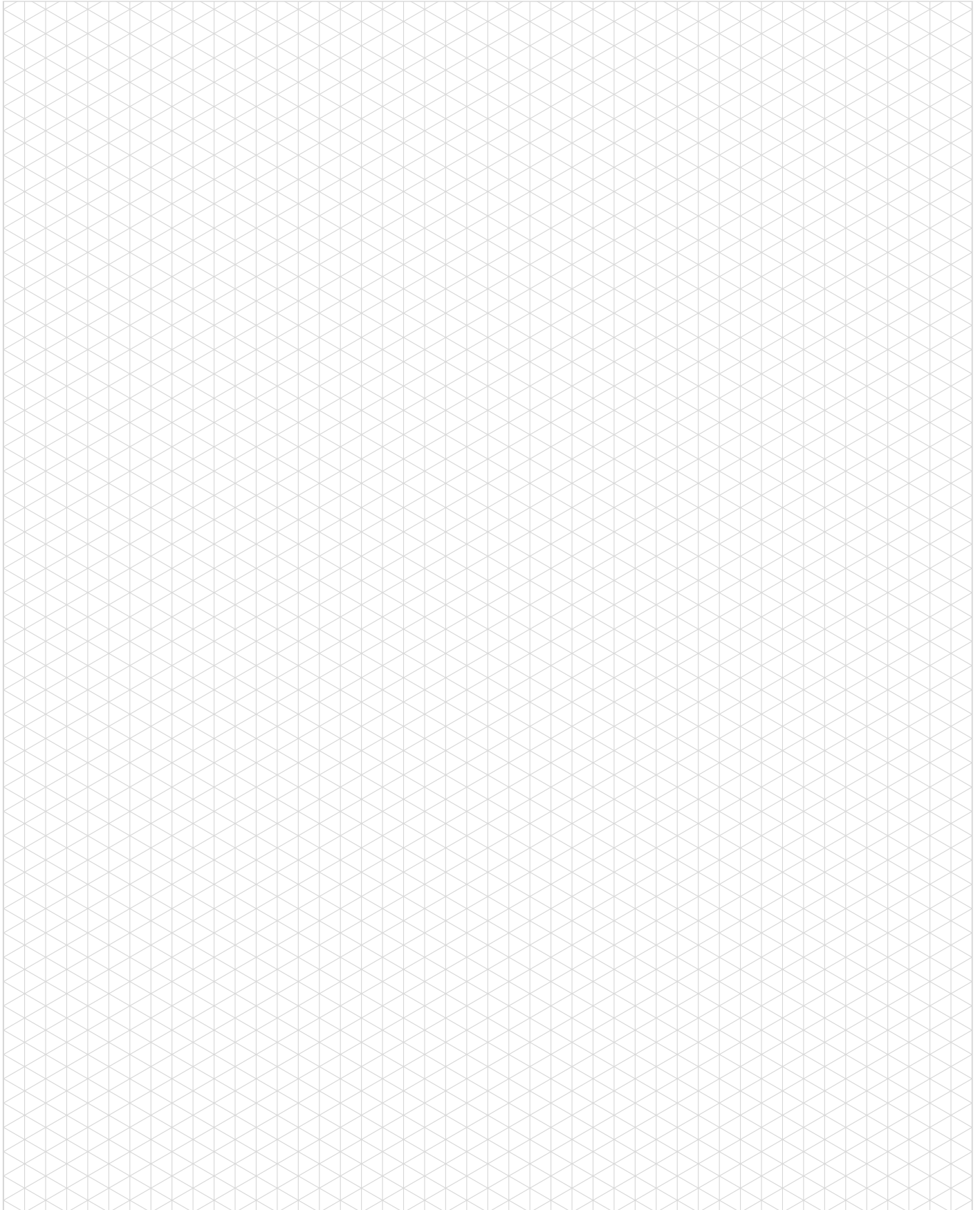

1305RDM SERIES

Rotary Index Drive | How To Order

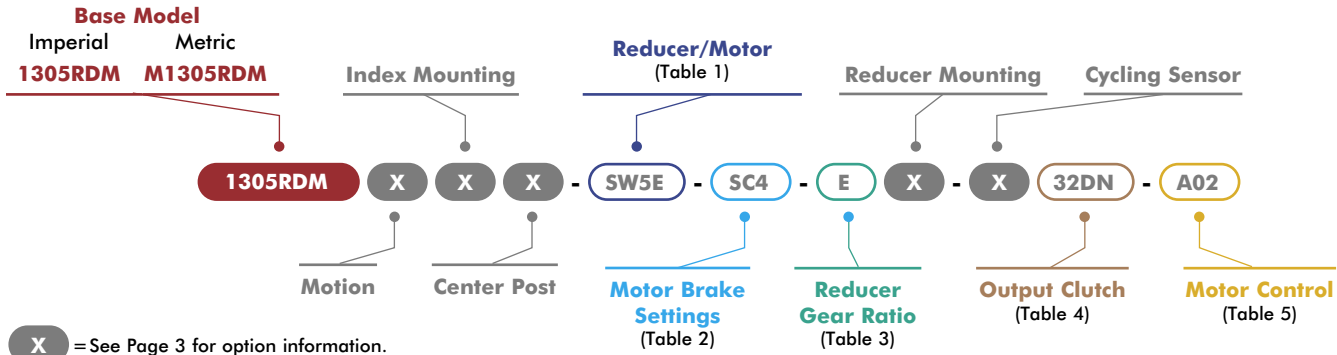

1 Reducer/Motor Options*

Code	Description
0000	No Reducer or Motor*
7350C Motors	
CD2A	Indexer with 7350C Adapter*
CS2B	CONE DRIVE 7350C W/56C Reducer, SE Worm
CS2C	CONE DRIVE 7350C W/145TC Reducer, SE Worm
CS2D	CONE DRIVE 7350C Reducer w/ 1.0HP AC 56C Motor, SE Worm
CS2E	CONE DRIVE 7350C Reducer w/ 2.0HP AC 145TC Motor, SE Worm
CS2F	CONE DRIVE 7350C Reducer w/ 1.0HP 90V DC 56C Motor, SE Worm
CS2G	CONE DRIVE 7350C Reducer w/1.0HP 180V DC 56C Motor, SE Worm
CS2H	CONE DRIVE 7350C Reducer w/2.0HP 180V DC 143TC Motor, SE Worm
CD2B	CONE DRIVE 7350C w/ 56C Reducer, DE Worm
CD2C	CONE DRIVE 7350C W/145TC Reducer, DE Worm
CD2D	CONE DRIVE 7350C Reducer w/ 1.0HP AC 56C Motor, DE Worm
CD2E	CONE DRIVE 7350C Reducer w/ 2.0HP AC 145TC Motor, DE Worm
CD2F	CONE DRIVE 7350C Reducer w/ 1.0HP 90V DC 56C Motor, DE Worm
CD2G	CONE DRIVE 7350C Reducer w/ 1.0HP 180V DC 56C Motor, DE Worm
CD2H	CONE DRIVE 7350C Reducer w/ 2.0HP 180V DC 143TC Motor, DE Worm
SEW KH67 Motors	
SW4A	Indexer with KH67 Adapter*
SW4B	SEW KH67DRN80M4 Reducer with 0.75Kw Motor (60Hz, 230/460V)
SW4C	SEW KH67DRN80M4 Reducer with 0.75Kw Motor (50Hz, 400V)
SW4D	SEW KH67DRN80M4 Reducer with 0.75Kw Motor (60Hz, 575V)
SW4E	SEW KH67DRN90L4 Reducer with 1.5Kw Motor (60Hz, 230/460V)
SW4F	SEW KH67DRN90L4 Reducer with 1.5Kw Motor (50Hz, 400V)
SW4G	SEW KH67DRN90L4 Reducer with 1.5Kw Motor (60Hz, 575V)
SEW KH77 Motors	
SW5A	Indexer with KH77 Adapter*
SW5B	SEW KH77DRN80M4 Reducer with 0.75Kw Motor (60Hz, 230/460V)
SW5C	SEW KH77DRN80M4 Reducer with 0.75Kw Motor (50Hz, 400V)
SW5D	SEW KH77DRN80M4 Reducer with 0.75Kw Motor (60Hz, 575V)
SW5E	SEW KH77DRN90L4 Reducer with 1.5Kw Motor (60Hz, 230/460V)
SW5F	SEW KH77DRN90L4 Reducer with 1.5Kw Motor (50Hz, 400V)
SW5G	SEW KH77DRN90L4 Reducer with 1.5Kw Motor (60Hz, 575V)
STM RMI-110 Motors	
RM7A	Indexer with RMI-110 Adapter*
RM7B	STM RMI-110/LFB/IEC90-B14 Reducer only
RM7C	STM RMI-110/LFB/IEC100-B14 Reducer only
RM7D	STM RMI-110/LFB/1.1kW Reducer and Motor
RM7E	STM RMI-110/LFB/2.2kW Reducer and Motor

*All Reducer/Motor adapters require Gear Ratio option to be 0.

2 Motor Brake* 3 Reducer Gear Ratios*

Code	Description	Code	Description			
000	(NO BRAKE/NO SEW)					
S1A	1.69 Nm (BE05)					
S1B	2.49 Nm (BE05)					
S1C	3.50 Nm (BE05)					
S2A	4.97 Nm (BE1)					
S2B	7.01 Nm (BE1)					
S2C	9.94 Nm (BE1)					
S3A	9.94 Nm (BE2)					
S3B	14.01 Nm (BE2)					
S3C	20.00 Nm (BE2)					
S4A	20.00 Nm (BE5)					
S4B	28.02 Nm (BE5)					
S4C	40.00 Nm (BE5)					
S4D	55.03 Nm (BE5)					

Code	7350C	SEW KH67	SEW KH77	STM RMI-110
0	N/A	N/A	N/A	N/A
A	10:1	9.66:1	9.56:1	10:1
B	15:1	15.19:1	15.84:1	15:1
C	20:1	19.30:1	20.25:1	20:1
D	28:1	30.22:1	29.27:1	25:1
E	40:1	38.39:1	40.04:1	30:1
F	49:1	48.77:1	51.18:1	40:1
G	56:1	60.66:1	58.34:1	50:1
H	70:1	68.95:1	73.99:1	60:1

*All Reducer/Motor adapters require Gear Ratio option to be 0.
Select Gear ratio column based on the reducer type selected.

*SEW Motor brake setting options only. All other motors use option code 000.

4 Output Clutch & Settings

1305RDM Imperial Clutch Models		M1305RDM Metric Clutch Models	
Code	Description	Code	Description
0000	No Output Overload Clutch	0000	No Output Overload Clutch
32DA	32D/8500 In-Lb, Standard*	M32DA	M32D/960 Nm, Standard*
32DB	32D/13000 In-Lb, Standard*	M32DB	M32D/1470 Nm, Standard*
32DC	32D/20000 In-Lb, Standard*	M32DC	M32D/2260 Nm, Standard*
32DD	32D/31000 In-Lb, Standard*	M32DD	M32D/3500 Nm, Standard*
32DE	32D/16500 In-Lb, Standard*	M32DE	M32D/1865 Nm, Standard*
32DF	32D/25500 In-Lb, Standard*	M32DF	M32D/2880 Nm, Standard*
32DG	32D/23500 In-Lb, Standard*	M32DG	M32D/2655 Nm, Standard*
32DH	32D/8500 In-Lb, Thru-Hole	M32DH	M32D/960 Nm, Thru-Hole
32DJ	32D/13000 In-Lb, Thru-Hole	M32DJ	M32D/1470 Nm, Thru-Hole
32DK	32D/20000 In-Lb, Thru-Hole	M32DK	M32D/2260 Nm, Thru-Hole
32DL	32D/31000 In-Lb, Thru-Hole	M32DL	M32D/3500 Nm, Thru-Hole
32DM	32D/16500 In-Lb, Thru-Hole	M32DM	M32D/1865 Nm, Thru-Hole
32DN	32D/25500 In-Lb, Thru-Hole	M32DN	M32D/2880 Nm, Thru-Hole
32DP	32D/23500 In-Lb, Thru-Hole	M32DP	M32D/2655 Nm, Thru-Hole
32EA	32D/8500 In-Lb, Standard, EZ*	M32EA	M32D/960 Nm, Standard, EZ*
32EB	32D/13000 In-Lb, Standard, EZ*	M32EB	M32D/1470 Nm, Standard, EZ*
32EC	32D/20000 In-Lb, Standard, EZ*	M32EC	M32D/2260 Nm, Standard, EZ*
32ED	32D/31000 In-Lb, Standard, EZ*	M32ED	M32D/3500 Nm, Standard, EZ*
32EE	32D/16500 In-Lb, Standard, EZ*	M32EE	M32D/1865 Nm, Standard, EZ*
32EF	32D/25500 In-Lb, Standard, EZ*	M32EF	M32D/2880 Nm, Standard, EZ*
32EG	32D/23500 In-Lb, Standard, EZ*	M32EG	M32D/2655 Nm, Standard, EZ*
32EH	32D/8500 In-Lb, Thru-Hole, EZ	M32EH	M32D/960 Nm, Thru-Hole, EZ
32EJ	32D/13000 In-Lb, Thru-Hole, EZ	M32EJ	M32D/1470 Nm, Thru-Hole, EZ
32EK	32D/20000 In-Lb, Thru-Hole, EZ	M32EK	M32D/2260 Nm, Thru-Hole, EZ
32EL	32D/31000 In-Lb, Thru-Hole, EZ	M32EL	M32D/3500 Nm, Thru-Hole, EZ
32EM	32D/16500 In-Lb, Thru-Hole, EZ	M32EM	M32D/1865 Nm, Thru-Hole, EZ
32EN	32D/25500 In-Lb, Thru-Hole, EZ	M32EN	M32D/2880 Nm, Thru-Hole, EZ
32EP	32D/23500 In-Lb, Thru-Hole, EZ	M32EP	M32D/2655 Nm, Thru-Hole, EZ

* Cannot be used with center post options P and B.

5 Motor Control

Code	Description
000	NO MOTOR CONTROL
A01	120V 1Ph
A02	(AC) PowerFlex 523 1HP 240V 1Ph
A03	480V 3Ph
A04	120V 1Ph
A05	(AC) PowerFlex 525 1HP 240V 1Ph
A06	480V 3Ph
A07	240V 3Ph
A08	(AC) PowerFlex 523 2HP 480V 3Ph
A09	240V 3Ph
A10	(AC) PowerFlex 525 2HP 480V 3Ph
A11	240V 3Ph
A12	(AC) PowerFlex 523 3HP 480V 3Ph
A13	240V 1Ph
A14	(AC) PowerFlex 525 3HP 480V 3Ph
A15	480V 3Ph
A16	(AC) PowerFlex 523 5HP 600V 3Ph
A17	480V 3Ph
A18	(AC) PowerFlex 525 5HP 600V 3Ph
D01	Uni-Directional
D02	(DC) Varipak 1HP 90VDC Bi-Directional
D03	Uni-Directional
D04	(DC) Varipak 2HP 180VDC Bi-Directional
D05	(DC) Cycletrol 3HP 180VDC

Maximum Inertia x 1000 kg-cm ² [lb-in ²] for standard package							
Stops	Motion Time [seconds]						
	0.458	0.611	0.764	0.917	1.222	1.528	1.833
2	0 [0]	12 [4]	38 [13]	76 [26]	140 [48]	214 [73]	298 [102]
3	6 [2]	32 [11]	76 [26]	146 [50]	258 [88]	389 [133]	538 [184]
4	29 [10]	94 [32]	208 [71]	380 [130]	664 [227]	995 [340]	1367 [467]
6	73 [25]	211 [72]	451 [154]	822 [281]	1419 [485]	2119 [724]	2909 [994]
8	138 [47]	383 [131]	811 [277]	1469 [502]	2528 [864]	3775 [1290]	5180 [1770]
12	325 [111]	878 [300]	1841 [629]	3319 [1134]	5706 [1950]	8510 [2908]	11670 [3988]
16	585 [200]	1571 [537]	3280 [1121]	5908 [2019]	10155 [3470]	15138 [5173]	20754 [7092]
Reducer Ratio							
	15	20	25	30	40	50	60

Other Motions (stops and index periods) available. Contact your DESTACO sales representative for more information.

Features

- 7300C Reducer (Ratios from 15:1 to 60:1)
- Double Extended Camshaft (Input Shaft)
- Center Thru Hole (Ø127 mm [Ø5.00 in.])
- 2 HP AC Drive Package with Inverter Duty Motor and Inverter Drive (up to 60 cpm)
- Cycle Cam and Limit Switch Mounted to Camshaft
- Right Hand Cam

Output Load Capacity (loads carried during index):

Radial	20684 N [4650 lbs]
Thrust/Axial	51822 N [11650 lbs]
Moment	4579 N-m [40528 in-lb]

Typical Application Dial Diameter:

508 mm [20 in] to 1829 mm [72 in]

Accuracy

±38 arcsec / ±0,18 mm [±.007in]
at 914,4 mm [36in] Radius

Repeatability

±10 arcsec / ±0,05 mm [±.002in]
at 914,4 mm [36in] Radius

Optional Accessories

- 2 hp DC Motor
- Varipak DC Motor Control (up to 30 cpm)
- 7350C Heavy Duty Reducer (Ratios from 10:1 to 60:1)
- Output Mechanical Overload Clutch
– See Page 33
- EZ Mount Dial Adapter
- Stationary Center Post
- Dual Cam and Limit Switch
- Base Riser Blocks
- Electric Clutch-Brake
- Left Hand Cam
- Relief in Dwell for shot-pin applications

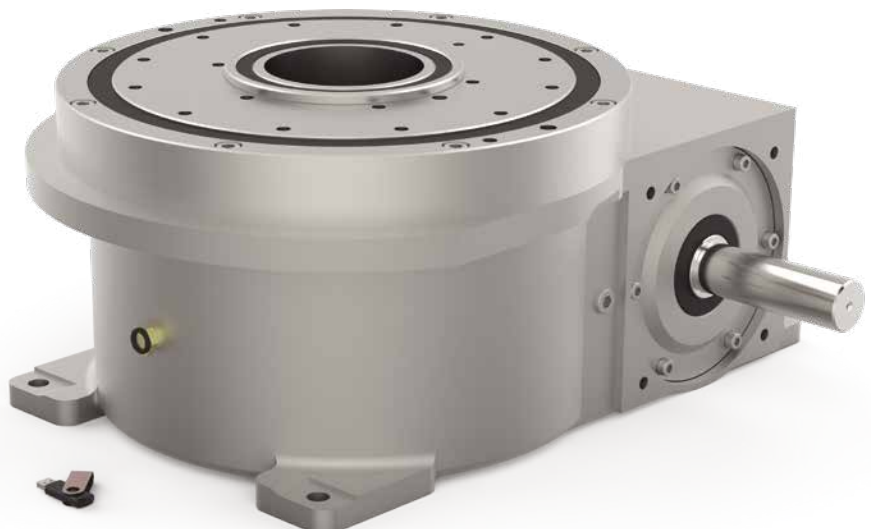

1305RDM SERIES

Rotary Index Drive | Product Overview | Technical Specifications

Center Post

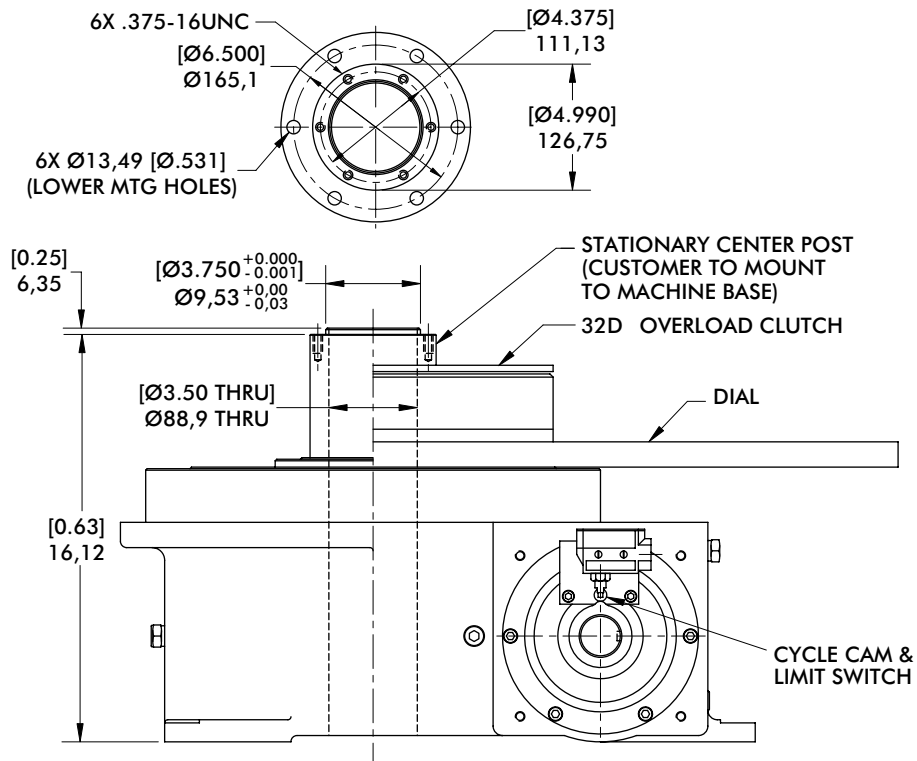

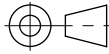
mm [INCH]

 THIRD ANGLE
 PROJECTION

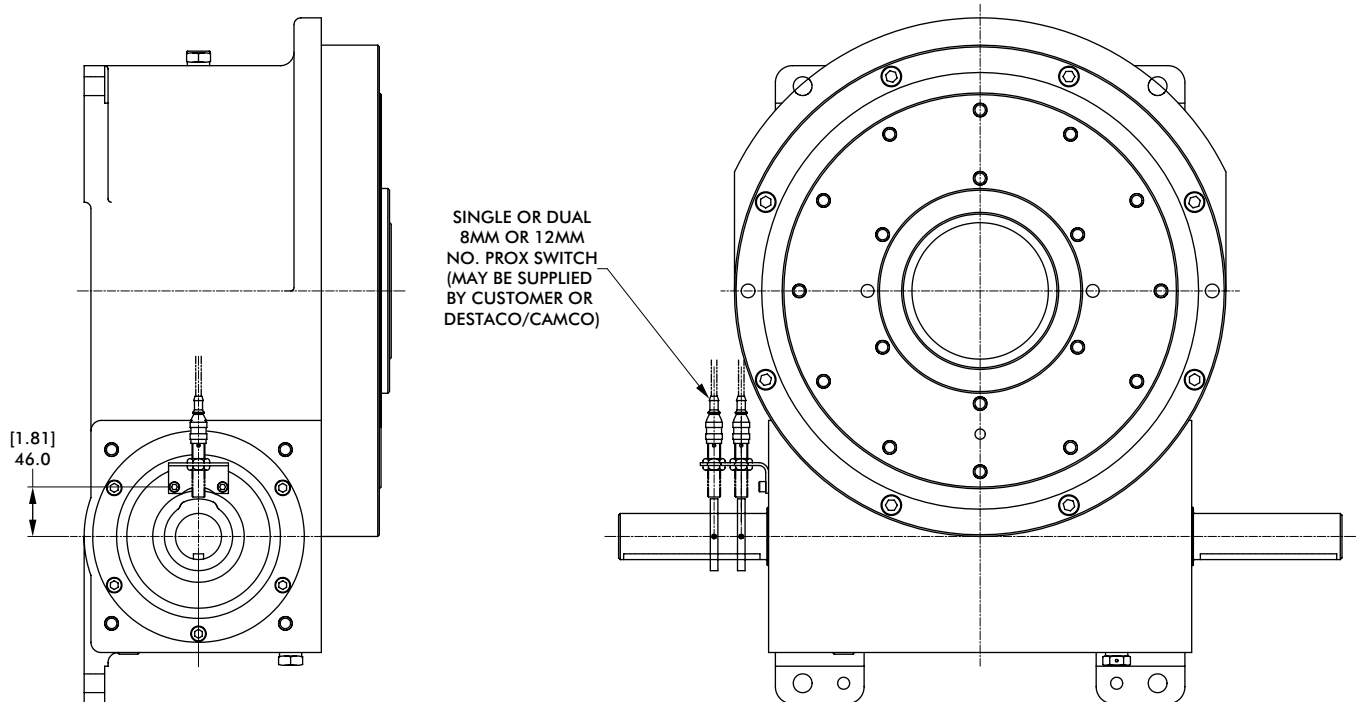
Proximity Switch



1305RDM SERIES

Rotary Index Drive | Dimensions

32D Overload Clutch

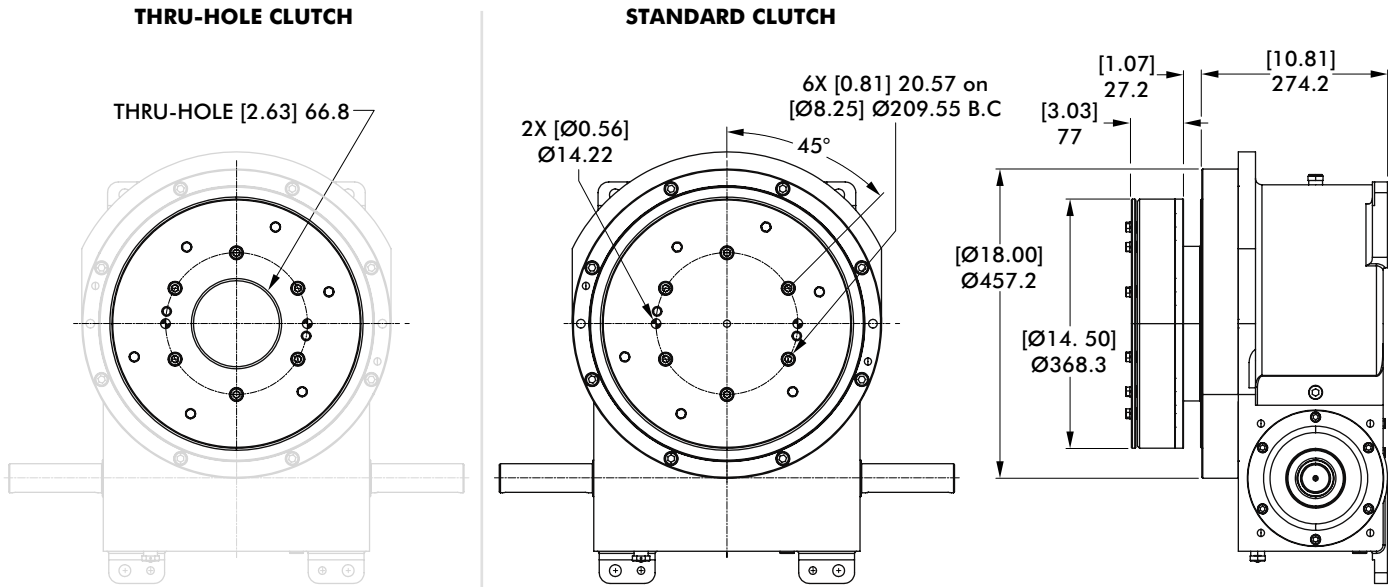

32D Overload Clutch with EZ Dial Mounting Adapter

mm [INCH]

THIRD ANGLE PROJECTION

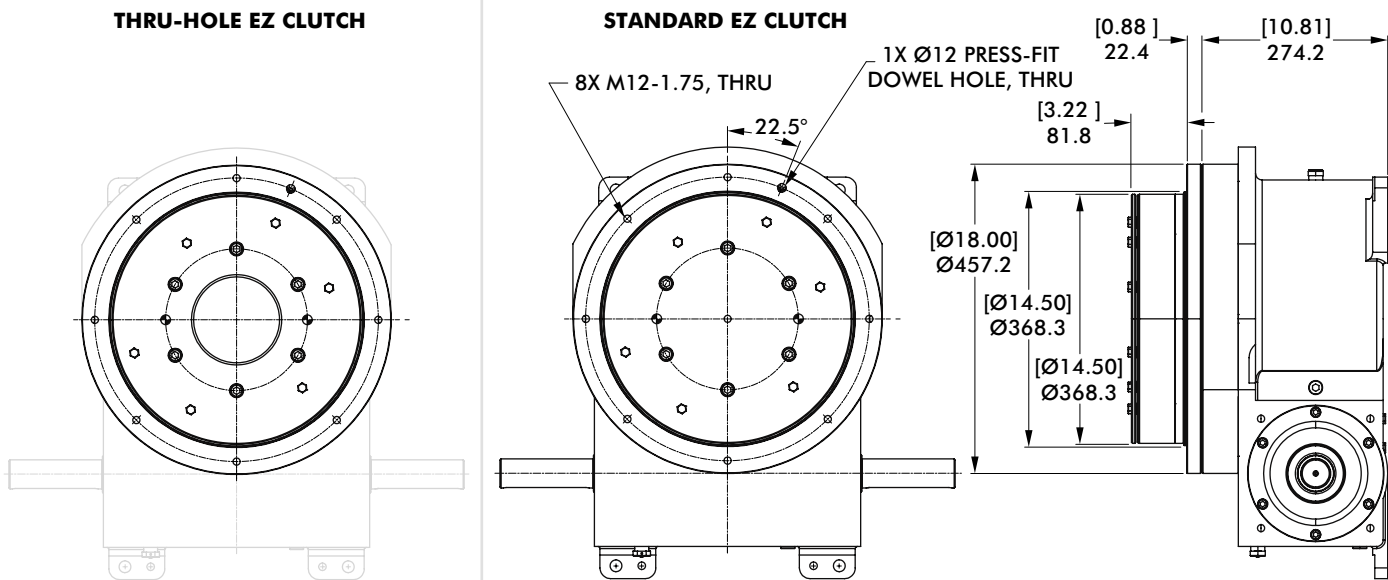

Model	Internal Inertia kg-m ² [lb-in ²]	Torque Setting N-m [in-lb]
32D	0,852 [2910]	960, 1469, 2260, 3503 [8500, 13000, 20000, 31000]

1305RDM SERIES

Notes

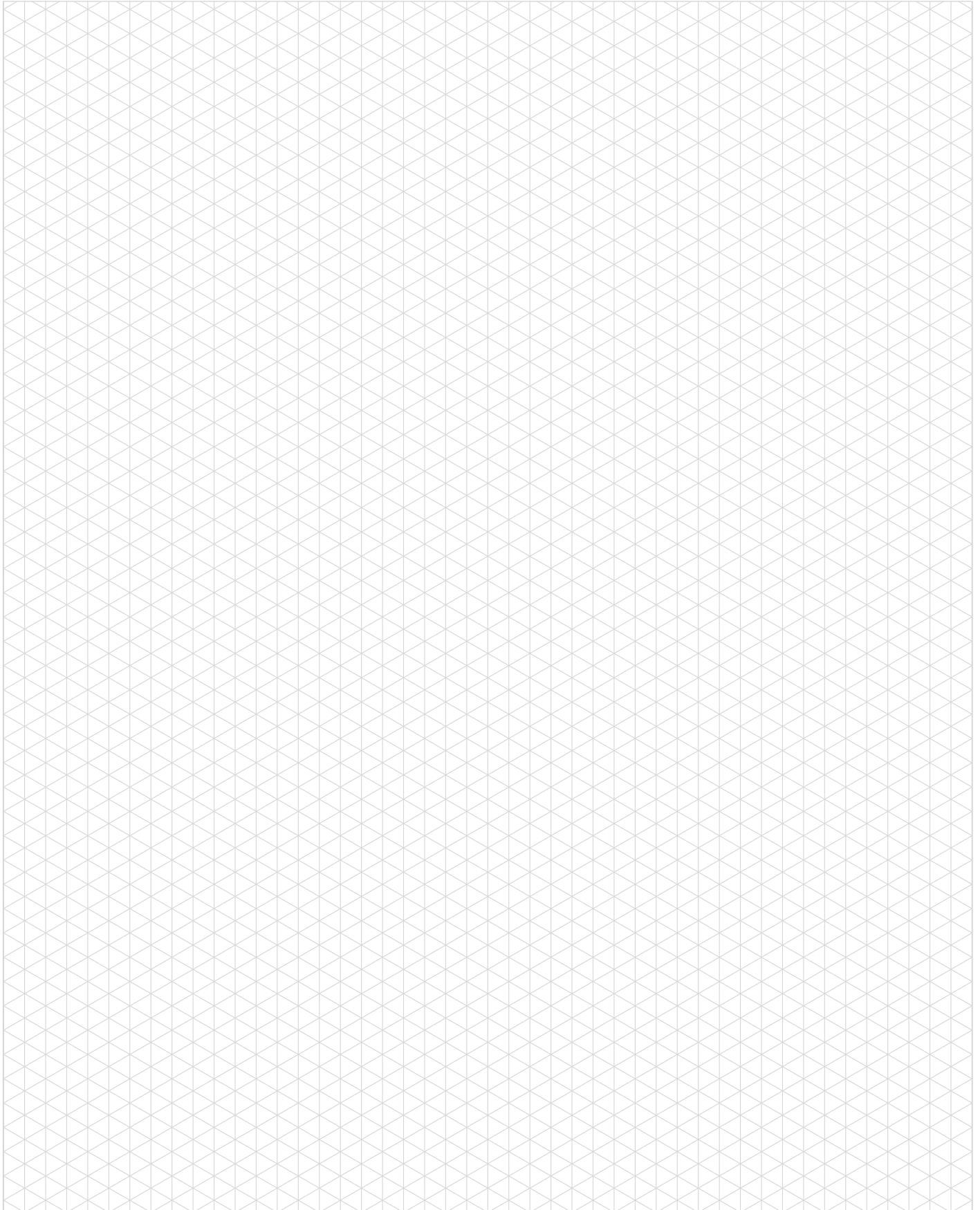

Maximum Inertia x 1000 kg-cm ² [lb-in ²] for standard package							
Stops	Motion Time [seconds]						
	0.458	0.611	0.764	0.917	1.222	1.528	1.833
2	0 [0]	0 [0]	23 [8]	79 [27]	266 [91]	533 [182]	749 [256]
3	0 [0]	32 [11]	120 [41]	255 [87]	720 [246]	1381 [472]	1917 [655]
4	3 [1]	91 [31]	249 [85]	495 [169]	1332 [455]	2523 [862]	3488 [1192]
6	56 [19]	243 [83]	577 [197]	1097 [375]	2871 [981]	5390 [1842]	7439 [2542]
8	132 [45]	462 [158]	1056 [361]	1984 [678]	5133 [1754]	9616 [3286]	13257 [4530]
12	351 [120]	1100 [376]	2435 [832]	4518 [1544]	11606 [3966]	21690 [7412]	29881 [10211]
16	656 [224]	1987 [679]	4360 [1490]	8065 [2756]	20666 [7062]	38593 [13188]	53152 [18163]
Reducer Ratio							
	15	20	25	30	40	50	60

Other Motions (stops and index periods) available. Contact your DESTACO sales representative for more information.

Features

- 7400C Reducer (Ratios from 15:1 to 60:1)
- Double Extended Camshaft (Input Shaft)
- Center Thru Hole (Ø165,1 mm [Ø6.50 in.])
- 2 or 3 HP AC Drive Package with Inverter Duty Motor and Inverter Drive (up to 60 cpm)
- Cycle Cam and Limit Switch Mounted to Camshaft
- Right Hand Cam

Output Load Capacity (loads carried during index):

Radial	26022 N [5850 lbs]
Thrust/Axial	61166 N [14650 lbs]
Moment	7696 N-m [68119 in-lb]

Typical Application Dial Diameter:

660 mm [26 in] to 1829 mm [96 in]

Accuracy

±27 arcsec / ±0,15 mm [±.006in]
at 1219,2 mm [48in] Radius

Repeatability

±7 arcsec / ±0,041 mm [±.0016in]
at 1219,2 mm [48in] Radius

Optional Accessories

- 2 hp DC Motor with Varipak DC Motor Control (up to 30 cpm)
- 3 hp DC Motor
- 7500C Heavy Duty Reducer (Ratios from 10:1 to 60:1)
- Output Mechanical Overload Clutch – See Page 39
- EZ Mount Dial Adapter
- Stationary Center Post
- Dual Cam and Limit Switch
- Base Riser Blocks
- Electric Clutch-Brake
- Left Hand Cam
- Relief in Dwell for shot-pin applications



1800RDM SERIES

Rotary Index Drive | Product Overview | Technical Specifications

Center Post

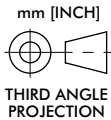
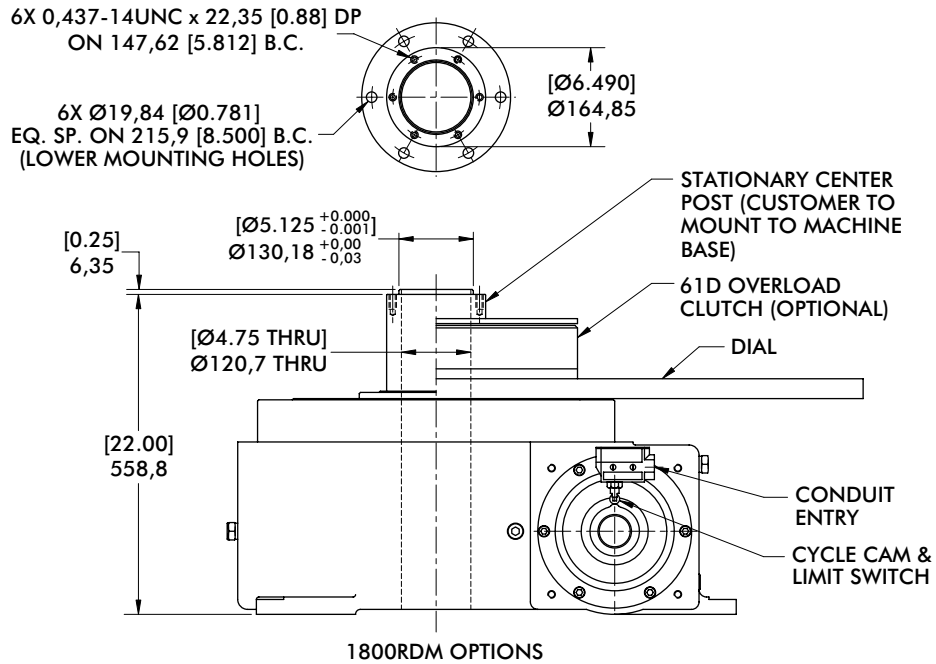

Proximity Switch

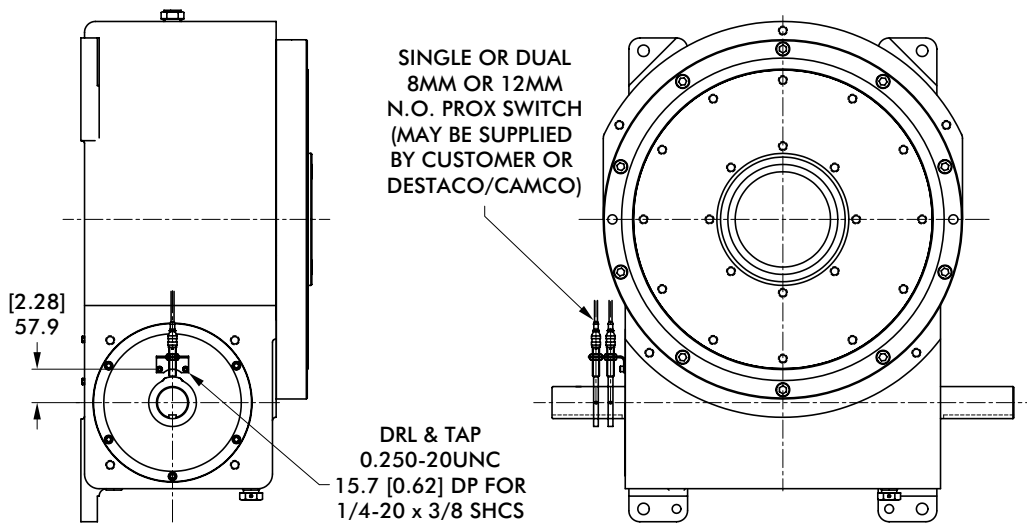

180ORDM SERIES

Rotary Index Drive | Dimensions

61D Overload Clutch

THRU-HOLE CLUTCH

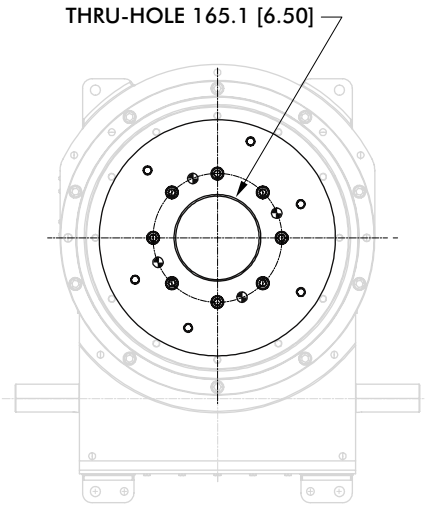

STANDARD CLUTCH

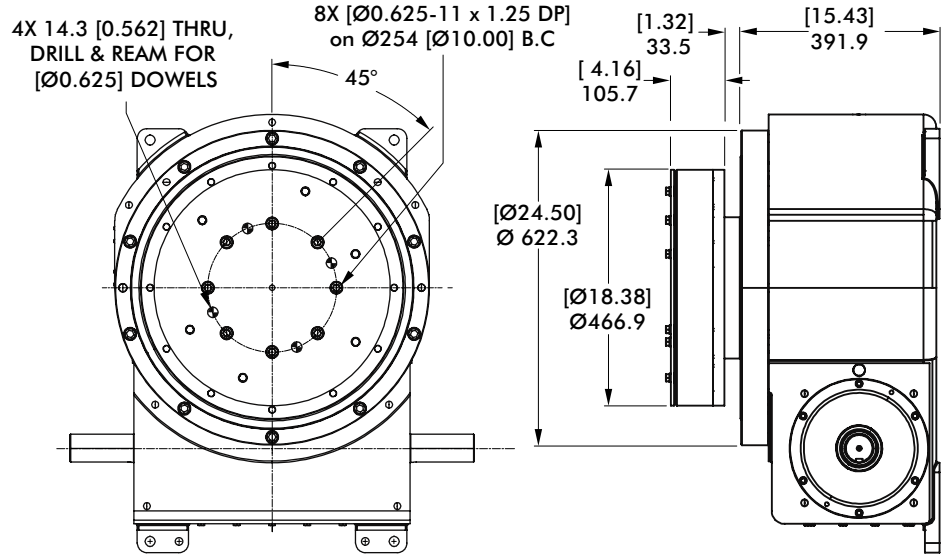

mm [INCH]

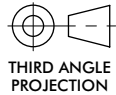

61D Overload Clutch with EZ Dial Mounting Adapter

THRU-HOLE EZ CLUTCH

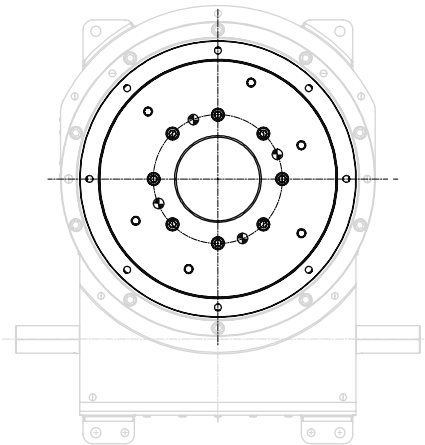

STANDARD EZ CLUTCH

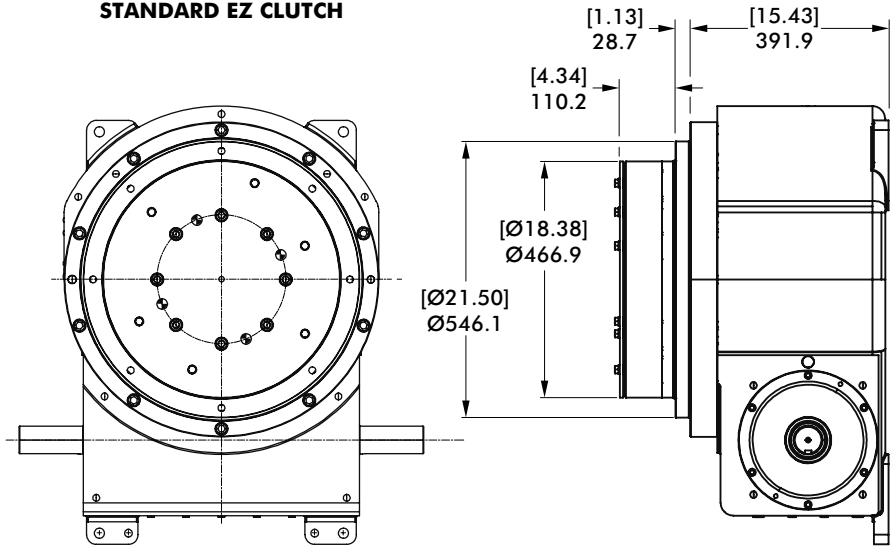

Model	Internal Inertia kg-m ² [lb-in ²]	Torque Setting N-m [in-lb]
61D	1,434 [4900]	2599, 4067, 4971, 5649, 6779 [23000, 36000, 44000, 50000, 60000]

1800RDM SERIES

Notes

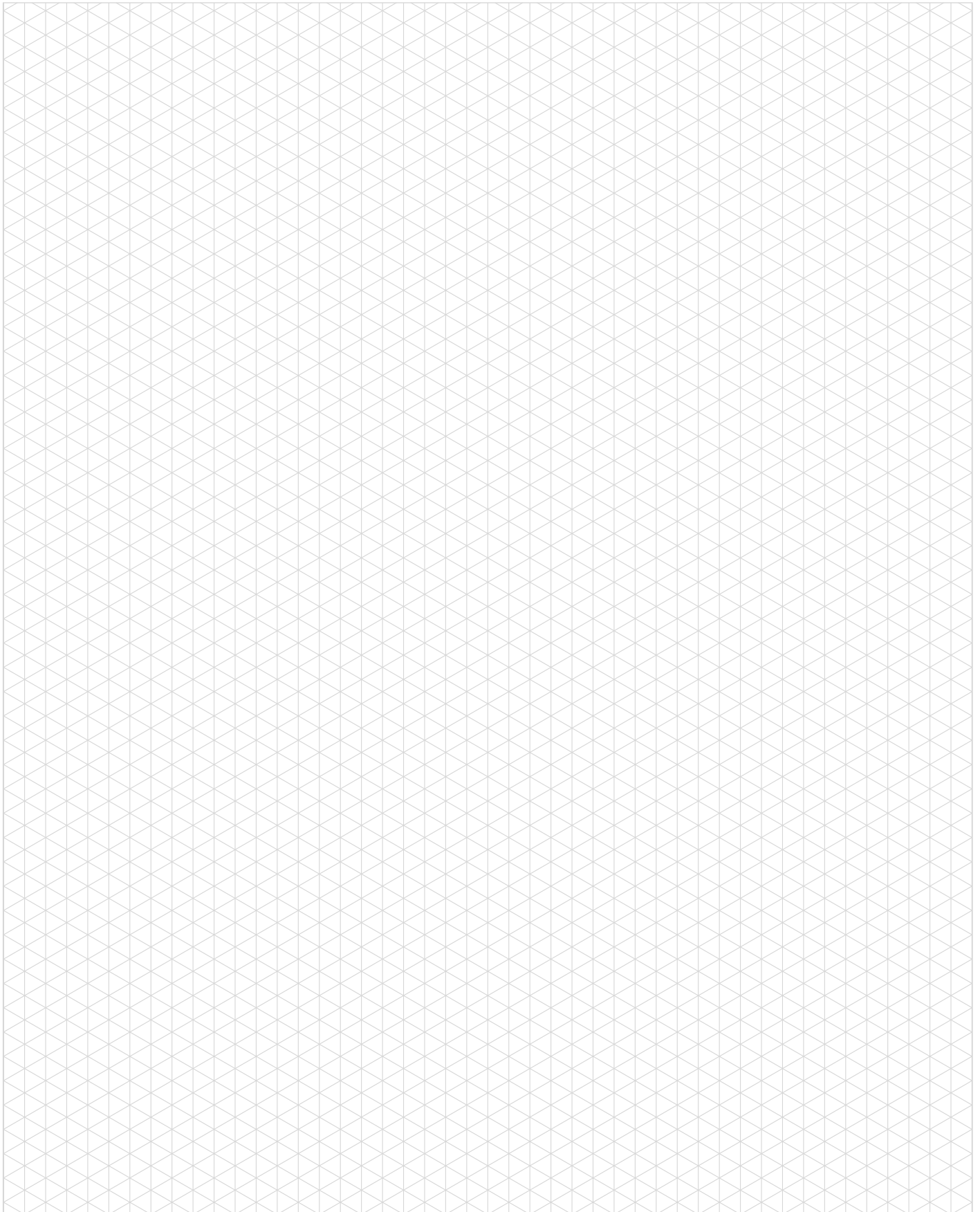

SIZING AND APPLICATION CHART

Tool Changers

Manual Tool Changer

See Page TC-TC1-1



Specifications:	TC1	
Max. Payload:	Kg [lb]	10 [22]
Coupled Weight:	Kg [lb]	0.33 [0.73]
Max Moment (My, Mz, Mx)	Nm [in-lb]	100 [885]
Max Force (Fy, Fz)	N [lbf]	1000 [225]
Max Force (Fx)	N [lbf]	100 [22.5]

Automatic Tool Changers

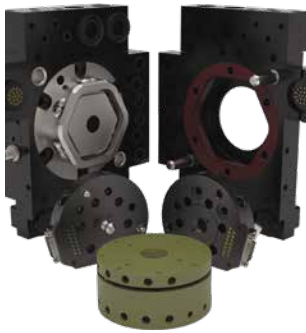

Series	Page-TC-#	Max Moment Kg [lb]		Max Payload Kg [lb]		Weight Kg [lb]		Features																		
		0 to 50 [0 to 110]	50 to 100 [110 to 220]	100 to 500 [220 to 1100]	500 to 1000 [1100 to 2200]	1000 to 2000 [2200 to 4400]	2000 to 3000 [4400 to 6600]	3000 to 4000 [6600 to 8800]	4000+ [9120+]	0 to 50 [0 to 110]	50 to 100 [110 to 220]	100 to 500 [220 to 1100]	500 to 1000 [1100 to 2200]	1000+ [2280+]	0 to 2 [0 to 4.4]	2 to 4 [4.4 to 8.8]	4 to 6 [8.8 to 13.2]	6 to 8 [13.2 to 17.6]	8+ [17.6+]	Optional Modules	High Temperature	Round Design	Rectangular Design	Fail-safe Locking		
RQC/RTP-200	RQTP-3			●																	✓		✓	✓		
RQC/RTP-400	RQTP-7				●																✓		✓	✓		
RQC/RTP-800	RQTP-7					●															✓		✓	✓		
RQC/RTP-1200	RQTP-7						●														✓		✓	✓		
RQC/RTP-2400	RQTP-13							●													✓		✓	✓		
QC/TP-30	QCTP-5	●							●													✓		✓		
QC/TP-60	QCTP-7		●						●												✓		✓	✓		
QC/TP-60-10	QCTP-9		●						●													✓		✓	✓	
QC/TP-150	QCTP-11			●					●												✓		✓	✓		
RHC-1	RHC-3	●							●													✓	✓	✓		
RHC-2	RHC-5		●						●													✓	✓	✓		
RHC-3	RHC-7				●				●													✓	✓	✓		
RHC-4	RHC-9					●			●													✓	✓	✓		

Technical Information

Pneumatic Specification

Pressure Range (Locked Cylinder):

3~7 bar [40~100 psi] (QC/TP, RHC Series)

4~7 bar [60~100 psi] (RQC/RTP Series)

Cylinder Type: Double Acting, Spring Assist

Valve Required to Actuate:

3-way, 2-position (QC-30 only)

4-way, 2-Position

Air Quality Requirements

Air Filtration: 40 Microns or Better

Air Lubrication: Not Necessary*

Air Humidity: Low Moisture Content (Dry)

(*Addition of lubrication will greatly increase service life.

Temperature Operating Range

Buna-N-Seals: -35°~80° C [-30°~180° F] (All Models)

Viton® Seals: -30°~150° C [-20°~300° F] (RHC Series)

Maintenance Specification

Expected Life: Normal Application: 5 Million Cycles

With Preventative Maintenance: 10+ Million Cycles

Repeatability: ±0.025mm [±0.001 in]

Field Repairable: Yes

Seal Repair Kits Available: Yes

Application Restrictions

- Dirty or Gritty Environments
- Machining Operations Generating Chips
- Environments with Loose Particulates

SIZING AND APPLICATION CHART

Cylindrical Horizontal Compliance Device



Series	Page-TC-#	Max Centering Force Kg [lb]					Max Payload Kg [lb]			Weight Kg [lb]		Misalignment ±mm [±in]		Features										
		0 to 500 [0 to 1100]	500 to 1000 [1100 to 2200]	1000 to 2000 [2200 to 4400]	2000 to 3000 [4400 to 6600]	3000 to 4000 [6600 to 8800]	4000+ [9120+]	0 to 5 [0 to 110]	5 to 10 [110 to 220]	10 to 20 [220 to 1100]	20 to 40 [1100 to 2200]	0 to 1 [0 to 4.4]	1 to 2 [4.4 to 8.8]	2 to 4 [8.8 to 13.2]	4+ [17.6+]	3 [0.12]	5 [0.20]	6.5 [0.25]	8 [0.31]	12 [0.47]	Custom Misalignment	Optional Spring Assist	Harsh Environments	Field Repairable
	CH-50-P	CH-3	●				●			●				●							✓	✓	✓	✓
	CH-80-P	CH-4		●				●		●					●						✓	✓	✓	✓
	CH-110-P	CH-5			●				●			●					●				✓	✓	✓	✓
	CH-140-P	CH-6				●			●			●		●			●				✓	✓	✓	✓
	CH-165-P	CH-7					●			●		●		●			●				✓	✓	✓	✓

Technical Information

Pneumatic Specification

Pressure Range (w/o springs): 2-7 bar [30-100 psi]
 Pressure Range (w/springs CH-50): 3-7 bar [43-100 psi]
 Pressure Range (w/springs): 4-7 bar [60-100 psi]
 Cylinder Type: Double Acting, Double Acting Spring Assist, or Single Acting Spring Return
 Dynamic Seals: Internally Lubricated Buna-N
 Valve Required to Actuate: Double Acting: 4-way, 2-Position; Single Acting (-RL or -RA Option): 3-way, 2-Position

Air Quality Requirements

Air Filtration: 40 Microns or Better
 Air Lubrication: Not Necessary*
 Air Humidity: Low Moisture Content (Dry)
 (*)Addition of lubrication will greatly increase service life.

Temperature Operating Range

Buna-N-Seals (Standard): -25°~80° C [-10°~180° F]

Maintenance Specification

Expected Life: Normal Application: 5 Million Cycles
 With Preventative Maintenance: 6+ Million Cycles
 Field Repairable: Yes
 Seal Repair Kits Available: Yes

ROBOTIC TOOLING SOLUTIONS

Automatic Tool Changer Sizing Guide

For tool changer sizing, the maximum effective moment during displacement will be considered. The effective moment will be calculate in the worst case of the application, and must consider:

- The weight of the tool
- The position of the center of gravity
- The dynamic effect due to the maximum acceleration or deceleration. (Emergency stop for example)

See below the simplified calculation formula to estimate the effective moment of your application.

Required Information		
M	Mass of the tool attached on the tool changer	Kg
L	Distance from the payload center of gravity to the tool changer	m
α	Maximum acceleration or deceleration of the robot	g

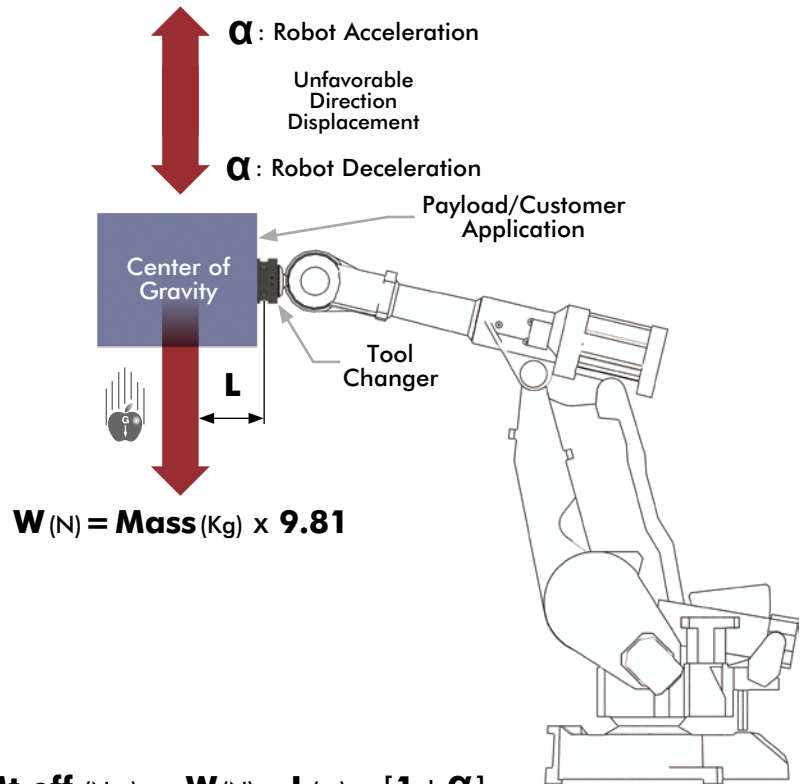

Effective Moment → $Mt\ eff\ (Nm) = W\ (N) \times L\ (m) \times [1 + \alpha]$

CAUTION: Applications with high and wide loads: in case of heavy application, we strongly recommend to strengthen the cylindrical and diamond indexing pins, between tool changer and tool plate, by adding larger diameter pins, the farthest to the center of changer tool, incorporated into the design of the tooling.

Application Example

Application Data	
Mass of tool	90 kg
Center of gravity / Tool Changer	0.5 m
Acceleration (or deceleration) of displacement	2 g

$$Mt\ eff = (90 \times 9.81) \times 0.5 \times (1 + 2)$$

$$Mt\ eff = 883 \times 0.5 \times 3$$

$$Mt\ eff = 1324.5\ Nm$$

Loading Capacity:

Max. Tensile **T**: 2670 N [600 lb]

Max. Compressive **C**: 3560 N [800 lb]

Max. Moment (**M_x/M_y/M_z**) 1580 Nm [14000 in-lb]

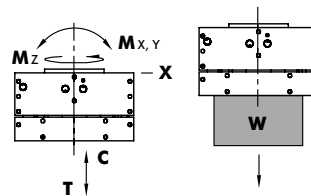

The obtained value 1324.5 Nm should be compared to the technical data of our products in this catalog in the "loading capacity information" section. For this application, the choice will be a RQC-400M tool changer that has a qualifying capacity, in terms of torque, of 1580Nm, over than the 1325Nm of the application.

ROBOTIC TOOLING SOLUTIONS

Tool Changer Docking Station

Destaco offers custom and standard Docking Stations to fit customers needs. Please contact Destaco Sales for more information.

Key Features:

- Allows for quick changing of tooling
- Reducing machine down-time
- Safely stores tooling when not in use
- Standard or custom stations

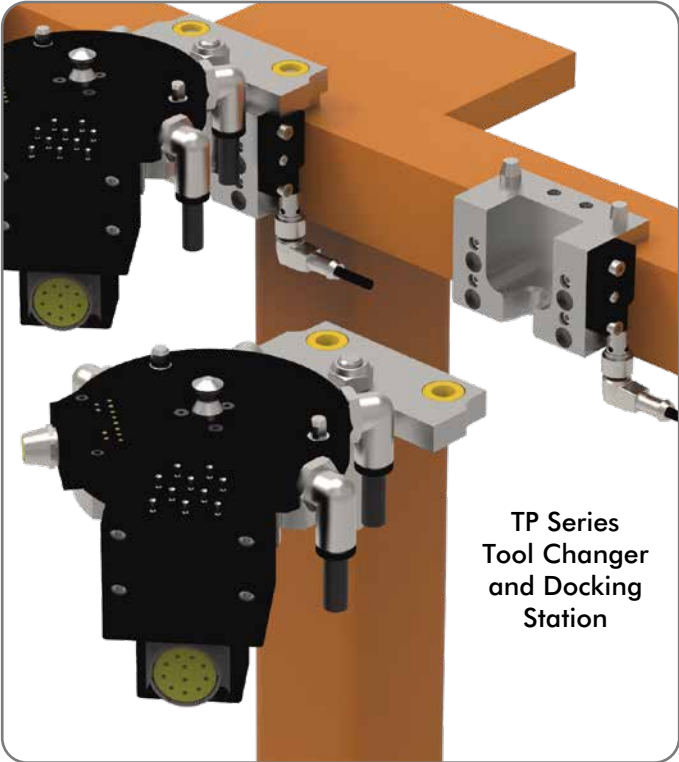
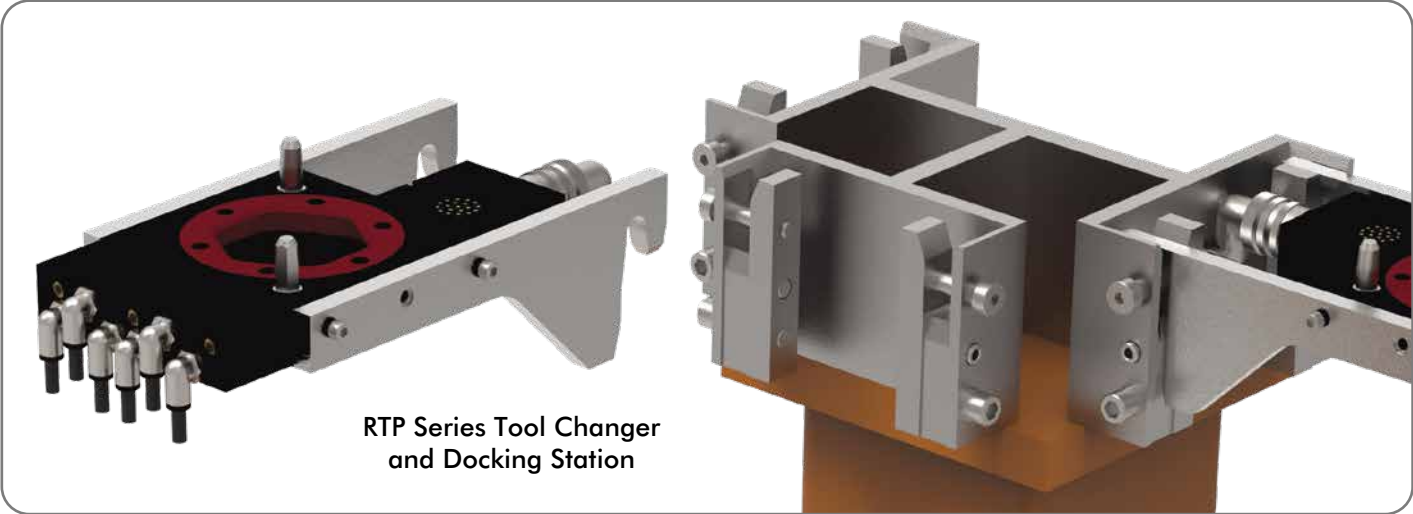

ABOUT DESTACO

Built on a Strong Foundation

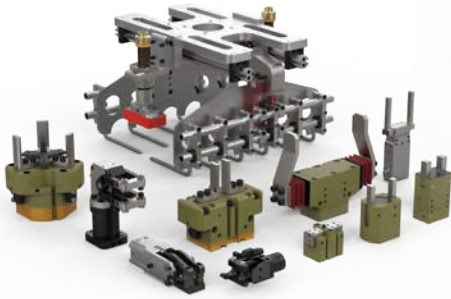

Gripping



Linear Positioning



Rotary Positioning



Clamping



CRL Remote Handling



Robotic Tooling

DESTACO, a Dover company, is a global leader in the design and manufacture of high-performance automation, workholding and remote-handling solutions. The company serves customers in a variety of end-markets, including the automotive, life sciences, consumer packaged goods, aerospace, industrial and nuclear sectors.

Built on a legacy of more than 100 years, DESTACO offers a comprehensive portfolio of products designed to engineer precise movement, placement and control solutions that drive productivity and uptime for manufacturers around the world. The DESTACO family of products consists of industry-leading brands such as DESTACO Manual Clamps, Power Clamps, and End Effectors; CAMCO™ and Ferguson™ Indexers; Robohand™ Grippers; and CRL™ Manipulators and Transfer Ports.

DESTACO is based in Auburn Hills, Michigan, U.S.A. The company has more than 800 employees with 13 locations, in 9 countries, across the Americas, Europe and Asia.

DESTACO is part of Dover Corporation, a diversified global manufacturer with annual revenues of \$7 billion. The company delivers innovative equipment and components, specialty systems and support services through four major operating segments: Energy, Engineered Systems, Fluids, and Refrigeration & Food Equipment. Headquartered in Downers Grove, IL, (NYSE: DOV)

More information is available at destaco.com and dovercorporation.com

Focusing all our Resources

New Product Development

DESTACO has dedicated resources to design and build the next generation of products and solutions

Customer Service and Technical Support

DESTACO has industry leading global support to address any product and application concerns you may have

Design Tools

DESTACO provides an extensive CAD library, sizing software, and online tools to support our global customers



Our Insight Working for You

Application Engineering

We utilize our expertise and complete portfolio of products to create solutions that fit our customers' needs and applications

Custom Solutions

If our off-the-shelf solutions don't fit, we will partner with our customers to develop products that will



Manual and Pneumatic Toggle Clamps and Swing Clamps

Designed to Hold Securely

Markets



Applications



Pneumatic Power Clamps

Clamp with Confidence

Markets



Applications















MANUAL CLAMPING SOLUTIONS

CLICK OR SCAN
To build & download
your own catalog on
these products.



Table of Contents

	Vertical Hold Down Clamps	MC-VHD
	Horizontal Hold Down Clamps	MC-HHD
	Straight Line Action Clamps.....	MC-SLA
	Variable Stroke Straight Line Action Clamps.....	MC-VSC
	Pull Action Latch Clamps	MC-PAL
	Squeeze Action Plier Clamps	MC-SAP
	Accessories	MC-ACC
	Pneumatic Toggle Clamps.....	MC-PTC
	Pneumatic Swing Clamps	MC-PSC
	Pneumatic Power Cylinders.....	MC-PPC
	Hydraulic Clamping Technology.....	MC-HYD
	Pneumatic Power Clamps	PC-PPC

MAKING OUR PRODUCTS SPECIAL FOR YOU

When an off-the-shelf product can't handle it - we can!

With many years of experience working with OEM machine builders, we can make our product fit your unique application. We will partner with you to design the right product for your application – from altering an existing product to building a completely new product, we have the experience and expertise to help your project succeed.

Using our expertise to develop custom solutions for unique applications, DESTACO helps you save time and resources, allowing you to focus on your core business and gain a competitive advantage in the marketplace.

- Proven quality from the experts
- Reduce risk by using our experienced engineers
- Easy reordering with unique part numbers
- Simplify your supply chain
- Three levels of customization from simple alterations to complex custom products

Model 330
Standard Product



330-201 Stainless steel clamp with special hook and locking tab

Model 2002-U
Standard Product

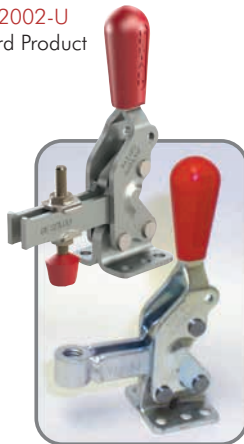

2002-200 with bar cut & bolt retainer welded on

Model 604
Standard Product

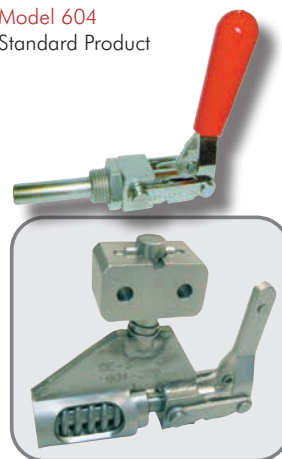

604-229 Stainless steel straight line clamp used in chemical machining process

Model 624/624-MM
Standard Product



624-MM-872 with modified handle and square plunger

Model 202
Standard Product

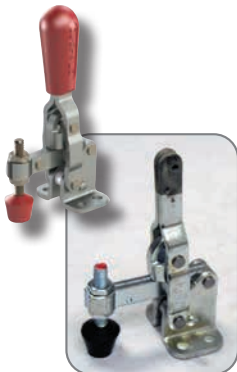

202-200 without grip, with imperial threaded spindle

Model 630-M
Standard Product



630-38 with electroless nickel plating

Model 802-U
Standard Product

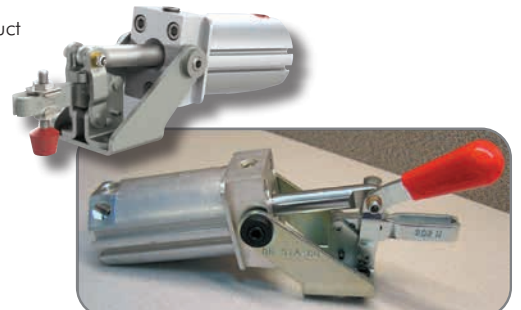

802-U219 with handle for manual operation

MANUAL CLAMPING CUSTOM SOLUTIONS

Custom Solutions for Manual Clamps

Below are some examples of standard products modified to customer specified custom solutions. If there is no product that fits your needs, we will partner with your to design a product that fits.

Model 330
Standard Product

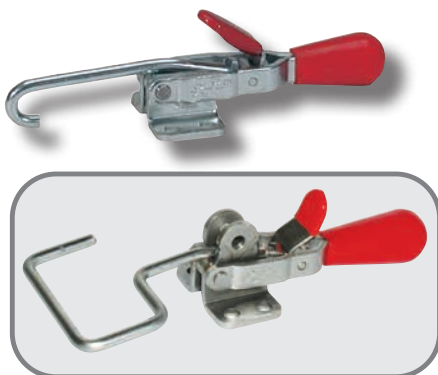

330-201 Stainless steel clamp with special hook and locking tab

Model 2002-U
Standard Product



2002-200 with bar cut and bolt retainer welded on

Model 604
Standard Product

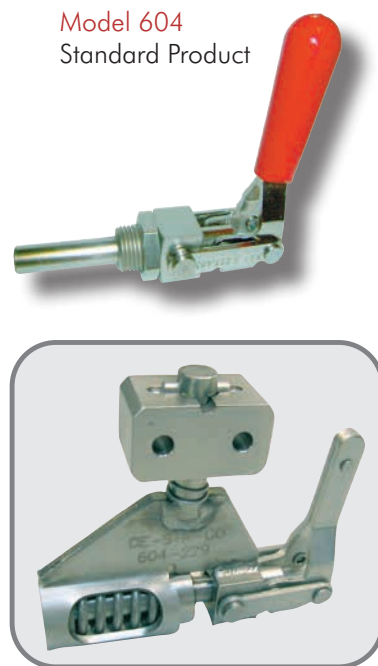

604-229 Stainless steel straight line clamp used in chemical machining process

Contact us today to get started on your custom application: clamps@destaco.com

Markets



Industrial



Aerospace



Food & Packaging



Transportation



Consumer Goods

Applications



Assembly



Welding



Fixture and Testing



CNC/Machining



White Goods/
Appliance



Woodworking

MAKING OUR PRODUCTS SPECIAL FOR YOU

Custom Solutions for Manual Clamps

DESTACO offers three levels of modifications for customizing our manual clamping products to fit our customers specified applications. Depending on the severity of the modifications, quoting times may take longer.

Level 1 Modifications:

- Alternate standard accessories
- Removal of grips
- Alternate plating/coating
- Alternate vinyl dipping
- Quotes within 1 day*

Model 202
Standard Product

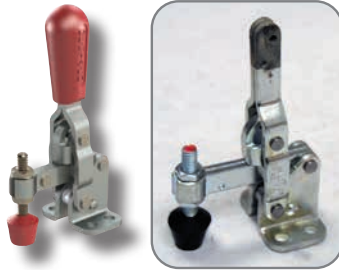

202-200 without grip,
with imperial threaded
spindle

Model 630-M
Standard Product

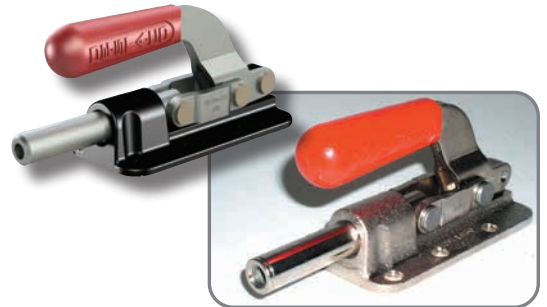

630-38 with electroless nickel plating

Level 2 Modifications:

- Handle and arm extensions
- Custom hooks for pull-action clamps
- Cut-off handles and arms
- Drilled & tapped arms
- Quotes within 3 days*

Model 2002-U
Standard Product

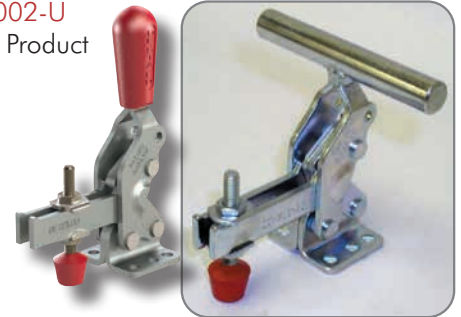

2002-201 with special T-handle

Level 3 Modifications:

- Engineered modifications
- Special plungers for straight line action clamps
- Quotes within 5 days*

Model 624/624-MM
Standard Product



624-MM-872 with modified handle and
square plunger

Model 802-U
Standard Product



802-U219 with handle for manual operation

(* All inquiries subject to minimum order

COLOR HANDLES FOR MANUAL CLAMPS

For visible assignment to security levels, operating modes or maintenance intervals

DESTACO is expanding the selection of color manual clamp handles. Different families of manual clamps are now available with 5 handle colors. The range of colors is interesting for customers who work in prototype construction as well as for customers who need to implement specific safety aspects using standardized color codes. Also it provides the option to have a customized color design.

- Manual lever handles in 5 different colors
- Can be ordered on any manual clamp series that uses DESTACO's standard ergonomic handle



The series/models listed below are our most popular models that can be ordered with color handles*. Add -Y, -G, -B, -K at end of model number.

*Excludes Blackout Series, Toggle Lock Plus levers or dipped handles.



Popular Models	Standard Red Handle	Green	Blue	Yellow	Black
202	202-U	202-U-G	202-U-B	202-U-Y	202-U-K
207	207-U	207-U-G	207-U-B	207-U-Y	207-U-K
602	602-MM	602-MM-G	602-MM-B	602-MM-Y	602-MM-K
604	604-MM	604-MM-G	604-MM-B	604-MM-Y	604-MM-K
624	624-MM	624-MM-G	624-MM-B	624-MM-Y	624-MM-K
213	213-USS	213-USS-G	213-USS-B	213-USS-Y	213-USS-K
227	227-U	227-U-G	227-U-B	227-U-Y	227-U-K
237	237-U	237-U-G	237-U-B	237-U-Y	237-U-K
2002	2002-U	2002-U-G	2002-U-B	2002-U-Y	2002-U-K
2007	2007-U	2007-U-G	2007-U-B	2007-U-Y	2007-U-K
2010	2010-U	2010-U-G	2010-U-B	2010-U-Y	2010-U-K
2013	2013-U	2013-U-G	2013-U-B	2013-U-Y	2013-U-K
2017	2017-U	2017-U-G	2017-U-B	2017-U-Y	2017-U-K
2027	2027-U	2027-U-G	2027-U-B	2027-U-Y	2027-U-K

STAINLESS STEEL CLAMPING SOLUTIONS

For Vertical, Horizontal, Pull-action Latch and Straight Line-Action Toggle Clamps

DESTACO's stainless steel product offering includes 60 models of vertical, horizontal, pull-action latch and straight line-action toggle clamps. They are, fabricated with corrosion, chemical and heat resistant stainless steel.











These stainless steel clamps are suitable for many applications that demand a clamp that is more robust than traditional steel models and are well-suited for outdoor use and food processing, as well as plating, finishing, chemical handling, pharmaceutical manufacturing and other high-temperature or harsh environments. They offer greater capabilities in a cost-effective package.



Product Highlights/Options

- Full stainless steel construction
- Corrosion and heat resistant
- Stainless steel, spindles, hooks and latch plates
- 60 models

Features, Markets and Applications

 <p>PERFORMANCE</p>	<ul style="list-style-type: none"> • Heat resisting non-magnetic stainless steel in the annealed state and slightly magnetic when cold worked • Stainless steel clamp and rivet design for withstanding corrosive or high temperature (>250° F) applications 	 <p>FOOD & PACKAGING</p>	 <p>ASSEMBLY</p>
 <p>INTERCHANGEABLE</p>	<ul style="list-style-type: none"> • Standard mounting pattern for interchangeability with exist equipment • Oil resistant vinyl or PVC handles can be removed for high temperature applications 	 <p>CONSUMER GOODS</p>	 <p>FIXTURE/TESTING</p>
 <p>SAFETY</p>	<ul style="list-style-type: none"> • Clamp can be locked in open and closed position with optional DESTACO® Toggle Lock Plus™ • Ergonomic and Safe operation 	 <p>INDUSTRIAL</p>	 <p>MOLDING</p>
		 <p>LIFE SCIENCES</p>	 <p>WELDING</p>

ABOUT DESTACO

Built on a Strong Foundation

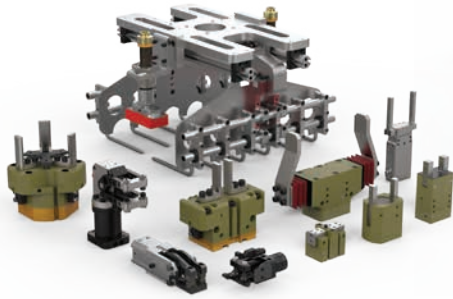

Gripping Solutions



Linear Positioning Solutions

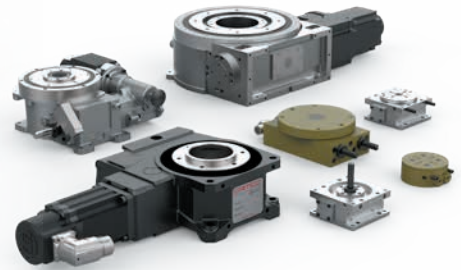

Rotary Positioning Solutions

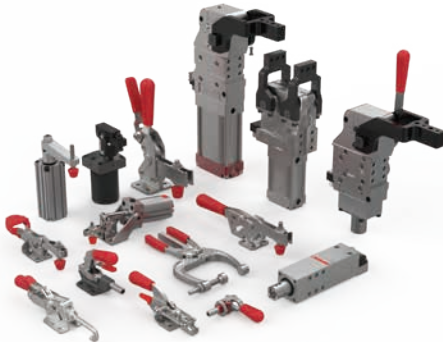

Clamping Solutions



CRL Remote Handling Solutions



Robotic Tooling Solutions

Destaco, a Dover company, is a global leader in the design and manufacture of high-performance automation, workholding and remote-handling solutions. The company serves customers in a variety of end-markets, including the automotive, life sciences, consumer packaged goods, aerospace, industrial and nuclear sectors.

Built on a legacy of more than 100 years, Destaco offers a comprehensive portfolio of products designed to engineer precise movement, placement and control solutions that drive productivity and uptime for manufacturers around the world. The Destaco family of products consists of industry-leading brands such as Destaco Manual Clamps, Power Clamps, and End Effectors; CAMCO™ and Ferguson™ Indexers; Robohand™ Grippers; and CRL™ Manipulators and Transfer Ports.

Destaco is based in Auburn Hills, Michigan, U.S.A. The company has more than 800 employees with 13 locations, in 9 countries, across the Americas, Europe and Asia.

Destaco is part of Dover Corporation, a diversified global manufacturer with annual revenues of \$7 billion. The company delivers innovative equipment and components, specialty systems and support services through four major operating segments: Energy, Engineered Systems, Fluids, and Refrigeration & Food Equipment. Headquartered in Downers Grove, IL, (NYSE: DOV)

More information is available at destaco.com and dovercorporation.com

Focusing all our Resources

New Product Development

Destaco has dedicated resources to design and build the next generation of products and solutions

Customer Service and Technical Support

Destaco has industry leading global support to address any product and application concerns you may have

Design Tools

Destaco provides an extensive CAD library, sizing software, and online tools to support our global customers



Our Insight Working for You

Application Engineering

We utilize our expertise and complete portfolio of products to create solutions that fit our customers' needs and applications



Pneumatic & Electric Power Clamps, Pin Clamps/Packages, and Pivot Units

Clamp with Confidence

Markets



Transportation



Aerospace



Food & Packaging



Industrial



Consumer Goods

Applications



Assembly



Welding



Fixture and Testing



White Goods/
Appliance



CNC/Machining



Electric Products



Pneumatic Power Clamps

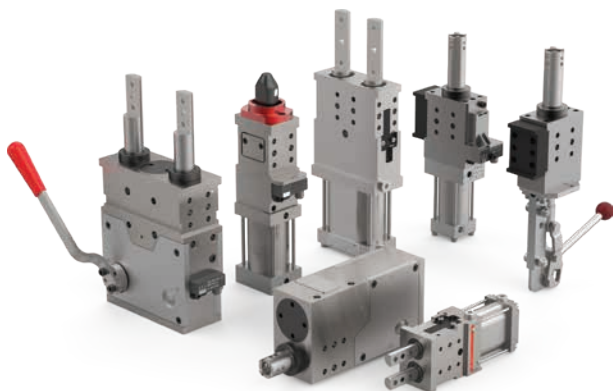

Pneumatic Pin Clamps and Packages



Pneumatic Pivot Units



Body-in-White EcoSmart Solutions

PNEUMATIC CLAMPING SOLUTIONS

Table of Contents



EcoSmart Electric ProductsPC-ELC



Pneumatic Power Clamps PC-PPC



Pin Clamps.....PC-HPC



Precision Guides..... PC-PGL



Pin PackagesPC-PKG



Pivot Units.....PC-PVT

FEATURED NEW PRODUCTS

82L-3E /82M-3E Power Clamps

Adjustable Light and Heavy-weight Enclosed Power Clamps

- Field adjustable arm opening angle
- Enclosed aluminum body
- Optional U-Arms and lateral arms available

See Pages PC-PPC-13 & 33

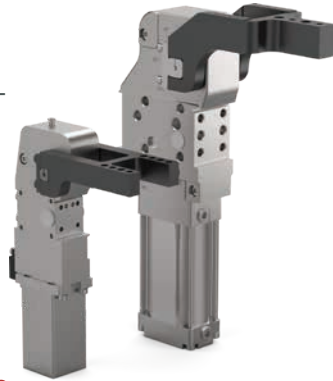

Body-in-White EcoSmart Solutions

Evolution in Productivity

- Complete Body-in-White Product Portfolio
- Smart & Economy Line
- Plug & Play solution - fast start up
- Integrated position & hold down control

See Page PC-ELC-1

EcoSmart

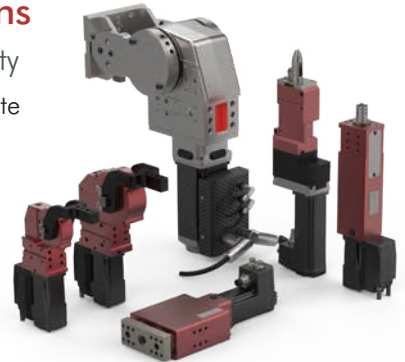

TCC Series

Tolerance Compensation Heavyweight Enclosed Power Clamps

- Tolerance compensation
- Field adjustable arm opening angle
- Enclosed aluminum body
- Optional U-Arms and lateral arms available

See Pages PC-PPC-29



84A40/50 Series

Dual-Arm Tolerance Compensation Clamps

- Tolerance compensation
- 90° clamp arm motion
- Multiple clamp arm options
- High clamping force, compact size
- Enclosed aluminum body

See Page PC-PPC-83



85P50-1800 Series

Tolerance Compensation Centering Pin Clamp

- Tolerance compensation
- Self-locking mechanism in clamping position
- Variety of pins and hook sizes
- Integrated sensing
- Enclosed aluminum body

See Pages PC-HPC-19



86P30-5 Series

Single Pin Packages

- Available with 20 mm or 40 mm strokes
- Compact design with lateral and front-face mounting areas
- Enclosed aluminum body

See Page PC-PKG-1



RCM/RFM Series

Pneumatic Pivot Units

- Field adjustable opening angle
- Integrated (SBI) Lock System (RFM Series)
- Fixed inductive sensor
- Four cylinder bore sizes, one cylinder length
- Pneumo-hydraulic motion control

See Page PC-PVT-1



85D5-2 Series

Double Pin Package

- Optional hand lever for manual control
- Compact design with lateral and front-face mounting areas
- Sensors can be mounted on either side of unit
- Flexible hand lever mounting positions

See Pages PC-PKG-29





THE BEST PRODUCTS.
UNMATCHED SERVICE.
WORLDWIDE.

GLOBAL SALES CONTACTS

CORPORATE HEADQUARTERS



US
+1-888-DESTACO
+1-248-836-6700
northamerica@destaco.com



DE
+49-6171-705-0
europe@destaco.com



SP
+34-936361680
spain@destaco.com



PL
+48-506002115
poland@destaco.com



IN
+91-80-41123421-426
india@destaco.com



MX
mexico@destaco.com



FR
+33-4-7354-5001
france@destaco.com



CN
+86-21-6081-2888
china@destaco.com



NL
+31-297285332
benelux@destaco.com



SG
singapore@destaco.com



UK
+44-1902-797980
uk@destaco.com



TH
+66-2-326-0812
asia@destaco.com



CZ
+420-603-577-341
czech@destaco.com



CA
canada@destaco.com