

# 6015 SERIES

## Straight Line Action Clamps | Product Overview

### Features:

- Smallest of the solid base Straight Line Action clamps
- Compact design combined with high holding capacity
- Allow handle to fall below mounting plane to lock in retracted position

### Applications:

- Assembly
- Checking fixtures
- Tensioning devices

### Also Available:

See page MC-ACC-1 for accessories

Covered under one or more U.S./International Patents

6015  
6015-M



6015-SS,  
6015-MSS  
Stainless  
Steel



6015-R,  
6015-MR  
with DESTACO®  
Toggle Lock  
Plus

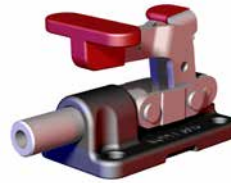

## Technical Information | Holding Capacities

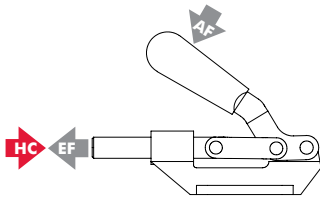

Model	Max. Holding Capacity	Weight	EF:AF (pushing/pulling)	Plunger Travel	(M) Plunger Thread	Recommended Spindle (Not Supplied)
6015	[560 lbf] 2500 N				1/4-20	205203
6015-M					M6	205203-M
6015-SS	[630 lbf] 2800 N	[0.35lb] 0,15kg	35:1	[0.70] 17,8	1/4-20	202943 (supplied)
6015-MSS					M6	202916-M (supplied)
6015-R	[560 lbf] 2500 N				1/4-20	205203
6015-MR					M6	205203-M

HC = Holding Capacity, EF = Exerting Force, AF = Applied Force

# 6015 SERIES

## Straight Line Action Clamps | Dimensions | -M/-SS/-MSS/-R/-MR

6015  
6015-M



6015-SS,  
6015-MSS  
Stainless  
Steel



6015-R,  
6015-MR  
with DESTACO®  
Toggle Lock Plus

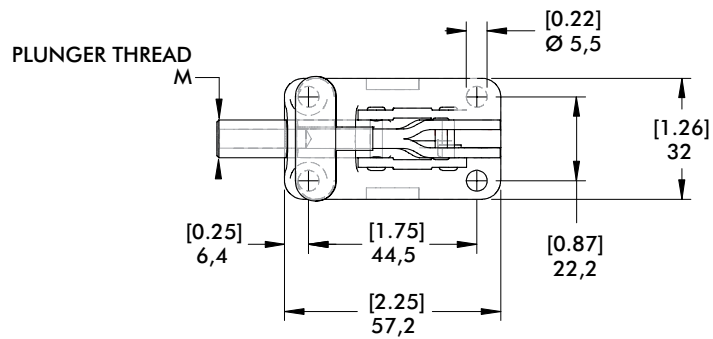

DESTACO®  
TOGGLE LOCK  
PLUS OPTION  
6015-R / 6015-MR  
(Engages in extended  
position only)

